



GÉANT Status update

Enzo Capone
Head of Research Engagement and Support

LHCOPN-ONE Meeting @ HEPIX2023 – Victoria (CA)

18th October 2023

Packet Layer Renewal

3 years project started early 2022

400G availability throughout the whole GÉANT footprint

Highspeed network availability to the edges of Europe

Enabling global partners to connect at or close to landing stations

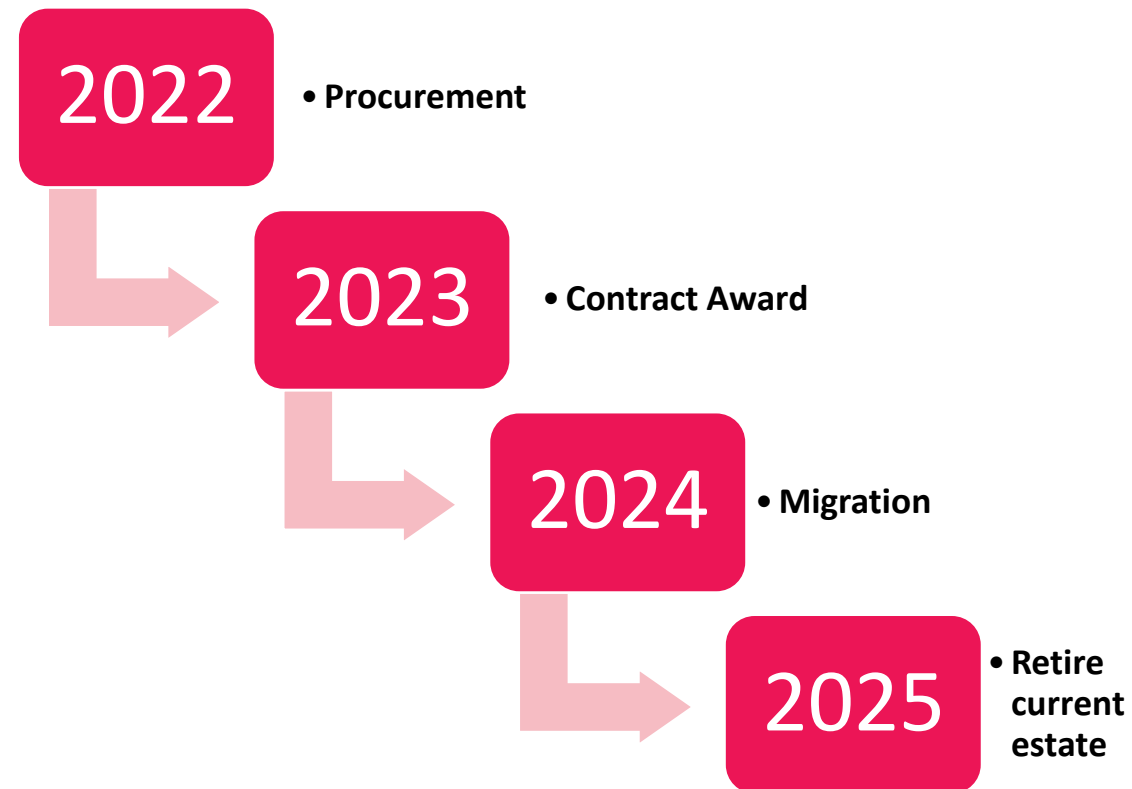

Enter the new platform

NOKIA



7750 SR-7s



7750 SR-2se Compact

Hardware

- 36 ports
- 800/400/100/10 Gbps
- Max 12 Tbps switch fabric speed
- Possibility to combine different port speeds via breakout module

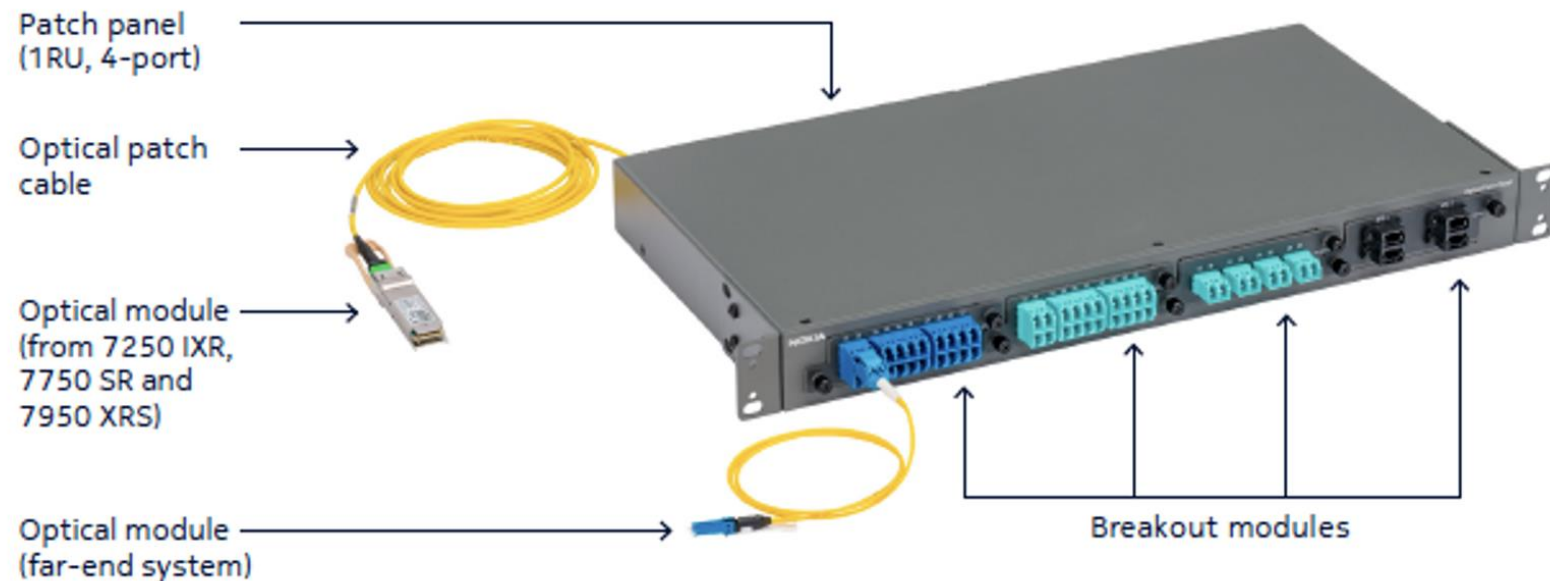
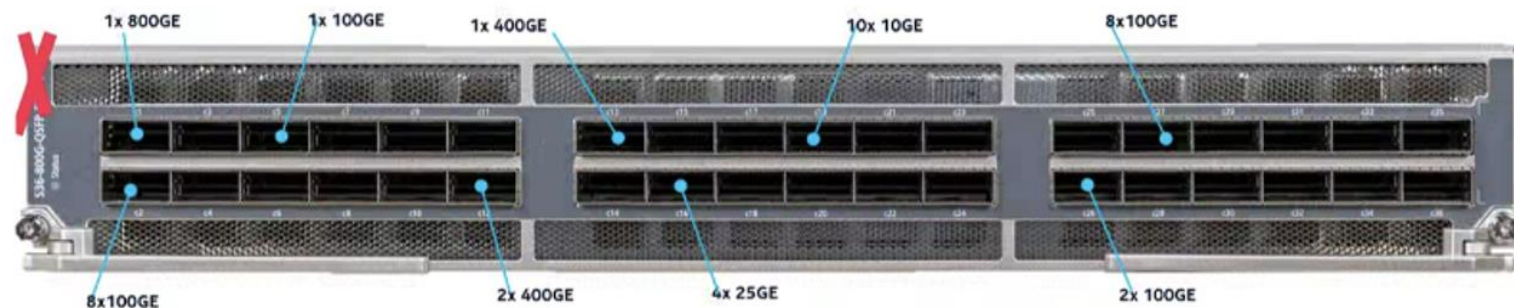

Functionalities

- IS-IS
- RSVP-TE (for bandwidth reservation)
- iBGP and Multiprotocol BGP
- PIM (for Multicast)
- Segment routing (SR-MPLS and TI-LFA)
- TWAMP

Services

- IP/MPLS
- L2VPN (tLDP, RSVP-TE, BGP VPLS)
- L3VPN
- ASM and SSM Multicast
- Guaranteed Bandwidth Service

Migration timeline

- Stage 1 (1H-2024)
 - New platform configured as “P” routers (only trunk connection)
 - Old platform configured as “PE” routers (services termination)
 - Functionalities enabled
 - Services to be enabled on a case-by-case basis
- Stage 2 (2H-2024 to 1H-2025)
 - New platform configured as “P/PE”
 - All services enabled and migrated
 - Old platform removed

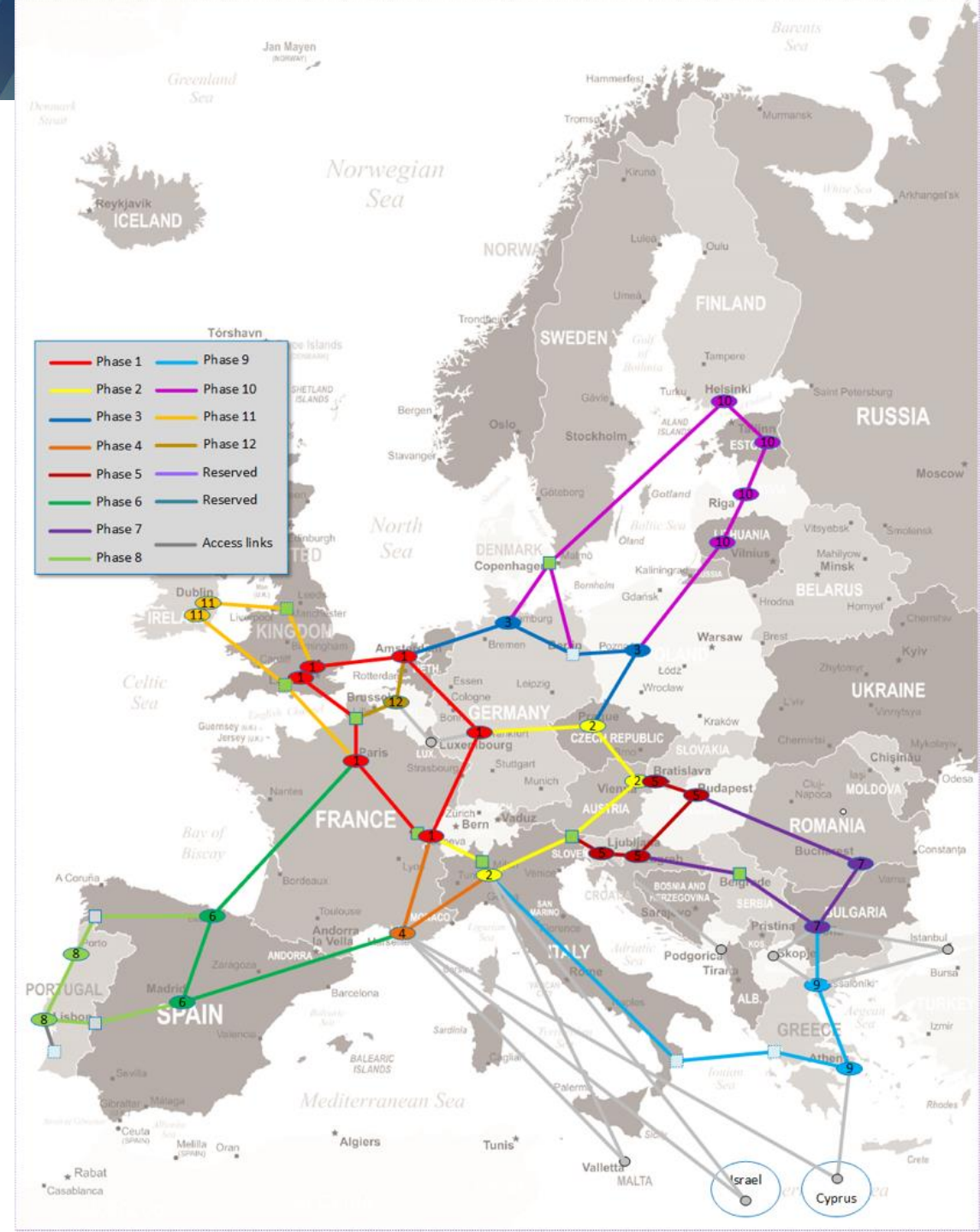

Migration steps

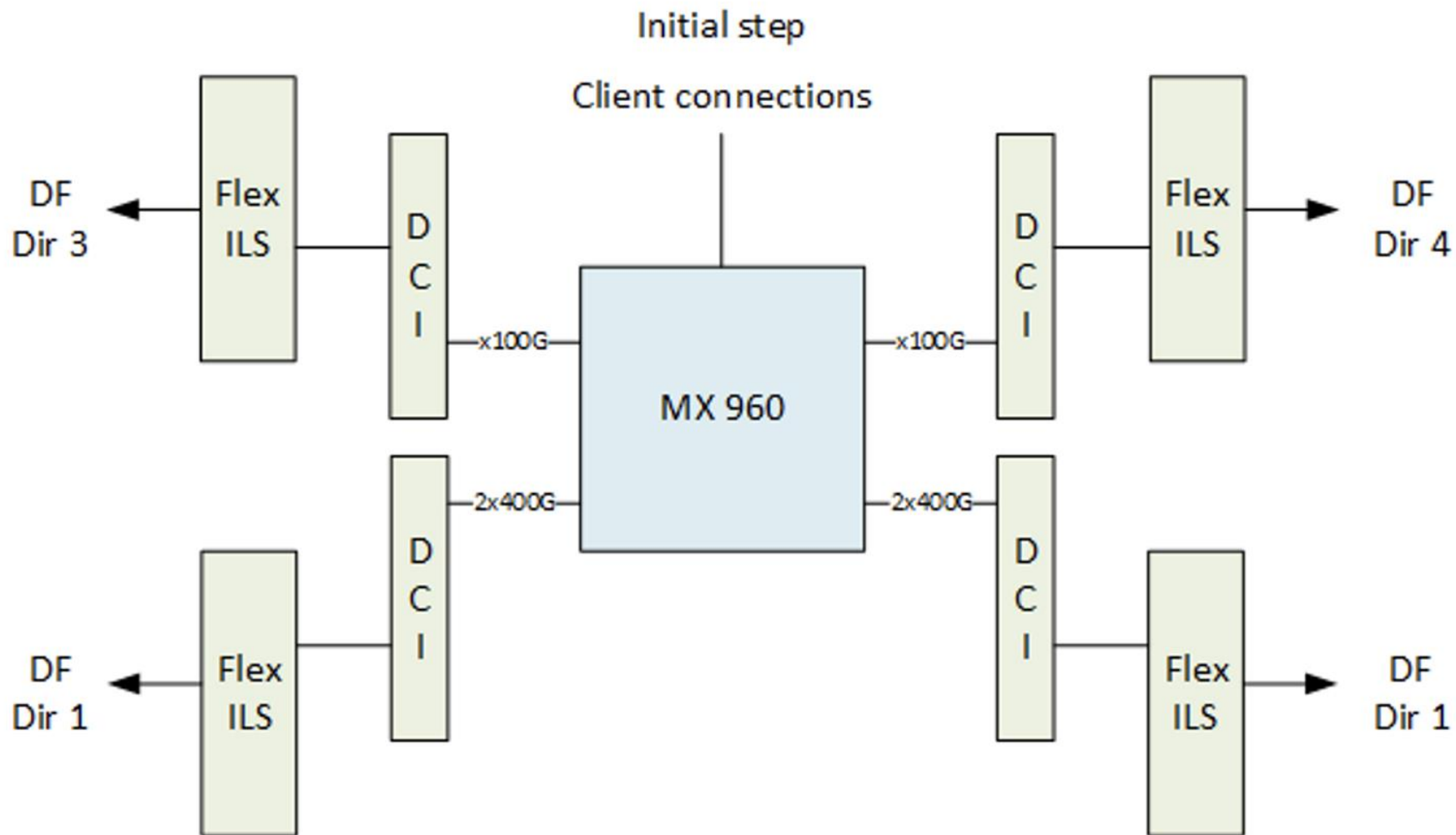

DCI = transmission layer transponder, Flex ILS = transmission layer terminal node, DF Dir = dark fibre

Migration steps

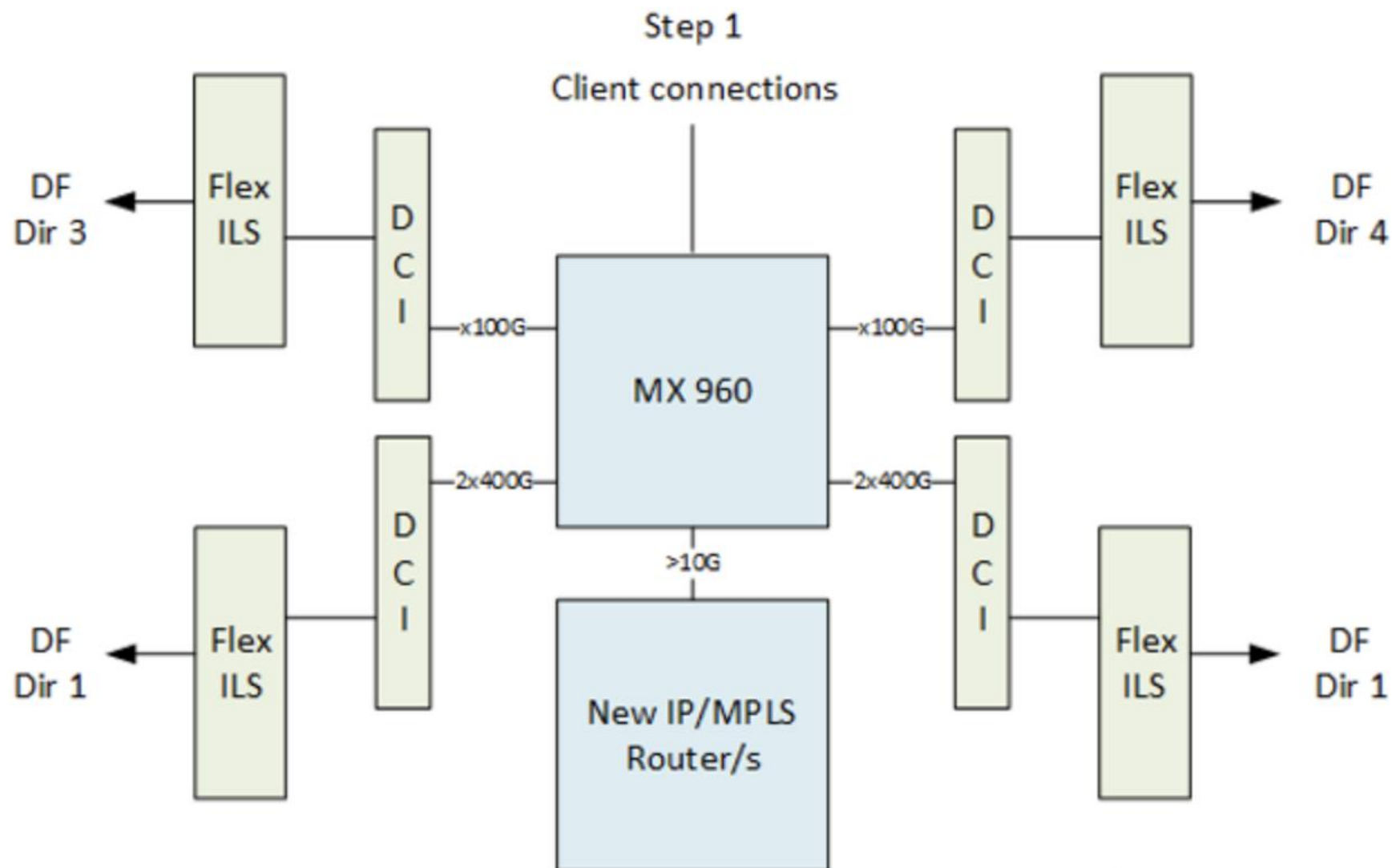

Migration steps

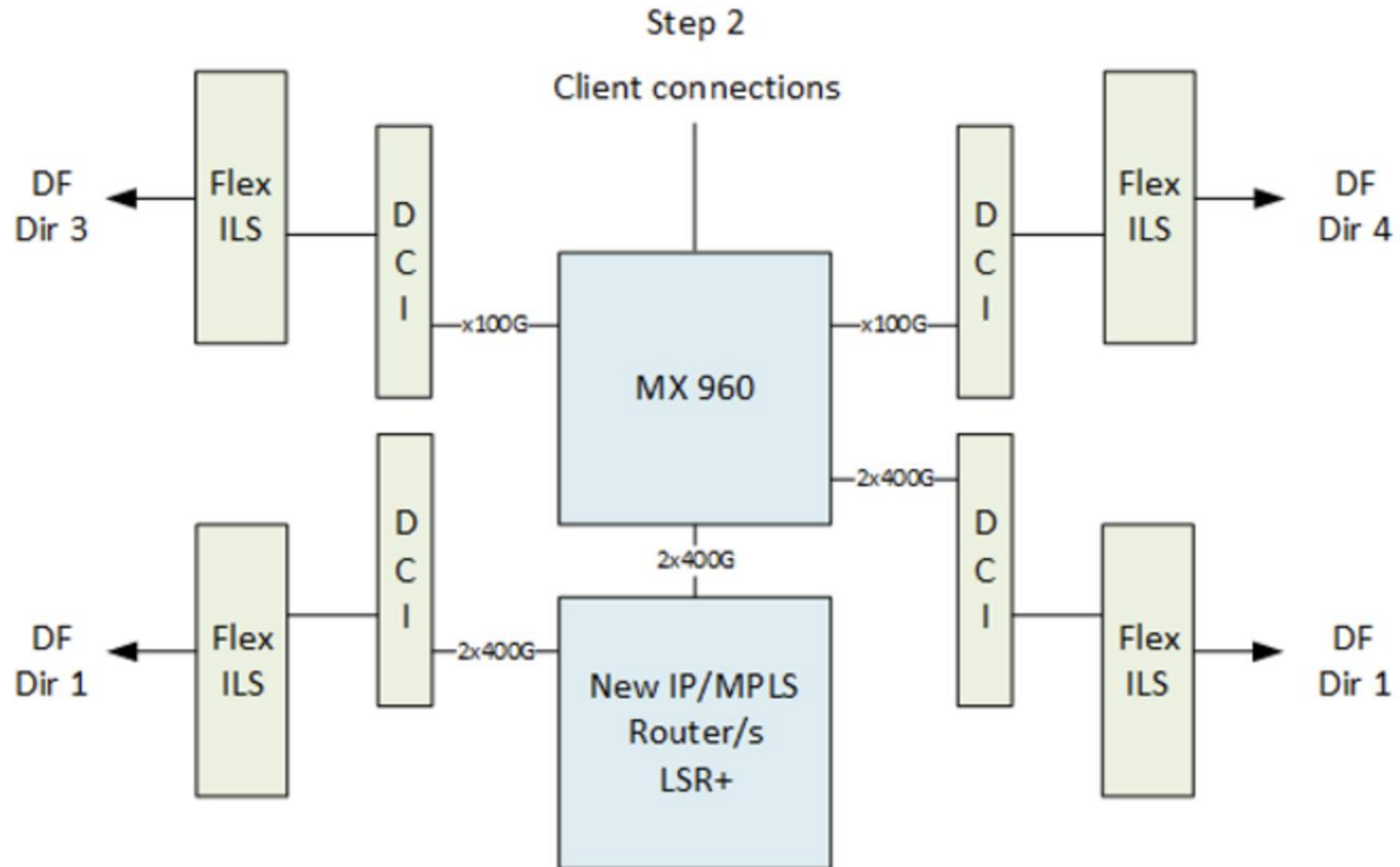

Migration steps

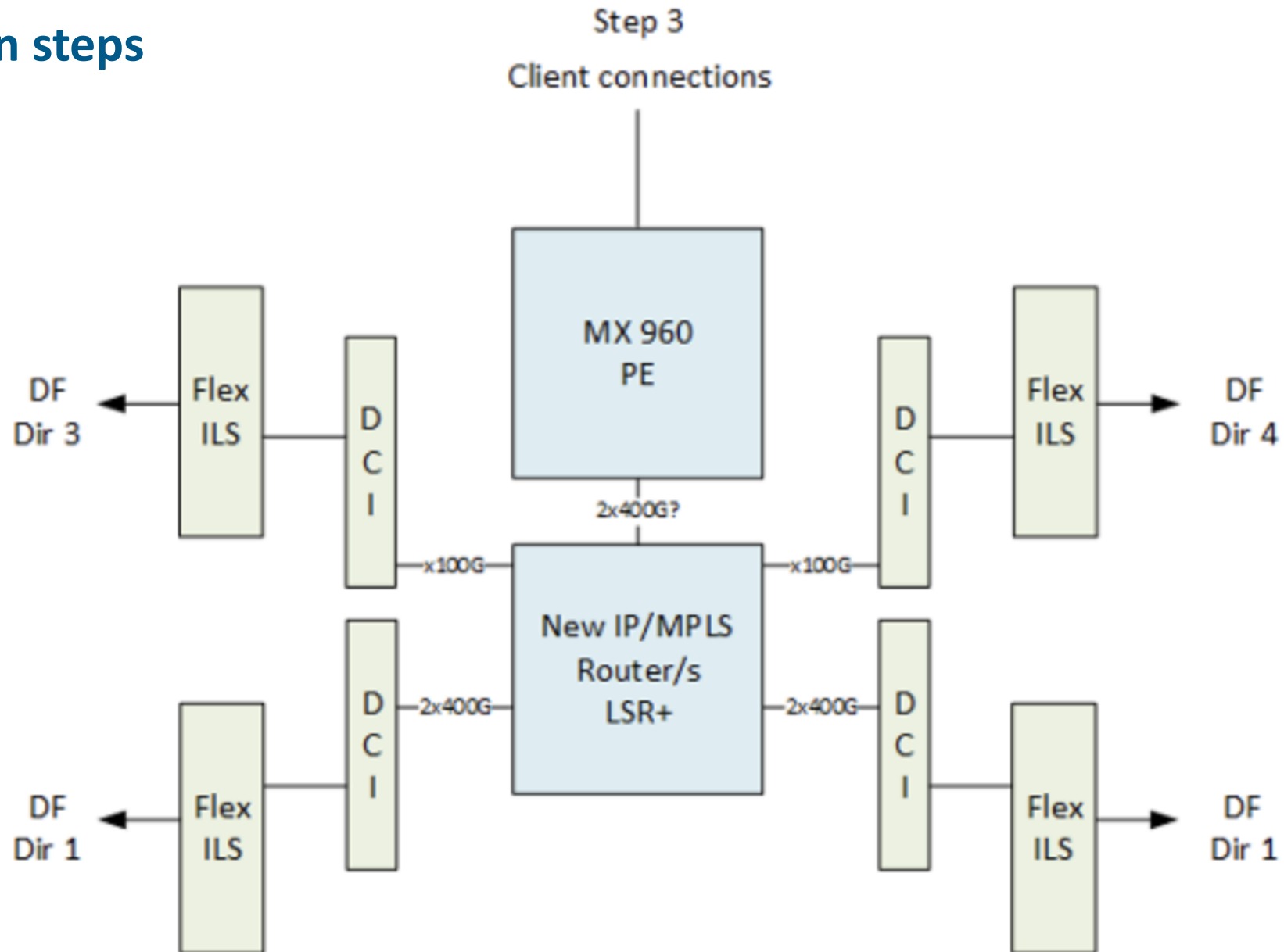

Migration steps

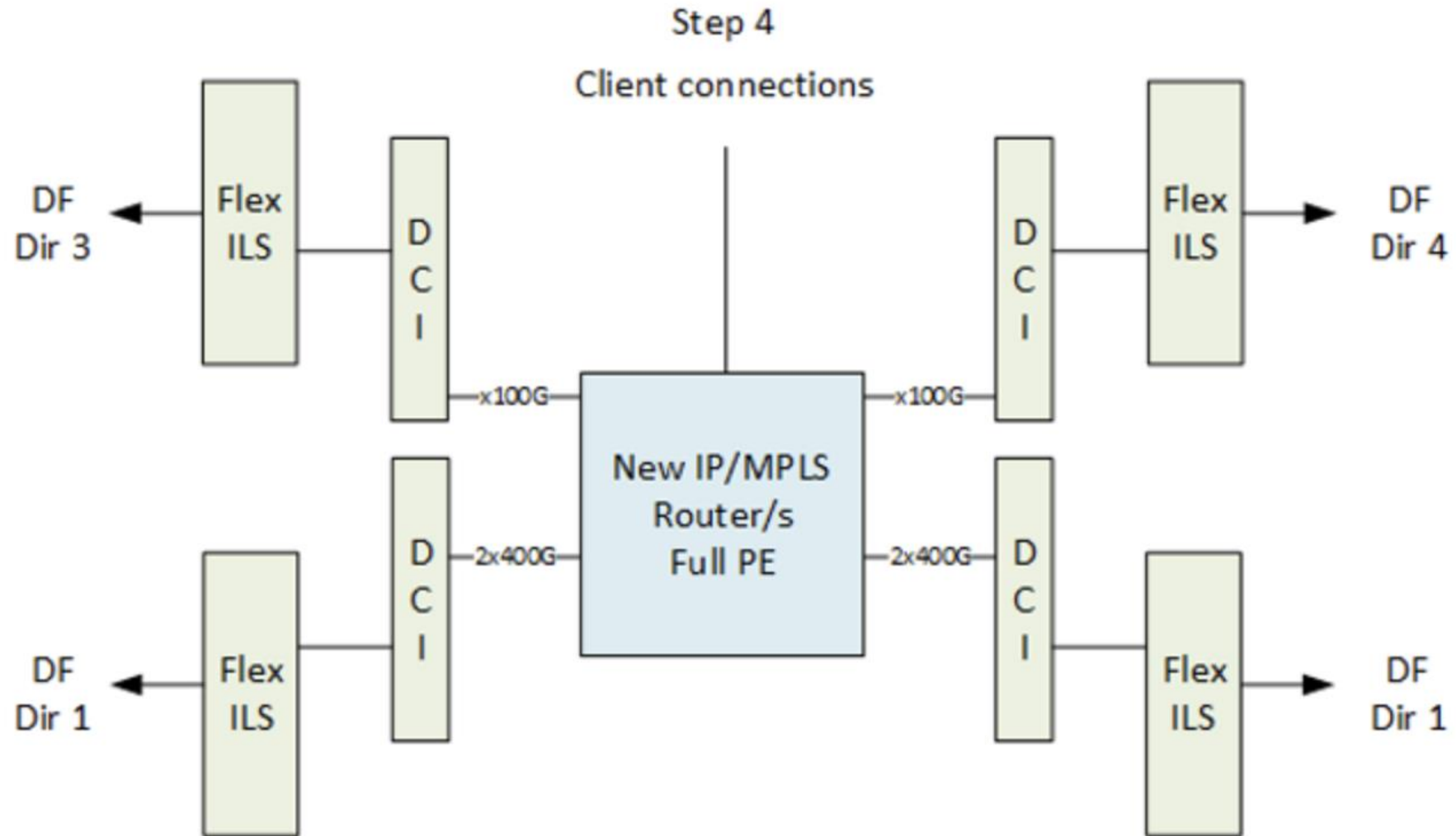

Automation platform (legacy)

The GÉANT automation Platform (GAP) for the current Juniper network is mainly based on Ansible for the inventory, and service mapping to playbooks. Jenkins is used to function as workflow engine. Example workflows are:

- Node provisioning
- IPTrunk provisioning (including functional tests)
- Node OS upgrade (including pre/post checks)
- Node insertion in the network (iBGP/MSDP mesh update)
- Other standard operations (deploy TWAMP probes and similar)

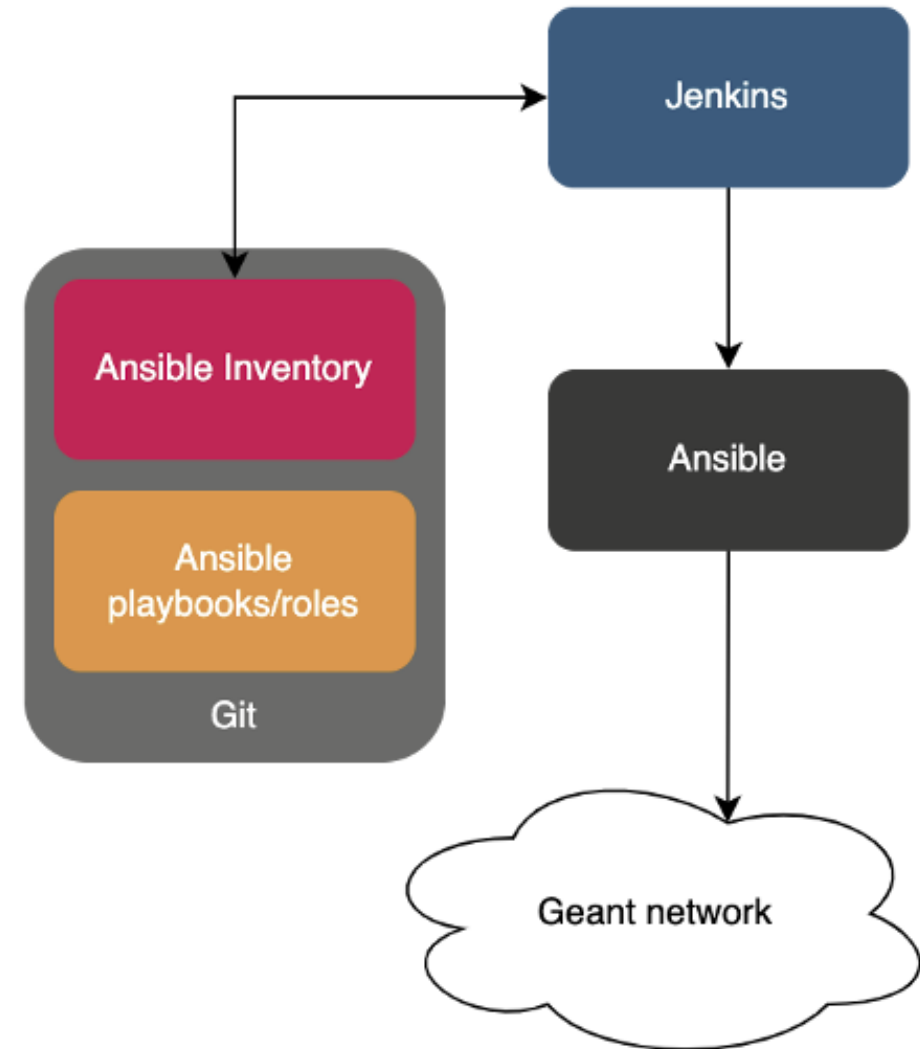

The New Automation platform

One of the major enhancements in the new GAP stack will be the introduction of Workflow orchestrator (WFO)

- Centralized integration
- Multitenancy
- Community-driven (in production at ESnet and SURF)
- LSO (Lightweight Service Orchestrator) is the API towards the Ansible application engine

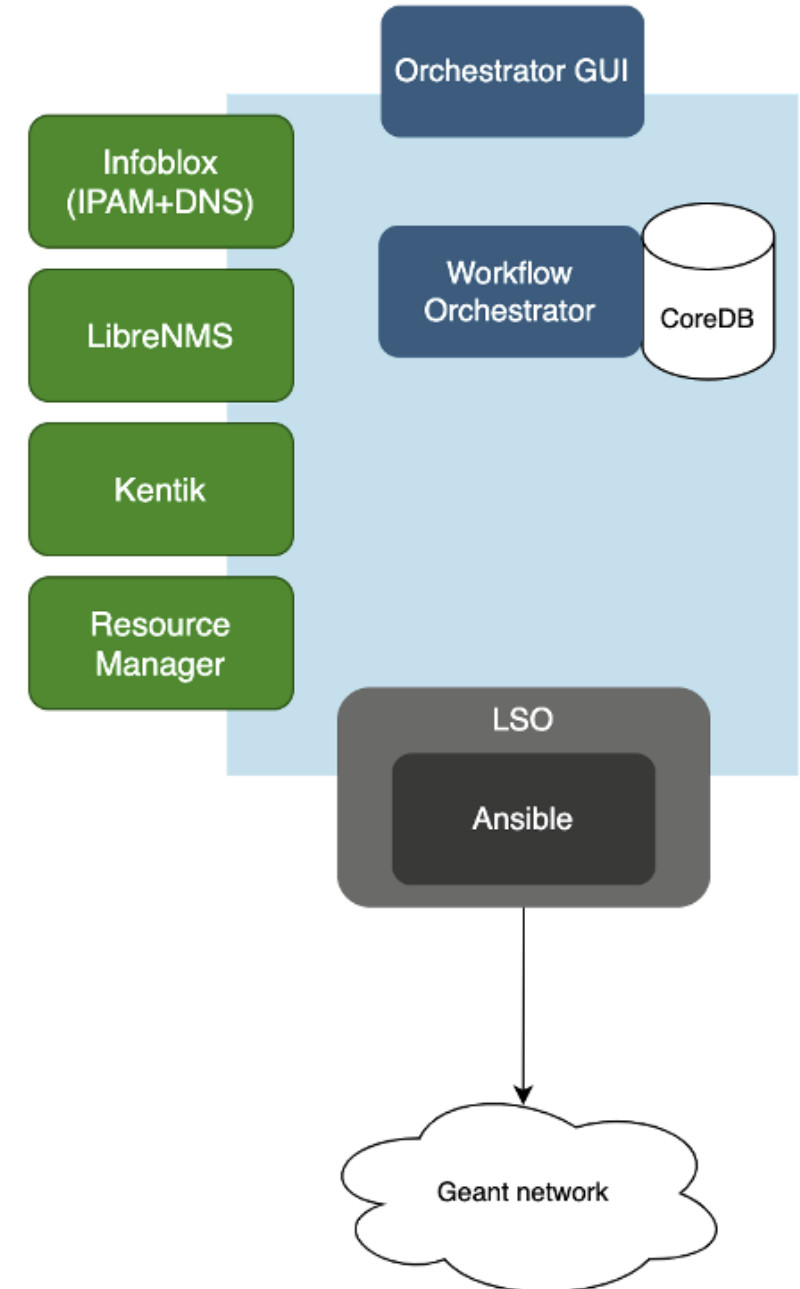

GN5-Intercontinental Connectivity 1 project

Building on the GN4-3N experiences

3 years project starting 1st December 2022

€15M funding (~13M on Connectivity)

Two regions – Southeastern Asia and **North America**

Deliver in collaboration with international partners

Establish **long term Intercontinental** capacity planning and **investment plan**

For **North America** under IC1:

- GÉANT along with partner R&E networks, aim to have **4+ links at terabit** capacity by 2027
- GEANT aim to obtain **~20/30% of a DF link**, across 1, 2 or 3 cable systems





Thank You

Any questions?

vincenzo.capone@geant.org

[@EnzinoCapone](https://twitter.com/EnzinoCapone) 

[@GEANTnews](https://twitter.com/GEANTnews) 

www.geant.org



© GÉANT Association
As part of the GÉANT 2020 Framework Partnership Agreement (FPA), the project receives funding from the European Union's Horizon 2020 research and innovation programme under Grant Agreement No. 856726 (GN4-3).