

TOF ALIGNMENT DATABASE



OUTLINE

- Possible Misalignments
- Strip Alignment
- Supermodule Alignment
- Space Frame Deformations
- Supermodule Fiducial Marks
- Alignment Parameters
- Alignment DB Update/Access Frequency
- Alignment Strategies
- Summary & Conclusions



POSSIBLE MISALIGNMENTS

- The basic TOF elements (modules, strips) can be schematically represented with parallelepipeds.
- Misalignments can generate spatial shifts or tiltings wrt the ideal positions.

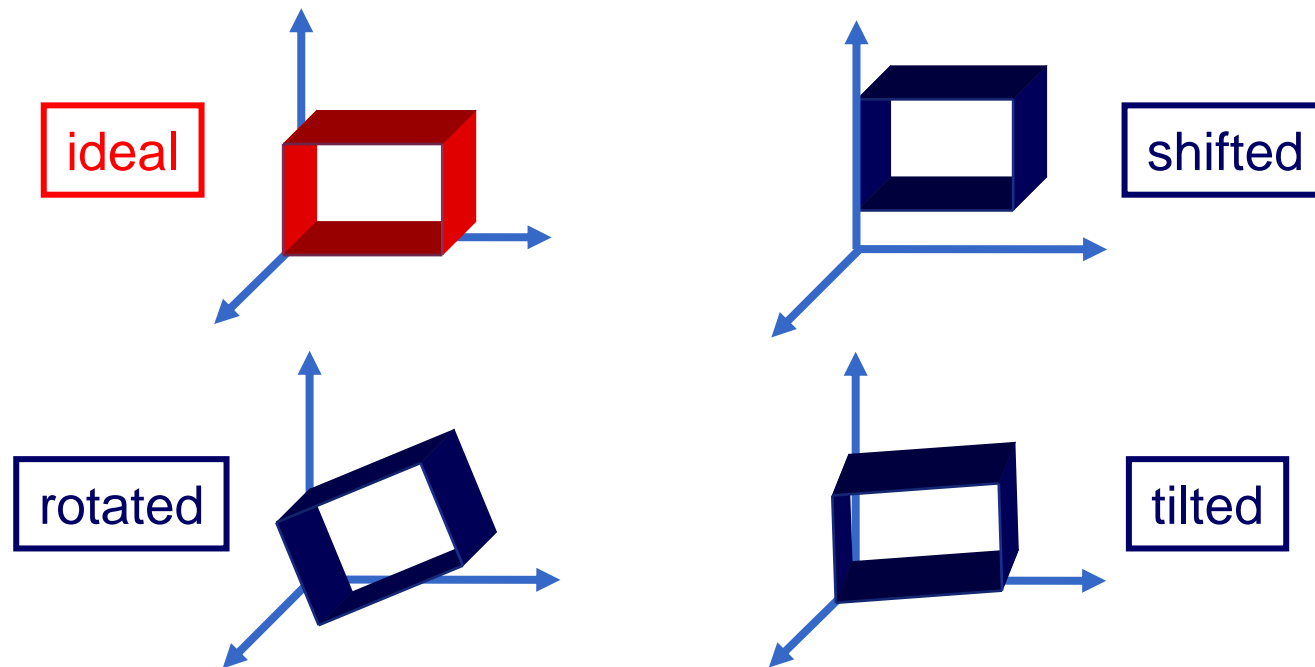



STRIP ALIGNMENT INSIDE THE MODULE

- Inside each module, the strips positions are fixed with four precision screws (with the correspondent holes), two on each side. The tolerance on the screws is $< 1 \text{ mm}$.
- The tolerance on the positions of the screws is expected to be $< \text{mm}$.

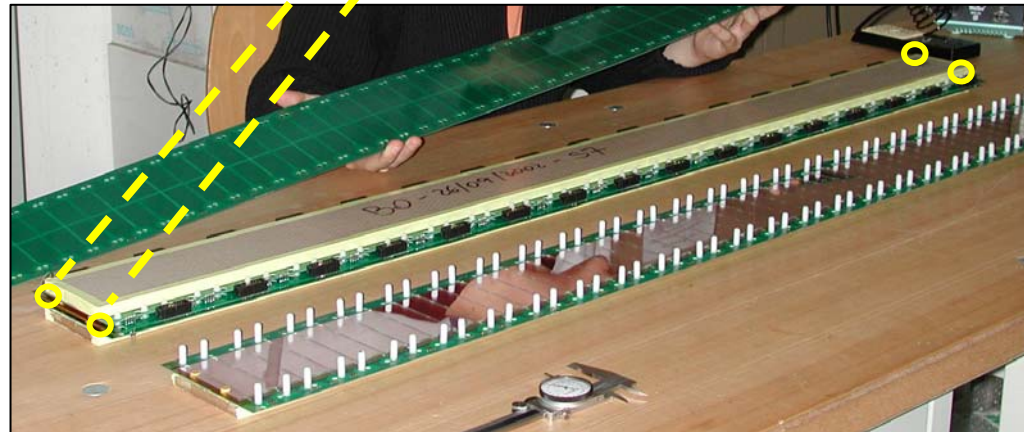
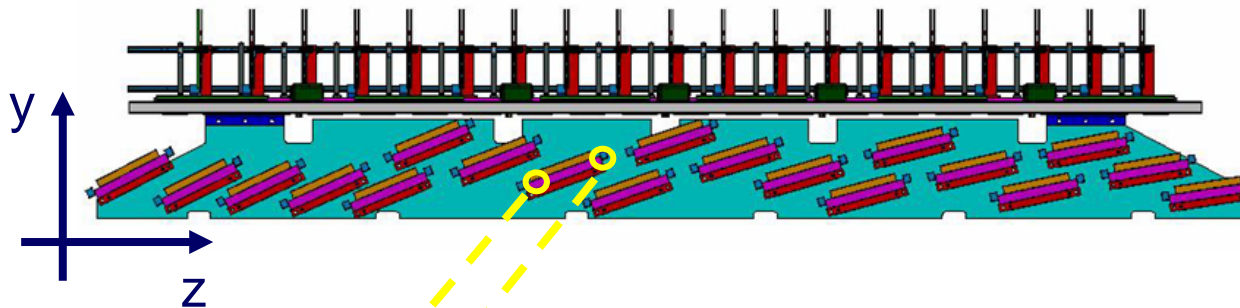



STRIP POSITIONS

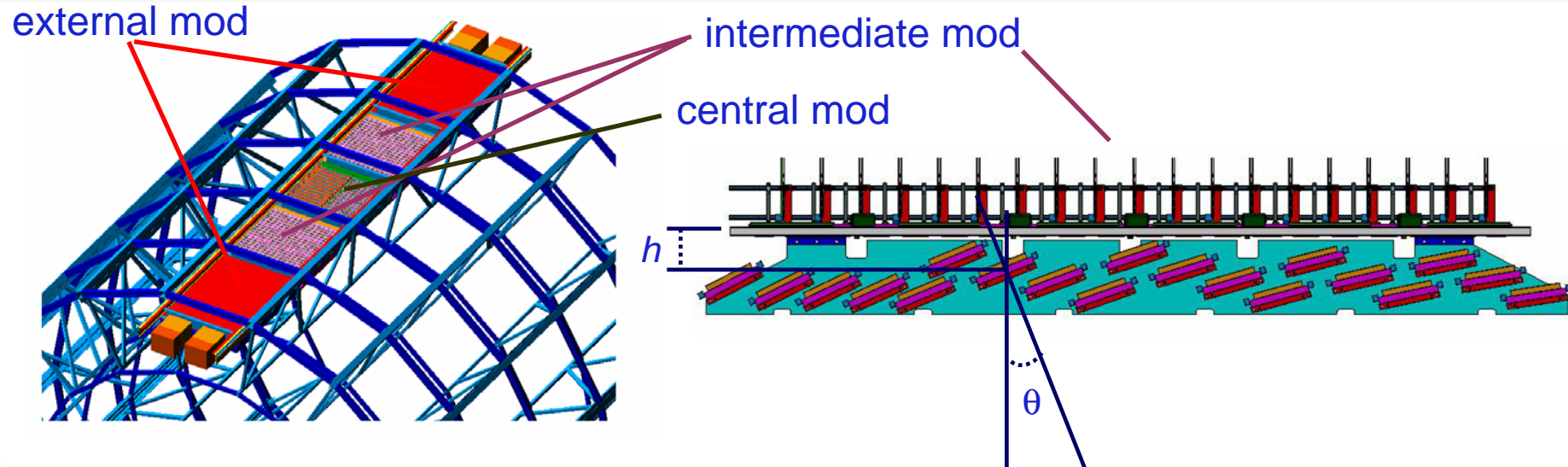

➤ Positioning of the STRIPS inside the modules:

- 2 external mod.: 2×19 strips
- 2 interm. mod.: 2×19 strips
- central mod.: 15 strips
- *two coordinates (h, θ) for each strip*

$$(4 \times 19 + 15) \times 2 \times 18 = 3276$$



MODULE ASSEMBLY

- Each TOF supermodule (18) is made up of five modules (one central, two intermediate, two external), which have to be assembled.
- The tolerance on the joints between the modules is expected to be **< mm**.

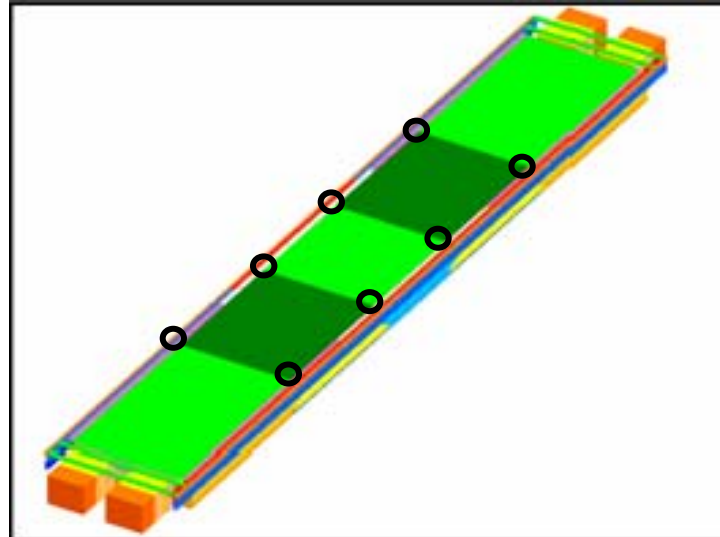



SUPERMODULES IN THE SPACE FRAME

tolerance on the space frame:
 $\pm 4 \text{ mm}$ (x, y), $\pm 5 \text{ mm}$ (z).

tolerance on the supermodules:
 $\sim 5 \text{ mm}$ (x, y, z).

- Positioning of the 18 SUPERMODULES inside the space frame:
 - *three spatial coordinates (x, y, z) for four precise reference points (→ **fiducial marks**) for each supermodule*



$$3 \times 4 \times 18 = 216$$

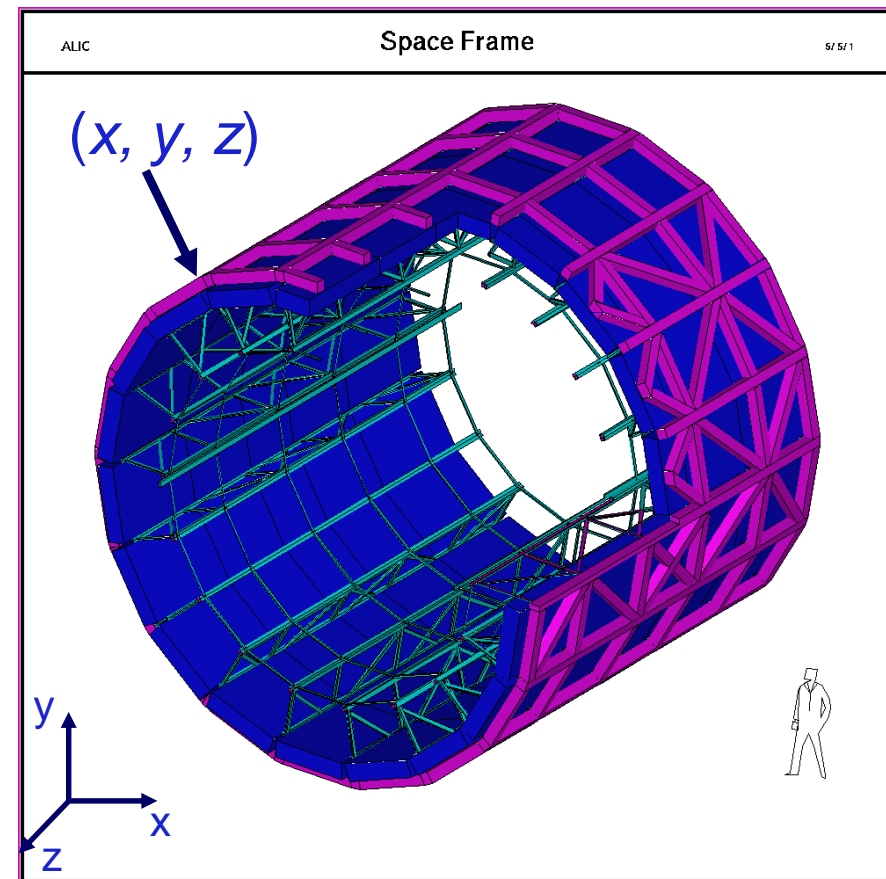



SPACE FRAME DEFORMATION

- A key point wrt TOF alignment (as for other detectors!) is the deformation of the Space Frame which occurs during the installation of the detectors.

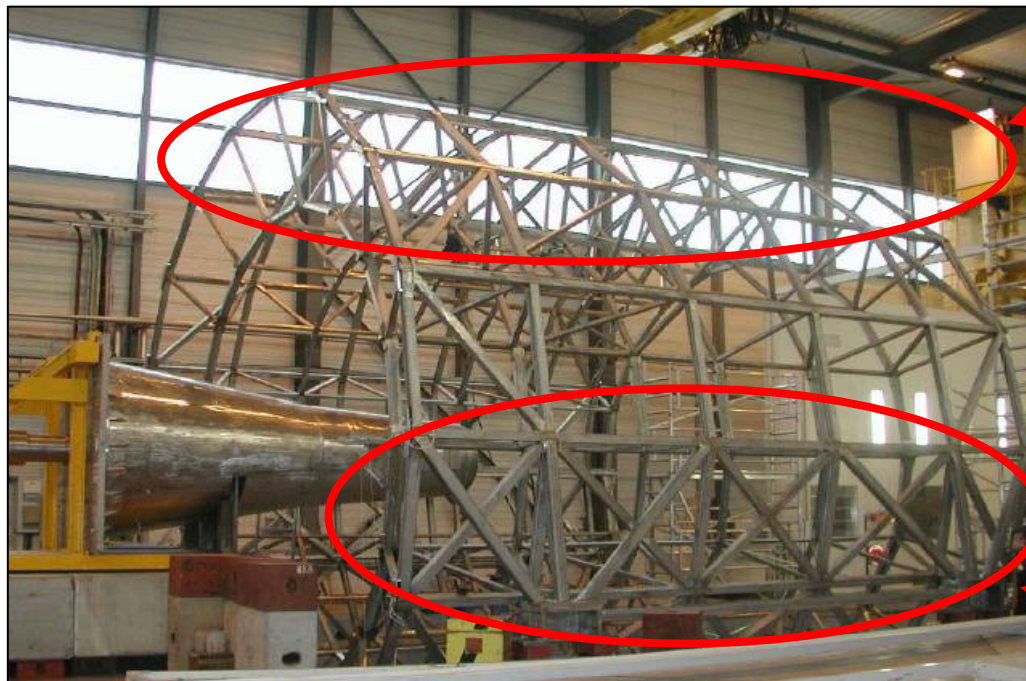

Deformable
part

Anyway, these
deformations can
be compensated!

Rigid part
(crossings, legs)

ALICE-PR-2005-092, D. Perini



SPACE FRAME OVALING

- When all the detectors will have been loaded in the Space Frame, the horizontal diameter will grow by ~ 1.5 mm, while the vertical diameter will decrease by ~ 5 mm.
- This effect **cannot be compensated!** and strongly depends on the loading sequence (symmetric left-right and up-down loading preferred).

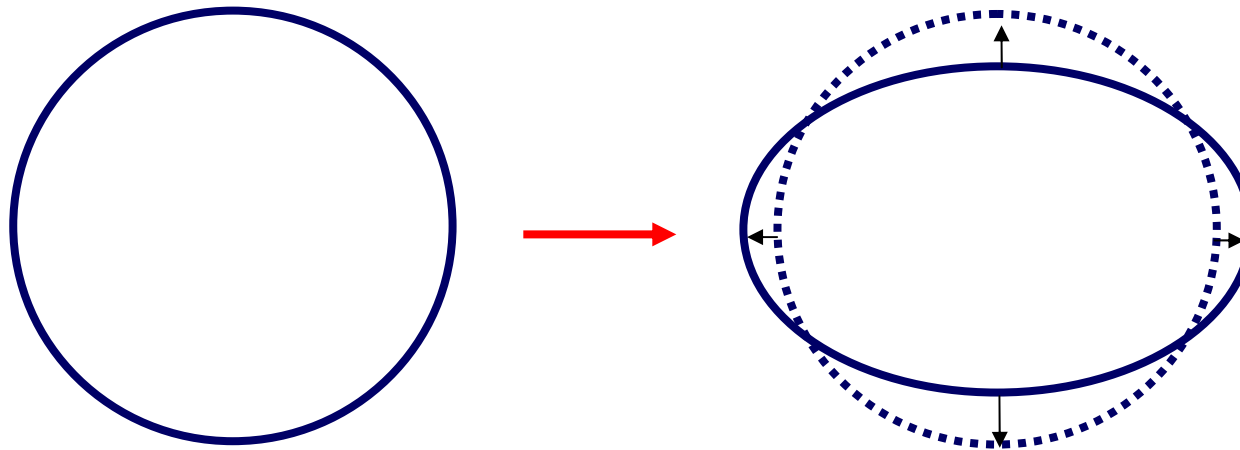

Results from tests made with simulated detectors weights (tubes full of water).
Measures performed with the theodolite, and with a laser cameras procedure.



SUPERMODULE FIDUCIAL MARKS

- The final position of the supermodules will depend on the Space Frame deformations.
- In particular, the positioning of the **fiducial marks** is still not defined. Because of the high number of cables and the extremely crowded environment (cooling system, electronics..), it will be probably fixed **on site at the end** of the assembly.

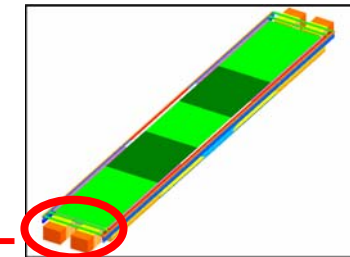
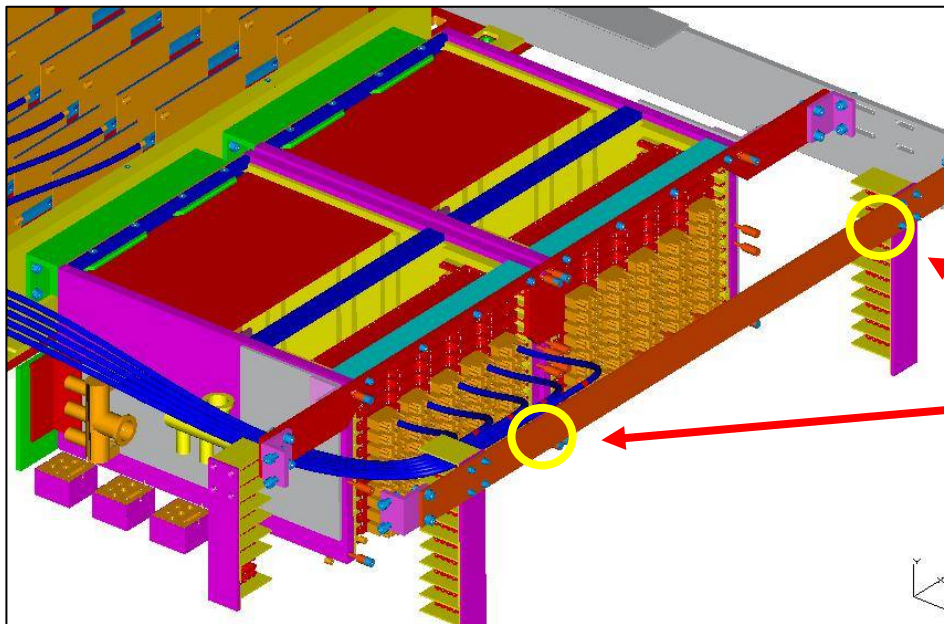

➤ The fiducial marks will be likely to be put somewhere here, on the most external part of the supermodule.



ALIGNMENT DB PARAMETERS

- TOF Alignment DB will contain information on the **positions** of the **strips** in the modules and of the **supermodules** in the space frame.
 - The positions of the strips inside the modules will be identified by two coordinates (h, θ) .
 - The positions of the supermodules in the space frame will be identified by three coordinates (x, y, z) for four points.
- The information regarding the **joints** between the modules inside the supermodules could be stored in the DB as well, but this has not been fixed yet.

All floating point constants!



UPDATE/ACCESS FREQUENCY

TYPE of CONSTANTS	UPDATE FREQUENCY	ACCESS FREQUENCY
supermodules' alignment in frame	every alignment cycle	every alignment cycle
strips' positioning in modules	once for all	once for all



ALIGNMENT STRATEGIES

- The results of the surveyors' measurements (with theodolites, lasers,...) will be opportunely taken into account in the TOF reconstruction through traslation/rotation matrices in the TOF Geometry AliRoot class (AliTOFGeometry.h/cxx).
- An offline alignment could be performed using high p_t tracks which have been well reconstructed by TRD.
- To be noted that:
 - on Pb-Pb events the offline method with reconstructed tracks will not be feasible because of the TOF occupancy;
 - on the other hand, even if in p-p events, a very high number of tracks would be necessary.



The offline alignment is an open issue!



SUMMARY & CONCLUSIONS

- The **TOF alignment** concerns:
 - the positioning of the **strips** in the modules;
 - the positioning of the **supermodules** in the space frame.
- The precision with which the TOF will be aligned strongly depends on the **tolerances** on the screws, the joints, the modules, and the **space frame** as well.
- The space frame will affect the TOF alignment also in terms of its **deformations**.
- The TOF Alignment will be implemented mainly as matrices in the **TOF Geometry** AliRoot class even if some thoughts have been done concerning a possible **software algorithm**.