

Electroweak Corrections to Four-Fermion Production

Stefan Dittmaier
MPI Munich

(in collaboration with A. Denner, M. Roth and L.H. Wieders)

Based on PLB 612 (2005) 223 [[hep-ph/0502063](#)] and [hep-ph/0505042](#)

Contents

1 Introduction

2 Features of the calculation

3 Numerical results

4 Conclusions

1 Introduction

W-pair production at LEP2

- cross-section measurement with $\Delta\sigma_{WW}/\sigma_{WW} \sim 1\%$
↪ significance of non-universal electroweak corrections
- M_W from threshold cross section with $\Delta M_W \sim 200 \text{ MeV}$
- M_W from direct reconstruction with $\Delta M_W \sim 40 \text{ MeV}$
↪ strengthening of M_H bounds
- constraints on anomalous triple gauge-boson couplings (TGC) at level of a few %
↪ verification of gauge structure

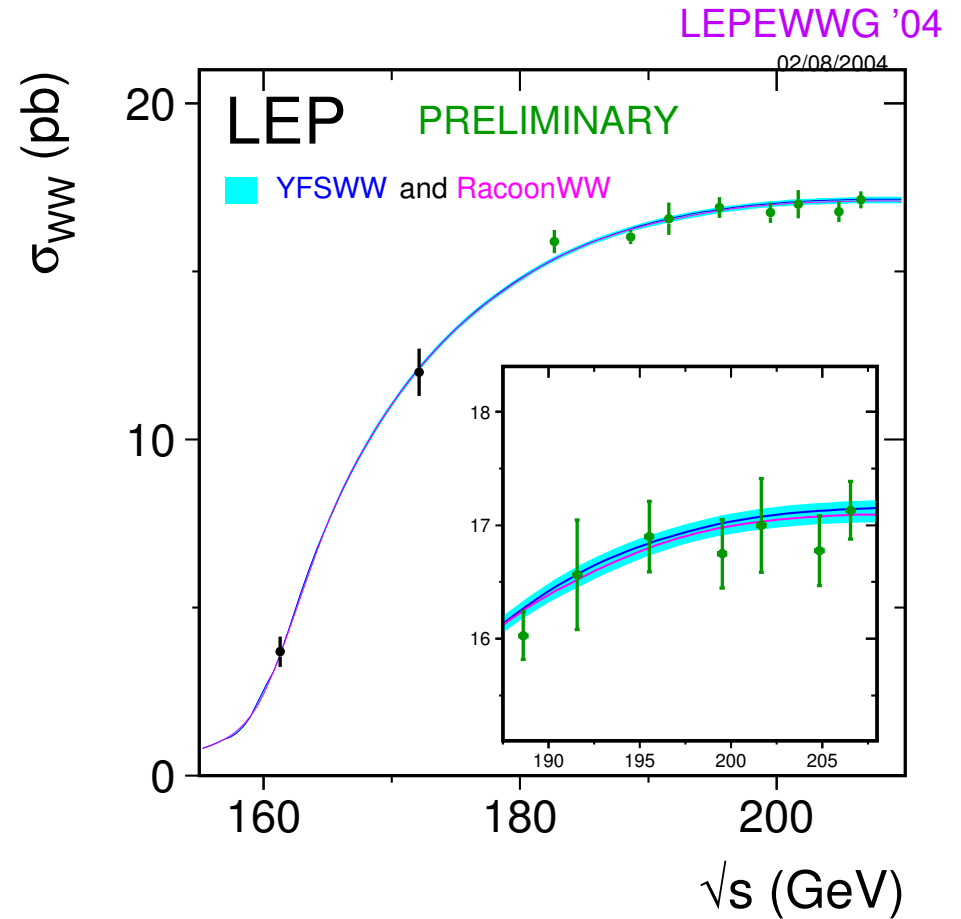

Predictions for $e^+e^- \rightarrow WW \rightarrow 4f(+\gamma)$ at LEP2

- lowest-order predictions based on full $e^+e^- \rightarrow 4f(+\gamma)$ matrix elements
- universal radiative corrections
 \hookrightarrow “improved Born approximations” (IBA)
- non-universal radiative corrections from pole expansions
 \hookrightarrow “double-pole approximations” (DPA)

Beenakker, Berends, Chapovsky '98
 Jadach et al. '99–'01
 Denner, S.D., Roth, Wackerath '99–'01
 Kurihara, Kuroda, Schildknecht '01

\Rightarrow state-of-the-art generators:

KoralW \oplus *YFSWW* (Jadach, Płaczek, Skrzypek, Ward) and
RacoonWW (Denner, S.D., Roth, Wackerath)

Estimates of theoretical uncertainties (TU) for

- total cross section (Denner et al., Jadach et al.)

$$\Delta\sigma_{WW}/\sigma_{WW} \lesssim \begin{cases} 2\% & \text{for } \sqrt{s} < 170 \text{ GeV} & \text{(IBA)} \\ 0.7\% & \text{for } 170 \text{ GeV} < \sqrt{s} < 180 \text{ GeV} & \text{(DPA)} \\ 0.5\% & \text{for } 180 \text{ GeV} < \sqrt{s} < 500 \text{ GeV} & \text{(DPA)} \end{cases}$$

- direct M_W reconstruction: $\Delta M_W \lesssim 5 \text{ MeV}$ (Jadach et al. '01) – 10 MeV (Cossutti '04)
- bounds on anomalous TGC λ : $\Delta\lambda \lesssim 0.005$ (Brunelière et al. '02)

W-pair production at future ILC

(see e.g. TESLA-TDR '01)

- cross-section measurement with $\Delta\sigma_{WW}/\sigma_{WW} \lesssim 0.5\%$
- M_W from threshold cross section with $\Delta M_W \sim 7 \text{ MeV}$
 \hookrightarrow IBA totally insufficient \implies
- M_W from direct reconstruction with $\Delta M_W \sim 10 \text{ MeV}$
- constraints on anomalous TGC at level of 0.1%

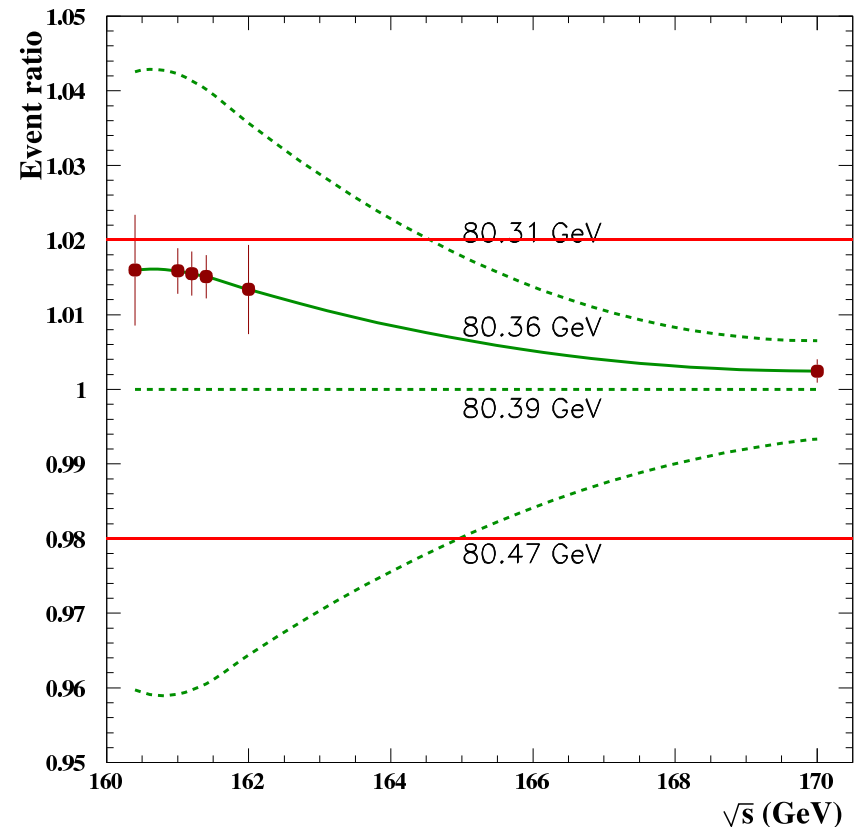

Theoretical requirements for ILC:

- full $\mathcal{O}(\alpha)$ correction for $e^+e^- \rightarrow 4f$
 \hookrightarrow subject of this talk !
- leading corrections beyond $\mathcal{O}(\alpha)$

2 Features of the calculation

Complete $\mathcal{O}(\alpha)$ corrections to $e^+e^- \rightarrow \nu_\tau \tau^+ \mu^- \bar{\nu}_\mu$ leptonic
 $u\bar{d}\mu^- \bar{\nu}_\mu$ semileptonic
 $u\bar{d}s\bar{c}$ hadronic final state

$\hookrightarrow \mathcal{O}(10^3)$ one-loop diagrams: generation with FEYNARTS versions 1 and 3
 Küblbeck, Böhm, Denner '90 Hahn '00

- 40 hexagons

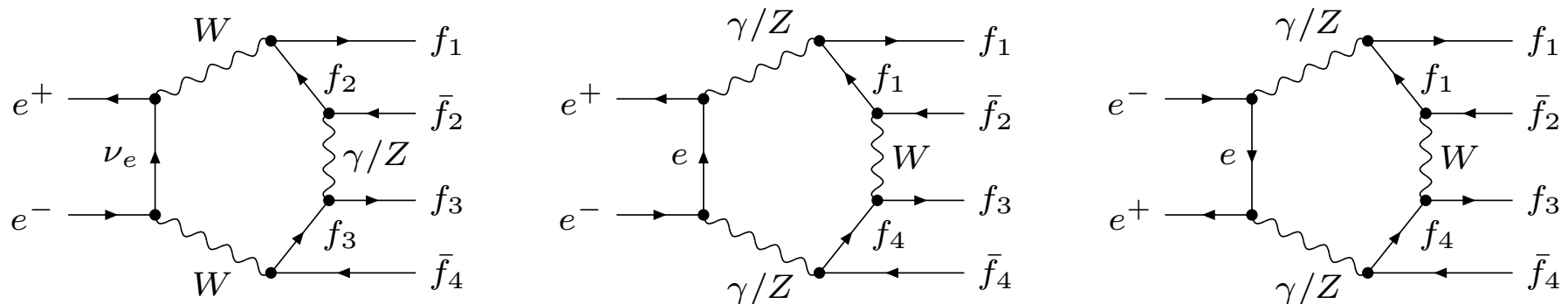

+ graphs with reversed fermion-number flow in final state

- 112 pentagons
- 227 boxes ('t Hooft–Feynman gauge)
- many vertex corrections and self-energy diagrams

Computational details:

- algebraic reduction of $\mathcal{O}(10^3)$ spinor chains

such as $\bar{v}_{e^+} \gamma^\mu \gamma^\nu \not{p}_i u_{e^-} \times \bar{u}_{f_1} \gamma_\nu \gamma^\rho \not{p}_j v_{\bar{f}_2} \times \bar{u}_{f_3} \gamma_\mu \gamma_\rho \not{p}_k v_{\bar{f}_4}$

↪ $\mathcal{O}(10)$ standard structures with well-behaved coefficients

- complex gauge-boson masses everywhere, i.e., also in couplings

$$c_W^2 = 1 - s_W^2 = \frac{M_W^2 - iM_W \Gamma_W}{M_Z^2 - iM_Z \Gamma_Z}$$

↪ gauge-invariant result !

(Slavnov–Taylor identities and gauge-parameter independence)

↪ unitarity cancellations respected !

but: complex gauge-boson masses in all loop integrals

- algebraic reduction of 5- and 6-point integrals (4-dim. of space-time)

without inverse Gram determinants:

5-point integrals → five 4-point integrals

Melrose '65; Denner, S.D. '02

6-point integrals → six 5-point integrals

Melrose '65; Denner '93

Numerical problems:

Passarino–Veltman reduction of 2-point to 4-point tensor integrals

↔ inverse Gram determinants of up to three momenta

↔ **serious numerical instabilities where $\det G \rightarrow 0$**
(at phase-space boundary but not only !)

Solutions:

- **2-point functions:** numerically stable direct calculation possible

- **3-/4-point functions:** **two alternative “rescue systems”**

Variant 1: **appropriate expansions** of tensor coefficients
in small Gram determinants

Variant 2: **numerical evaluation of one appropriate tensor coefficient**
(logarithmic Feynman-parameter integral)
and algebraic reduction to this basis integral

Checks:

- **UV structure** of virtual corrections
↔ independence of reference mass μ of dimensional regularization
- **IR structure** of virtual + soft-photon corrections
↔ independence of $\ln m_\gamma$ (m_γ = infinitesimal photon mass)
- **mass singularities** of virtual + related collinear photonic corrections
↔ independence of $\ln m_{f_i}$ (m_{f_i} = small masses of external fermions)
- **gauge invariance** of amplitudes with $\Gamma_W, \Gamma_Z \neq 0$
↔ identical results in 't Hooft–Feynman and background-field gauge
Denner, S.D., Weiglein '94
- **real corrections**
↔ taken from RACOONWW
- **combination of virtual and real corrections**
↔ identical results with two-cutoff slicing and dipole subtraction
S.D. '99; Roth '00
- **two completely independent calculations of all ingredients !**

3 Numerical results

Complete $\mathcal{O}(\alpha)$ corrections to the total cross section – LEP2 energies

Denner, S.D., Roth, Wieders '05

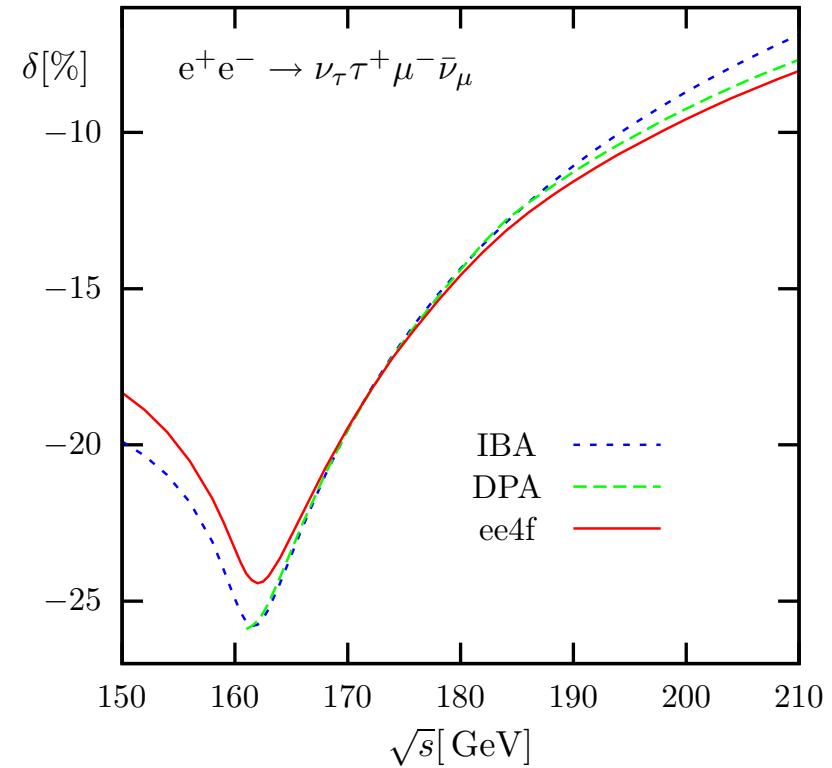
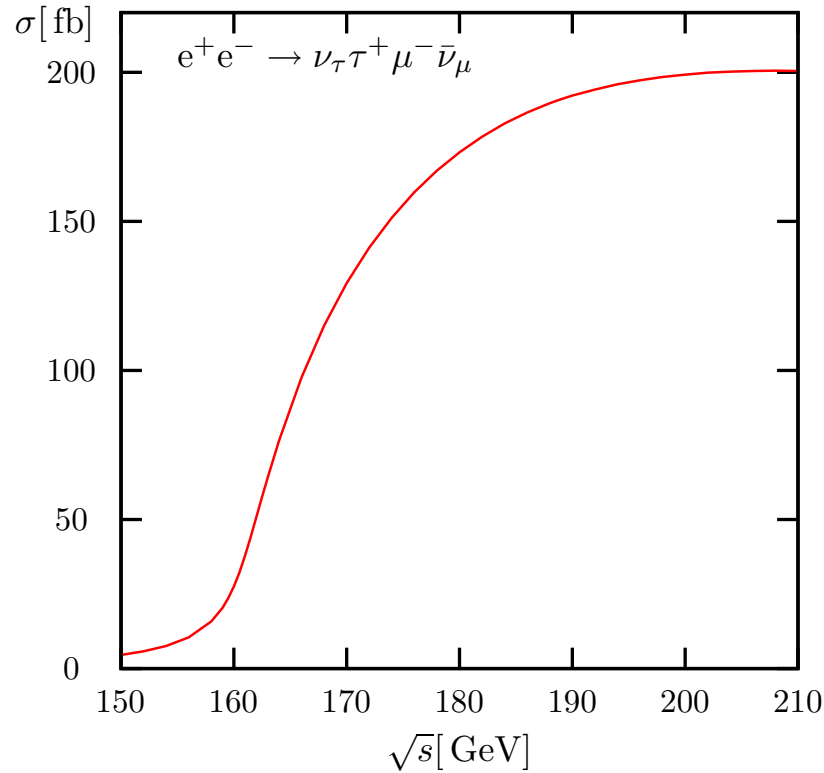

- $|\text{ee4f} - \text{DPA}| \sim 0.5\%$ for $170 \text{ GeV} \lesssim \sqrt{s} \lesssim 210 \text{ GeV}$
- $|\text{ee4f} - \text{IBA}| \sim 2\%$ for $\sqrt{s} \lesssim 170 \text{ GeV}$

↪ agreement with error estimates of DPA and IBA

Complete $\mathcal{O}(\alpha)$ corrections to the total cross section – ILC energies

Denner, S.D., Roth, Wieders '05

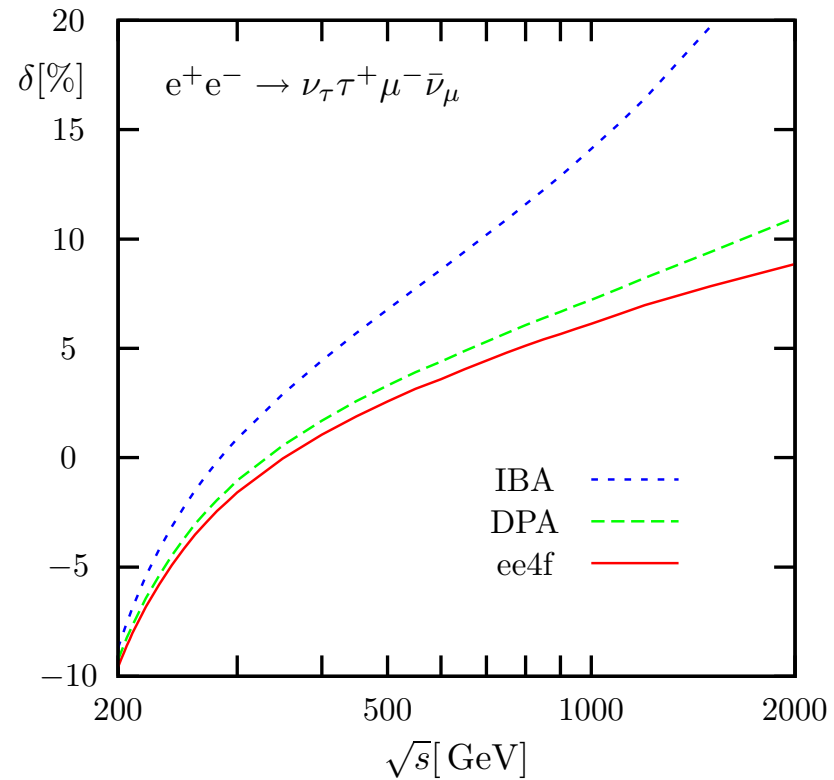
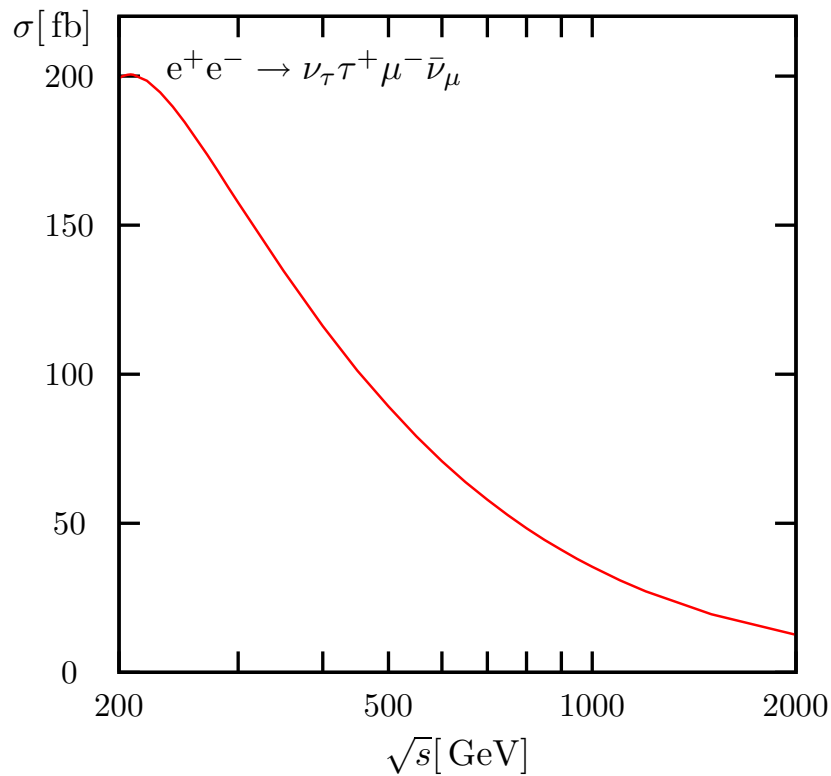

- $|\text{ee4f} - \text{DPA}| \sim 0.7\%$ for $200 \text{ GeV} \lesssim \sqrt{s} \lesssim 500 \text{ GeV}$
↪ agreement with error estimate of DPA
- $|\text{ee4f} - \text{DPA}| \sim 1-2\%$ for $500 \text{ GeV} \lesssim \sqrt{s} \lesssim 1-2 \text{ TeV}$

W-production angle distribution at $\sqrt{s} = 200$ GeV

$\frac{d\sigma}{d \cos \theta_{W^+}}$ [fb]

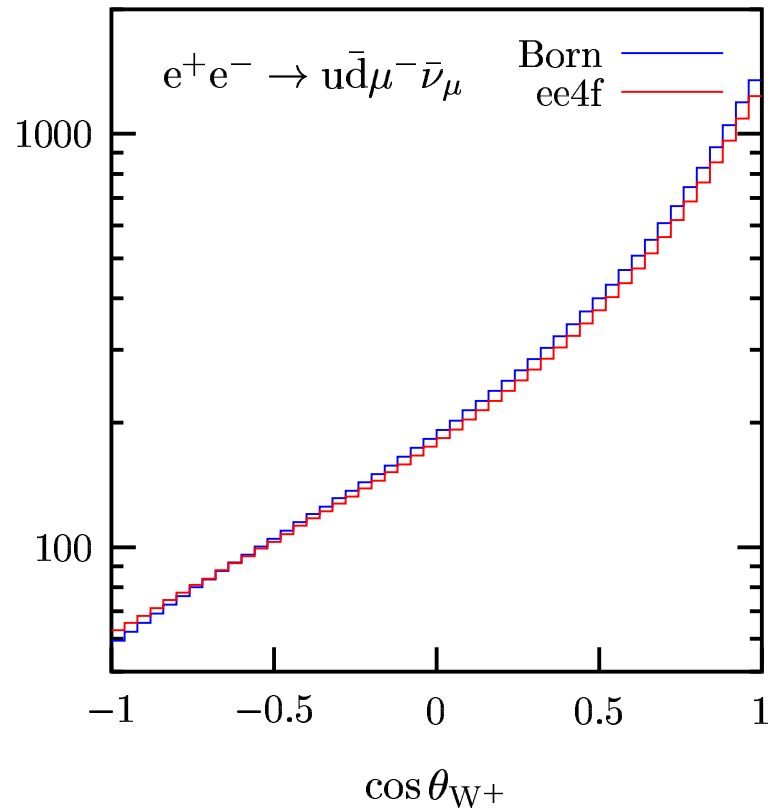

Denner, S.D., Roth, Wieders '05

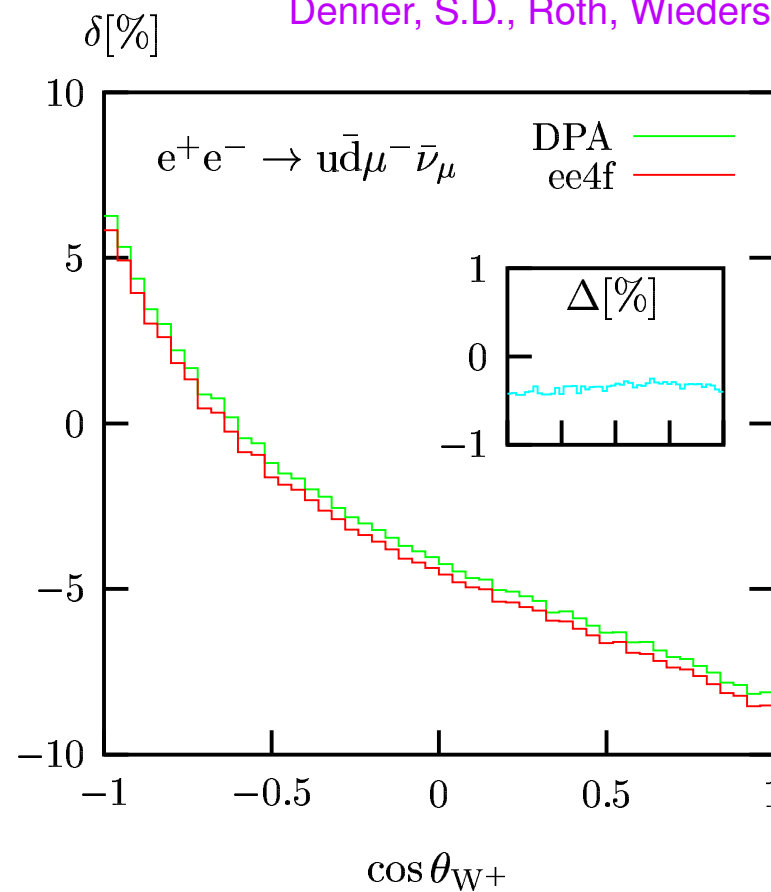

$$\Delta = ee4f - DPA$$

No visible distortion of shape w.r.t. DPA at LEP2 energies

W-production angle distribution at $\sqrt{s} = 500$ GeV

$\frac{d\sigma}{d \cos \theta_{W^+}}$ [fb]

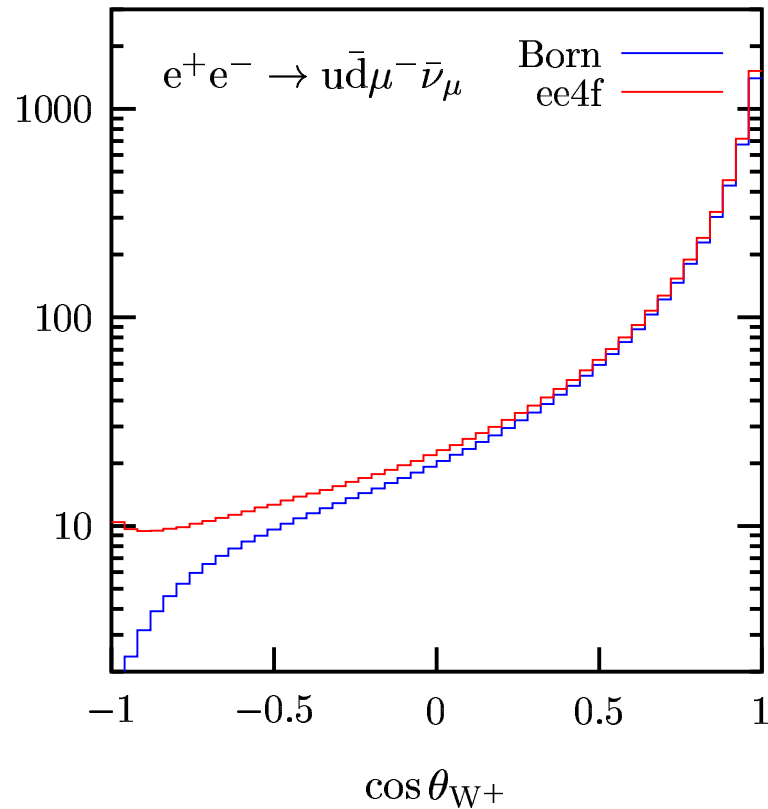

Denner, S.D., Roth, Wieders '05

δ [%]

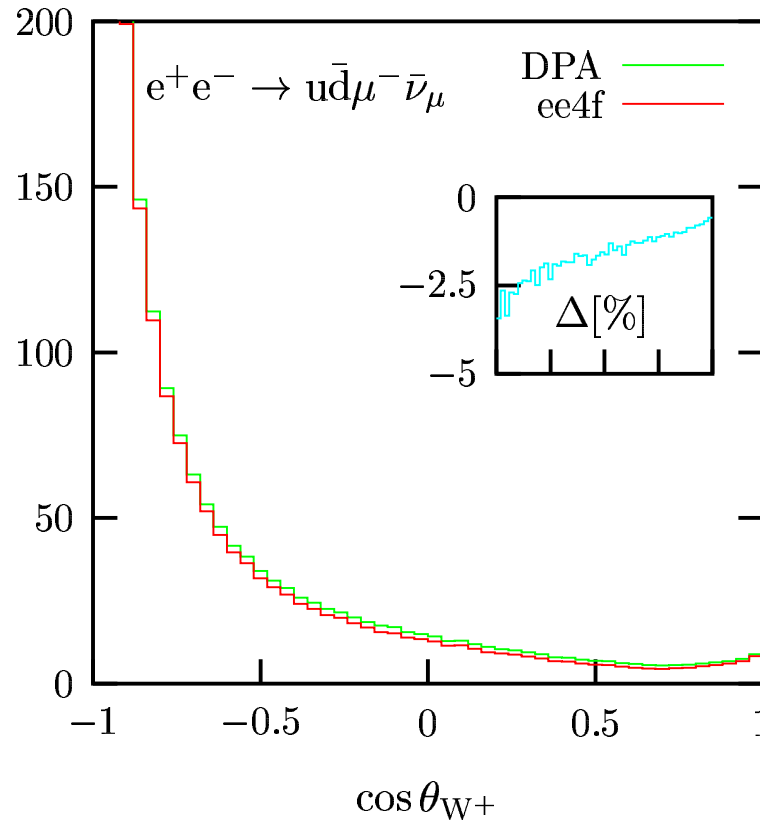

$\Delta = ee4f - \text{DPA}$

Significant distortion of shape w.r.t. DPA at ILC energies

↪ Important for TGC studies at ILC

W-invariant-mass distribution at $\sqrt{s} = 200 \text{ GeV}$

(photon recombination applied)

$$\frac{d\sigma}{dM_{W^+}} \left[\frac{\text{fb}}{\text{GeV}} \right]$$

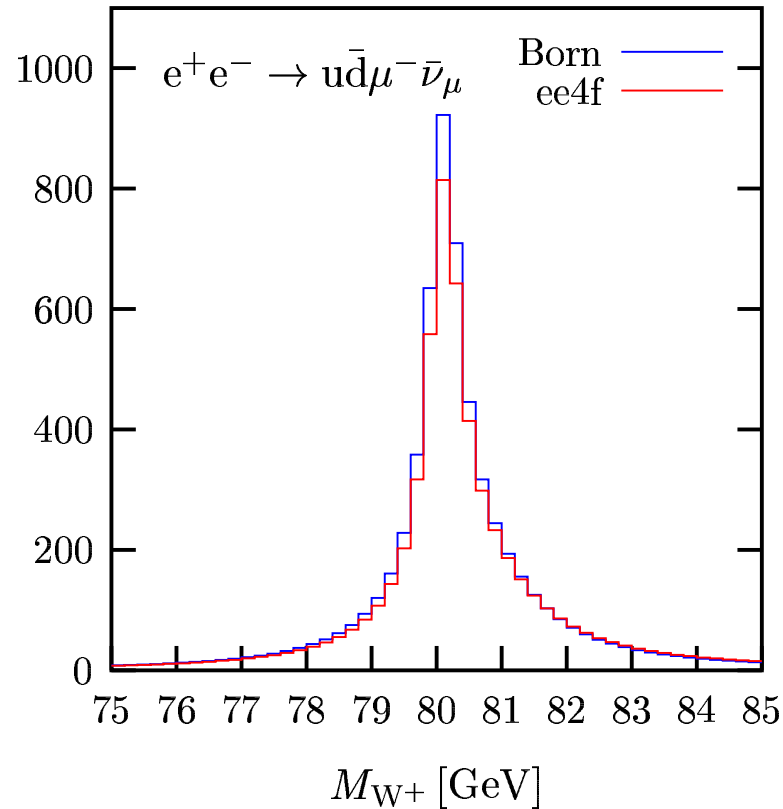

Denner, S.D., Roth, Wieders '05

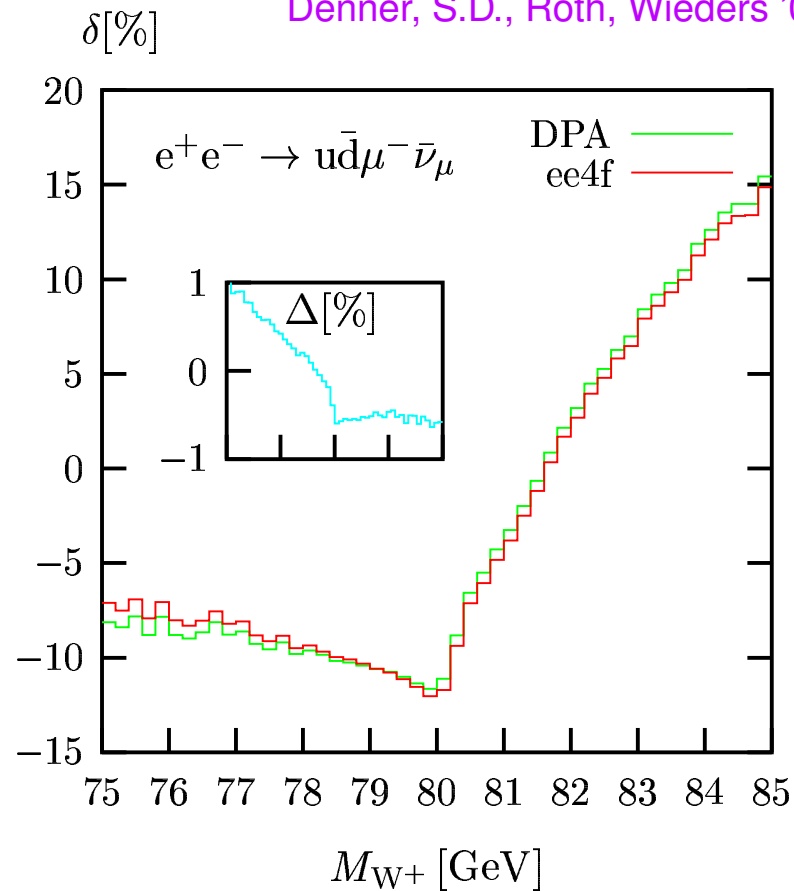

$$\Delta = ee4f - \text{DPA}$$

Small distortion of shape w.r.t. DPA at LEP2 energies

↪ Shift in M_W in direct reconstruction ?

4 Conclusions

W-pair production at future ILC requires

- full $\mathcal{O}(\alpha)$ correction for $e^+e^- \rightarrow 4f$
- leading corrections beyond $\mathcal{O}(\alpha)$

Complete $\mathcal{O}(\alpha)$ correction for $e^+e^- \rightarrow \nu_\tau\tau^+\mu^-\bar{\nu}_\mu, u\bar{d}\mu^-\bar{\nu}_\mu, u\bar{d}s\bar{c}$ calculated

- **new techniques** in the calculation:
 - ◇ complex gauge-boson masses
 - ◇ new tensor reductions
- **new Monte Carlo generator:** RACOONWW \rightarrow RACOON4F
- **theoretical uncertainty at threshold reduced from $\sim 2\%$ to a few 0.1%**
- benchmark results published
 - \hookrightarrow comparison with future results of **Grace/1-loop** ?
(progress reported at Loops&Legs 2004)

Remaining theoretical uncertainties dominated by

- **electroweak effects beyond $\mathcal{O}(\alpha)$** , e.g. $(\frac{\alpha}{\pi})^2 \ln(\frac{m_e^2}{s}) \sim 0.1\%$
- **QCD effects** (matching between matrix elements and parton shower)