



International ICFA workshop on HEP
Networking, Grids, Digital Divide and Global e-
Science Daegu, Korea

May 23~27, 2005

HEP as e-Science



Kihyeon Cho

**Center for High Energy Physics
Kyungpook National University**

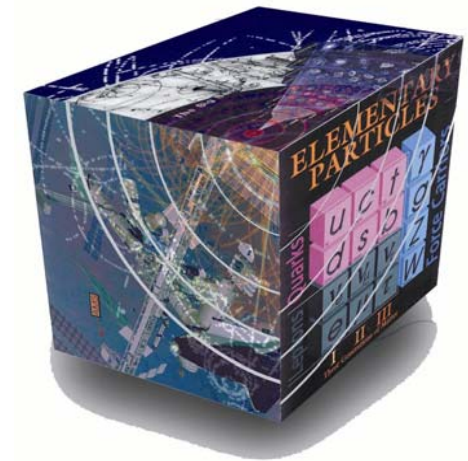

Why HEP e-Science?

- LHC @ CERN

- LHC Data: 12~14 PetaByte/year
- LHC CPUs: Peta Operations of CPU

- ⇒
1. e-Science based on Grid concept
 2. Tier0, 1, 2, Regional Data Center

Korean Group is working on CMS

CMS Collaboration

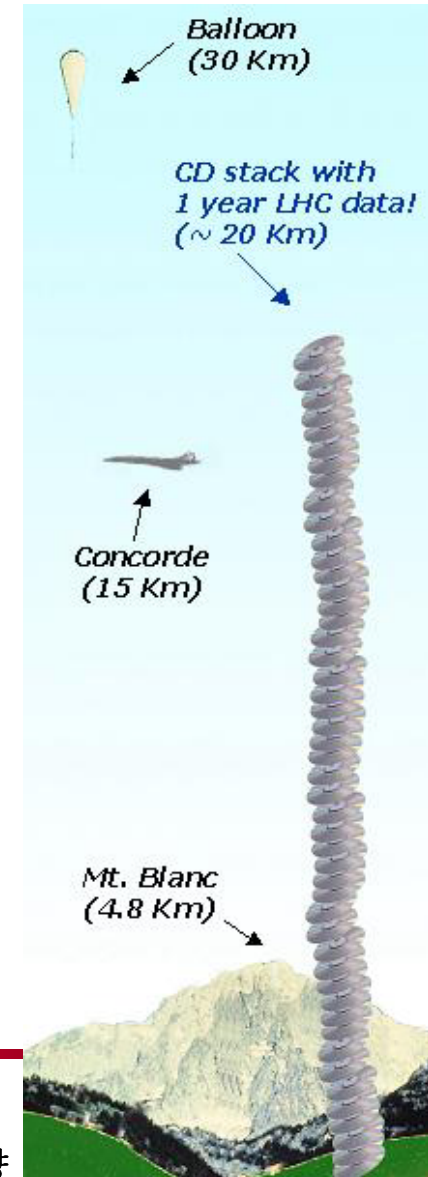
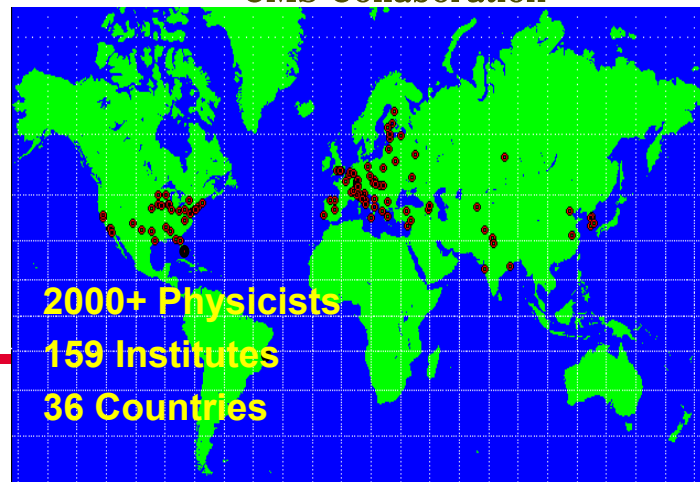



HEP e-Science efforts





HEP e-Science project around world

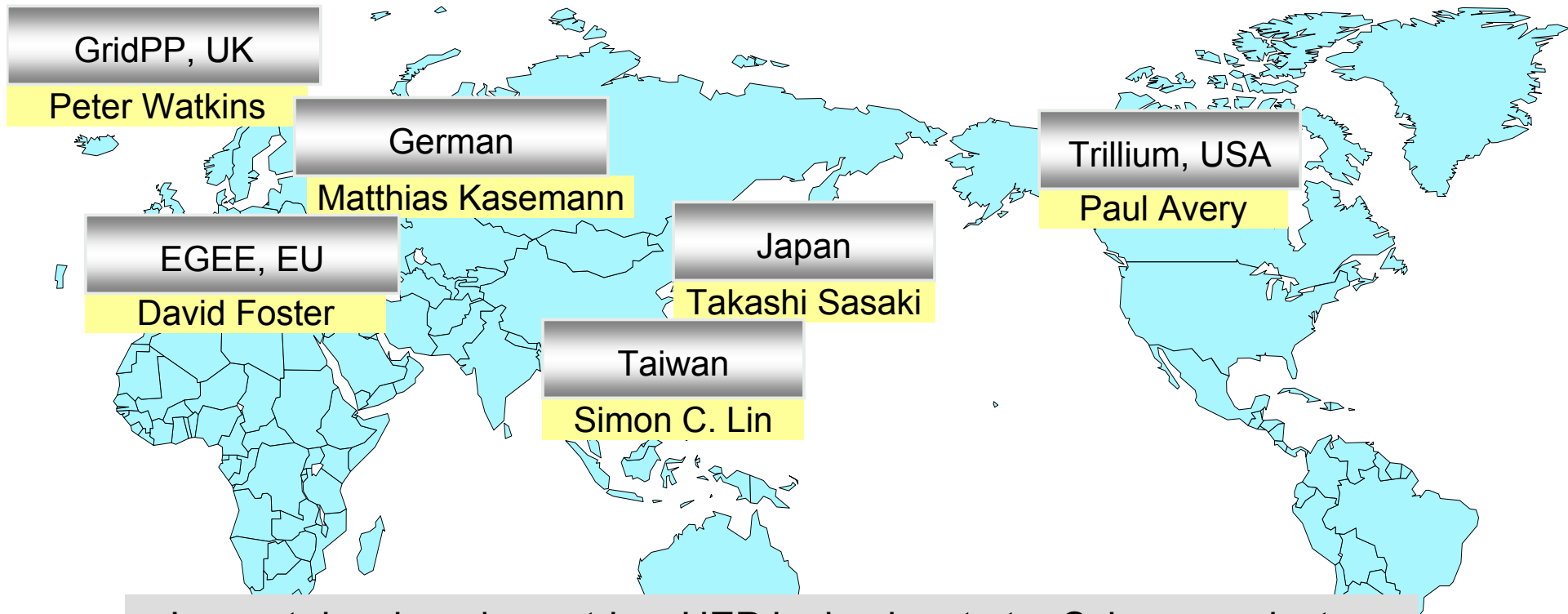

- In most developed countries, HEP is dominant at e-Science project.
- However, in Korea, this year's e-Science project does not include HEP.

=> "e-Science in Korea" by Dr. Jysoo Lee

Still going...



In Korea

Energizer Bunny®

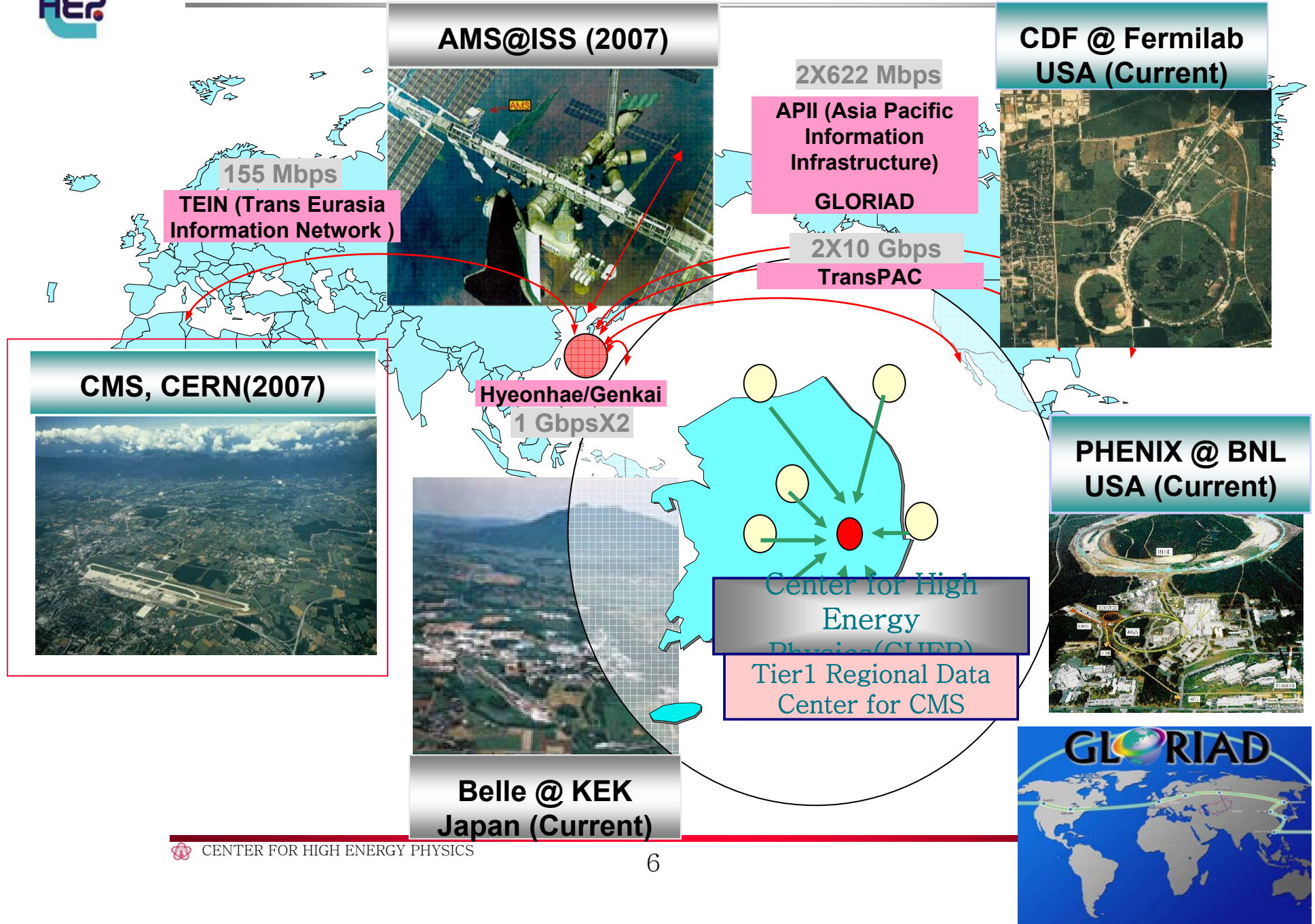



HEP e-Science in Korea

- Goal
 - Tier1 Regional Data Center for CMS
 - HEP e-Science Service Frame
- e-Science R & D
 1. Network – Bandwidth Challenge
 2. Storage – SRB Federation
 3. Computing – Data Grid Technology

HER Goal - Tier1 Regional Data Grid

~10s of Petabytes/yr by 2007-8
 ~1000 Petabytes in < 10 yrs?

CMS Experiment

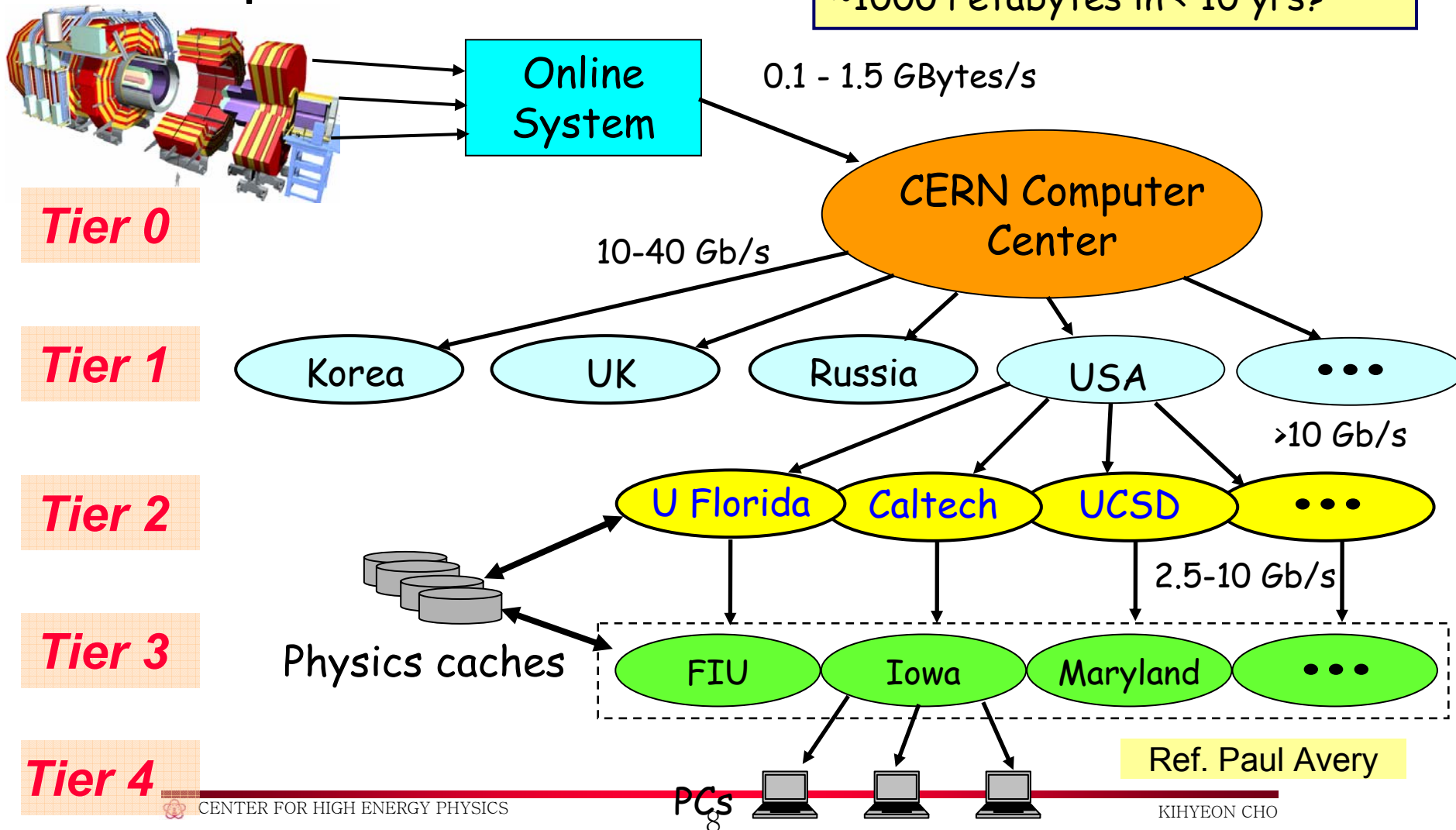

Ref. Paul Avery

HEP e-Science Service Frame

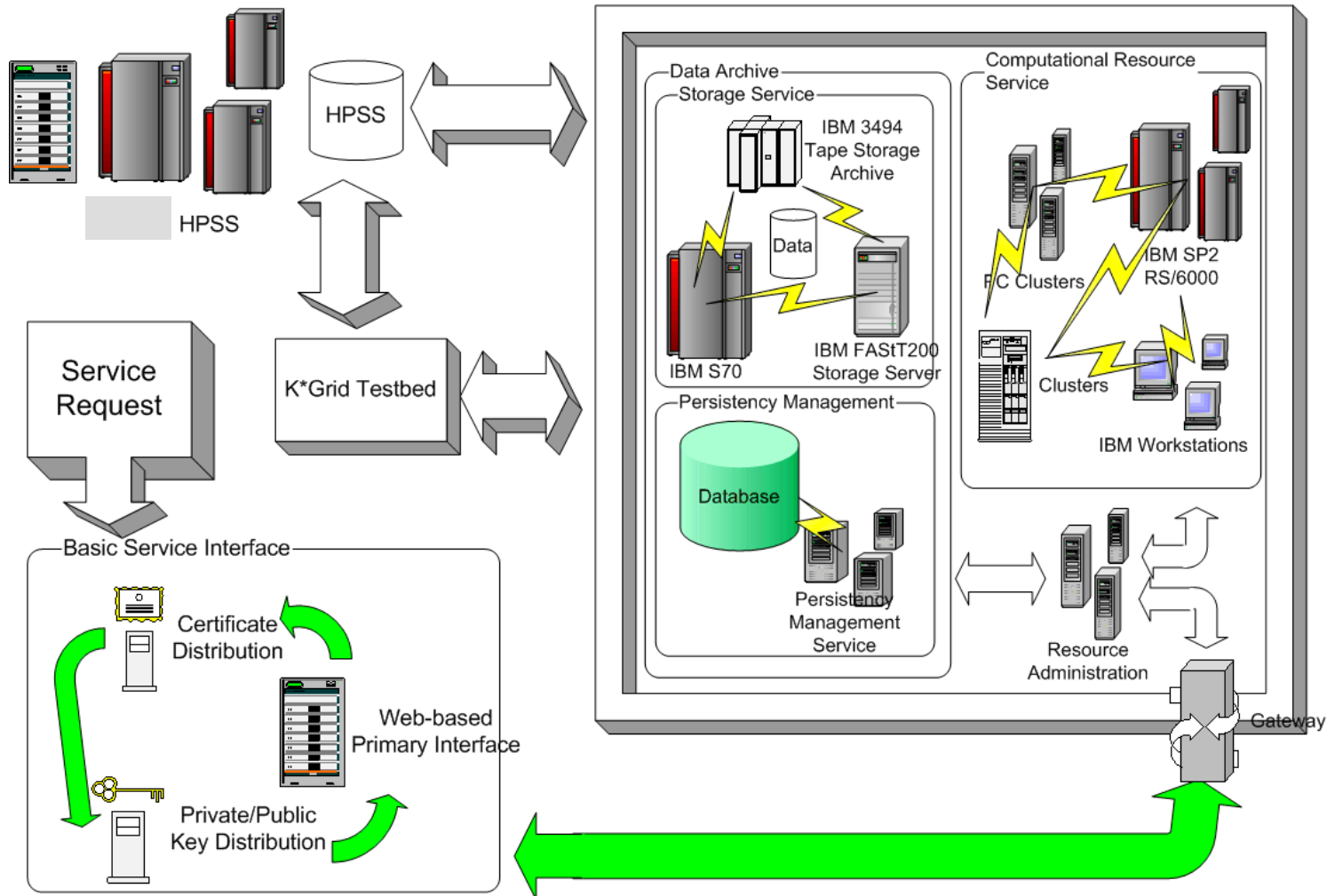



HEP e-Science Service Elements

- Web Portal
- Security
- Application Layer
- ARDA
- Grid Service based on LCG2 & Grid3
- Data storage using SRM & SRB

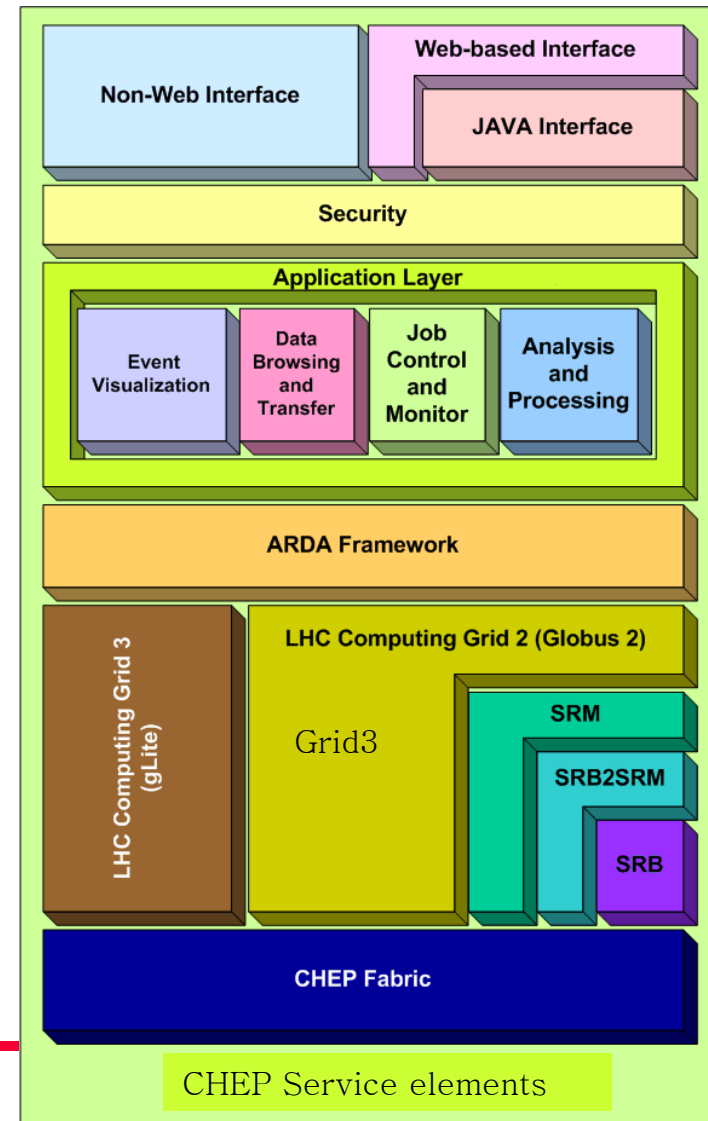

e-Science R & D



- **Regional Data Center in Korea is located at Supercomputing Center of CHEP(Center for High Energy Physics) @ KNU (Kyungpook National University)**





Current Resources @ KNU

- 45 TB Tape Library
- 10 TB Raid Disk
- ~200 CPUs of Linux clusters
- Network: 6 Gbps
- Space and power for Tier1 Data Center
- Two full time computer researchers & one post-doc



1. Network

- High Speed TeraByte Transfer for Physics
 - New Network Performance Records (101.13 Gbps) to and from Pittsburgh, USA @ SC2004
⇒ World Breaking Record
 - Participants: Caltech, SLAC, Fermilab, CERN, Florida, UK, Brazil and KNU/KISTI
⇒ 4 Continents



Network Path during SC2004

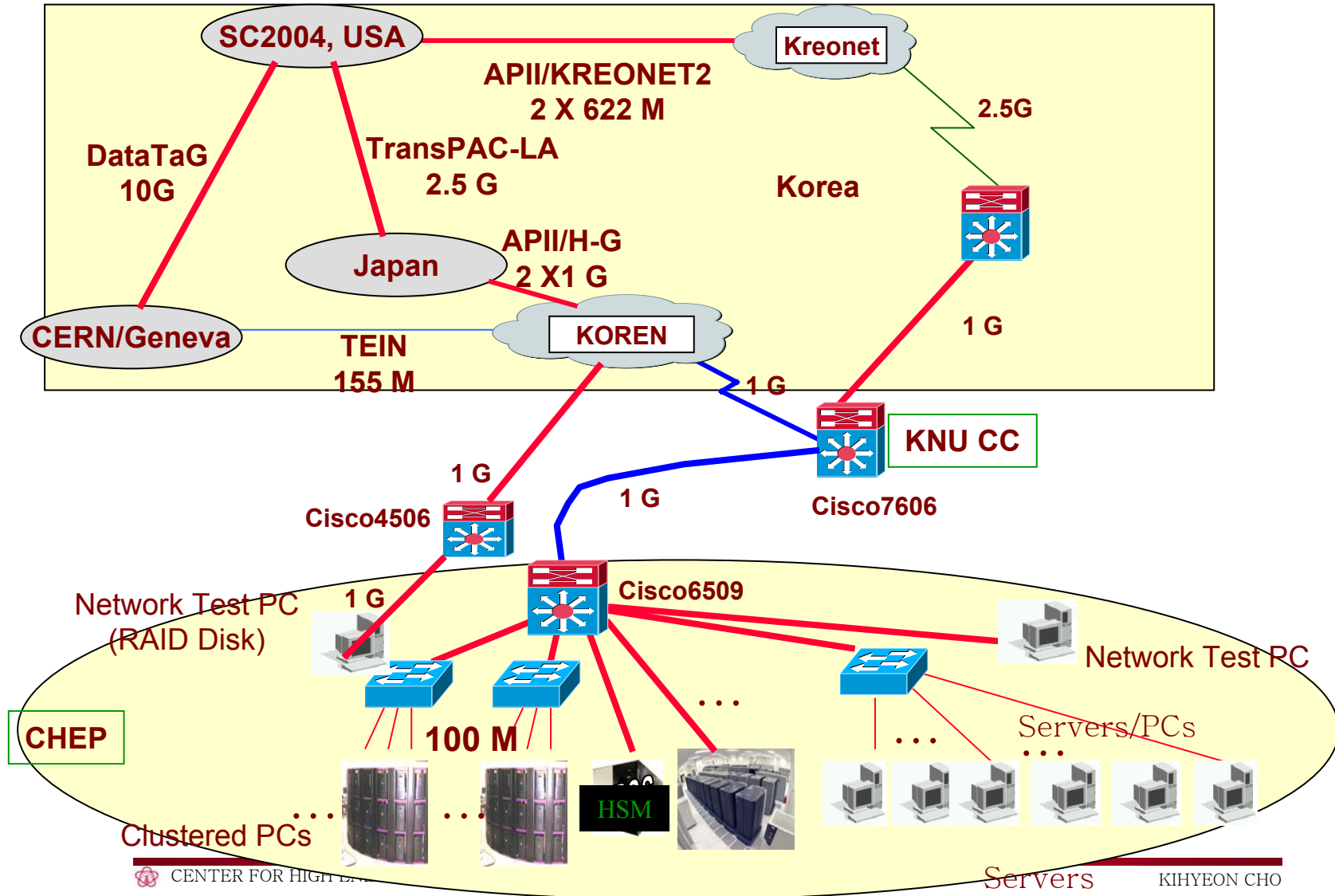



World Record (101.13Gbps)

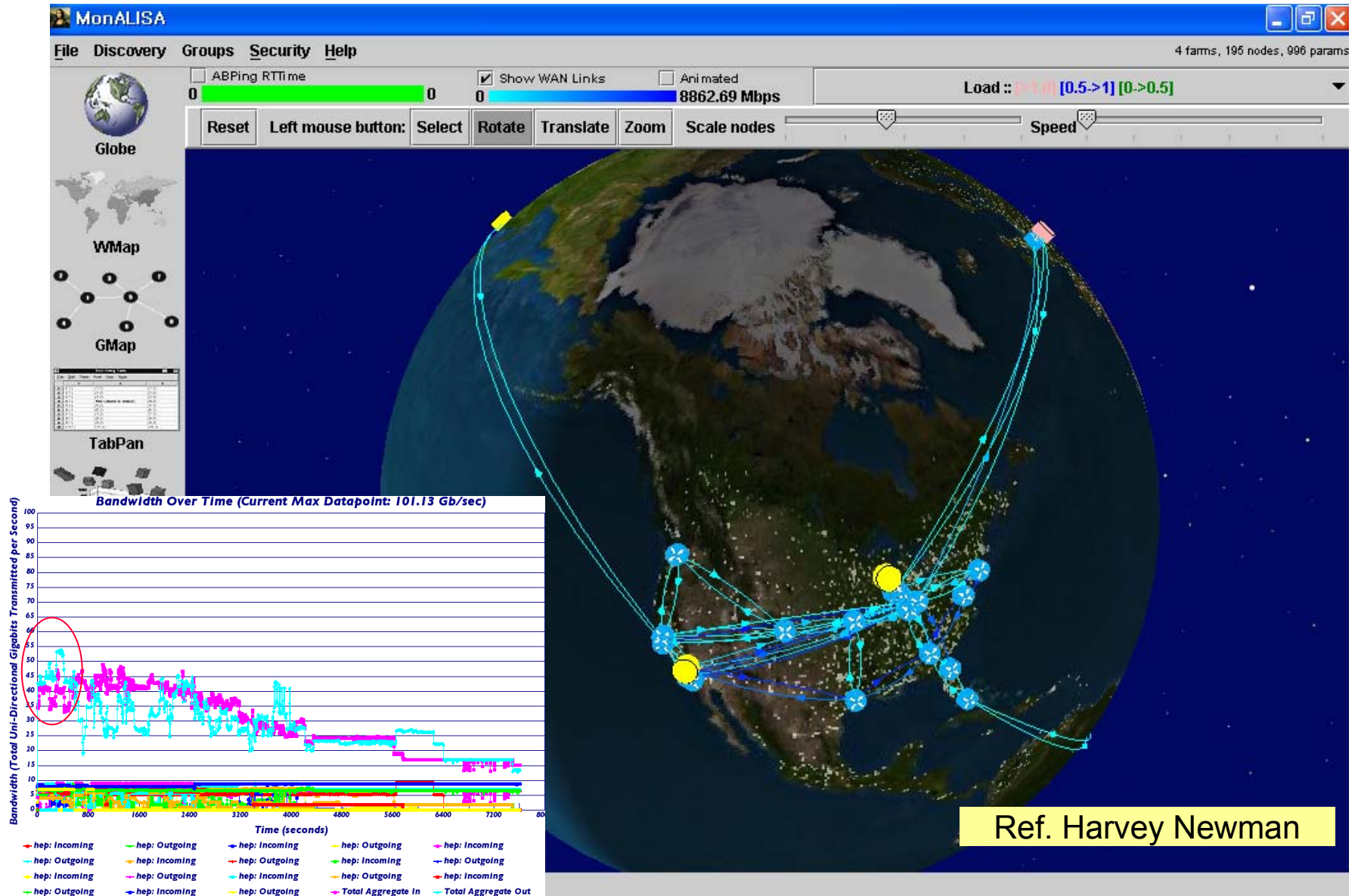



Korea-US record (1.6Gpbs)

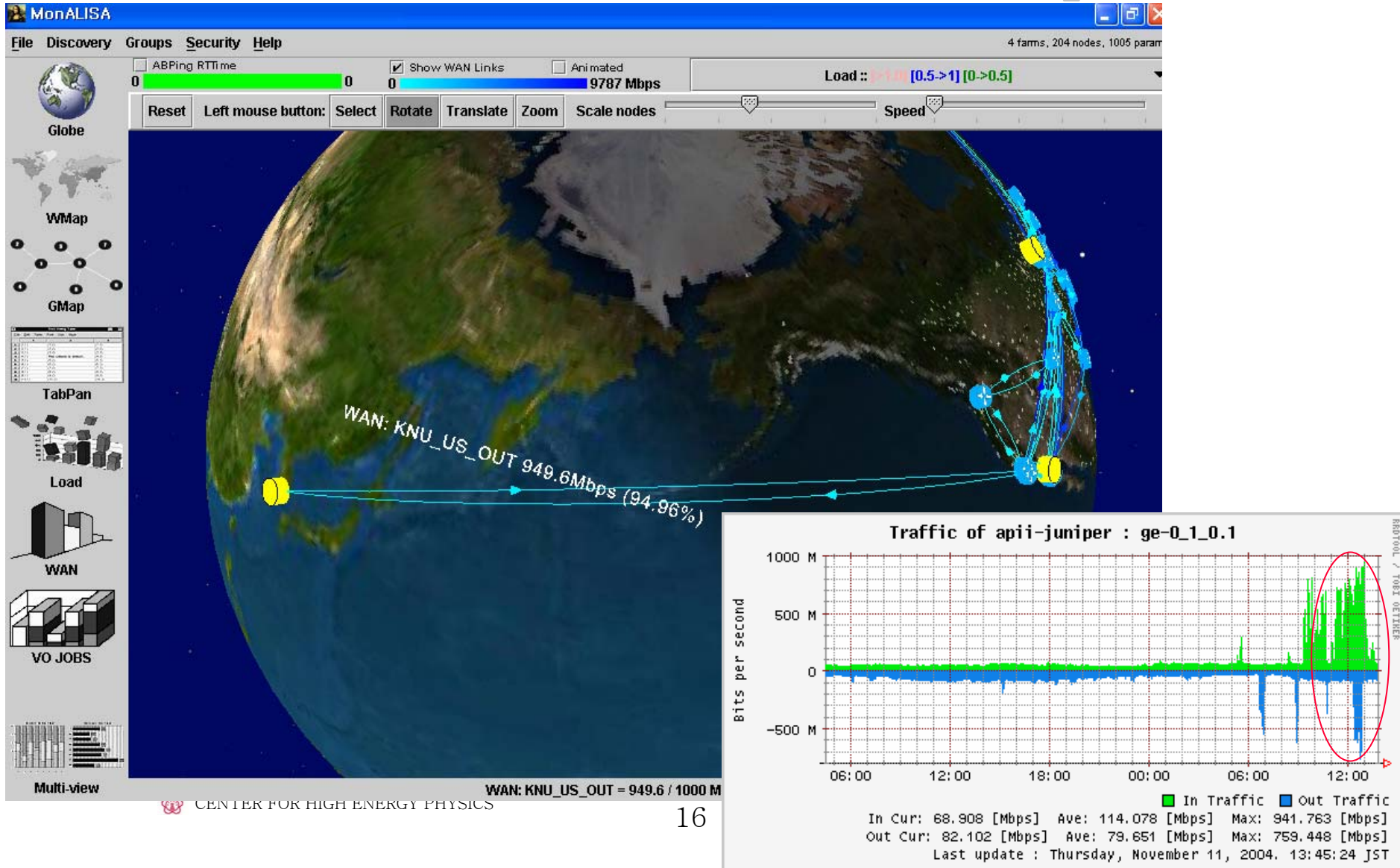

2. Storage Resource Broker

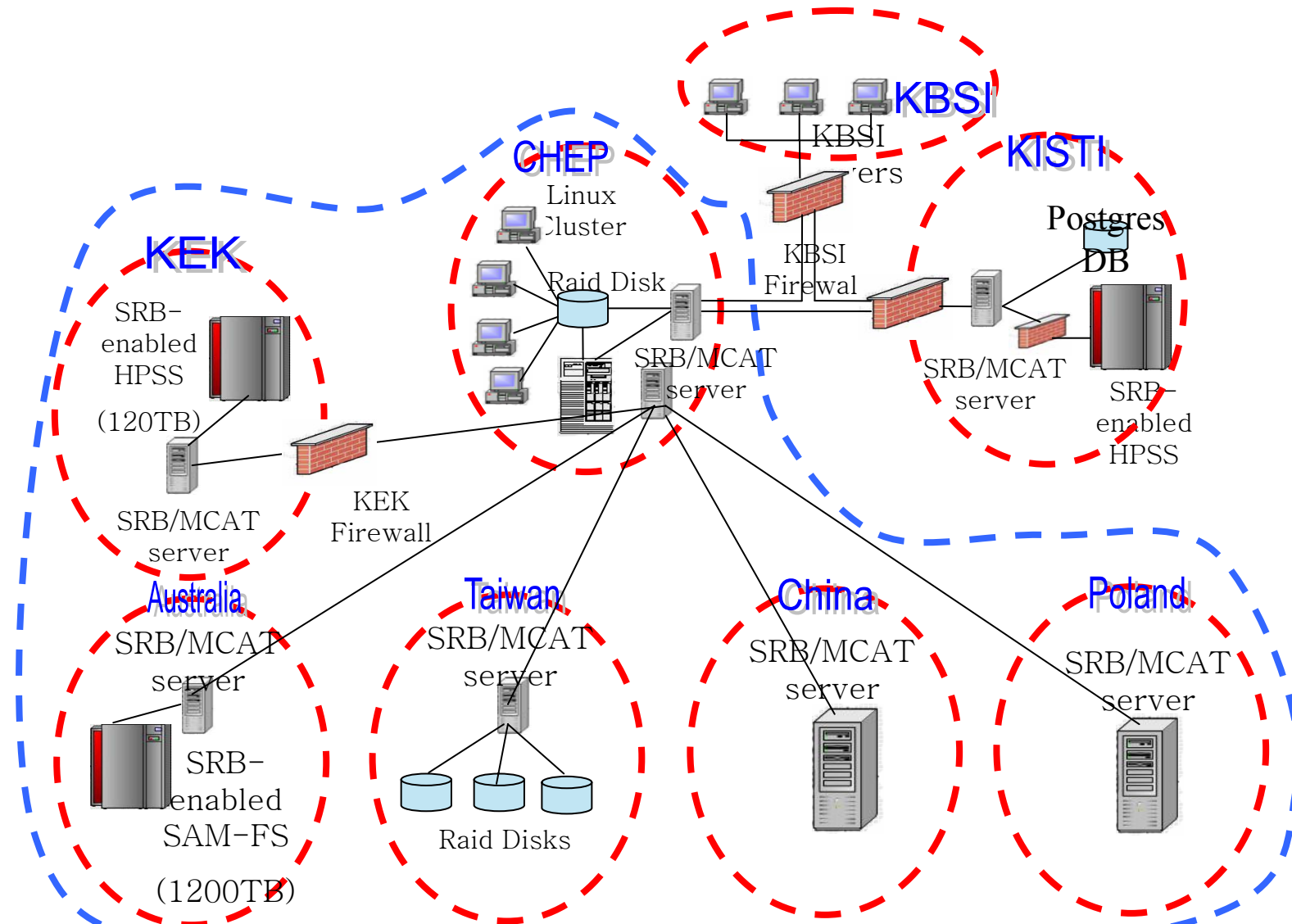

3. Computing R&D

- **Data Grid Activity (2002~)**
 - 1) SAMGrid (2002)
 - 2) DCAF(DeCentralized Analysis Farm) for CDF
 - 3) Belle Grid
 - 4) Grid3 farm for CMS
 - 5) LCG2 farm for CMS
 - 6) Interoperability

1) SAM Grid (2002)

SAM - GRID INFORMATION AND MONITORING SYSTEM - Microsoft Internet Explorer

파일(F) 편집(E) 보기(V) 즐겨찾기(A) 도구(T) 도움말(H)

주소(D) http://samadams.fnal.gov:8080/prototype/ 이동

Launching the Monitoring System:

Please click at the map to monitor the execution sites.
Click [here](#) to get information about the submission sites.

Participating Experiments:

- DO
- CDF

● KNU Site for CDF

● SC2002

2) DCAF for CDF (2003-)

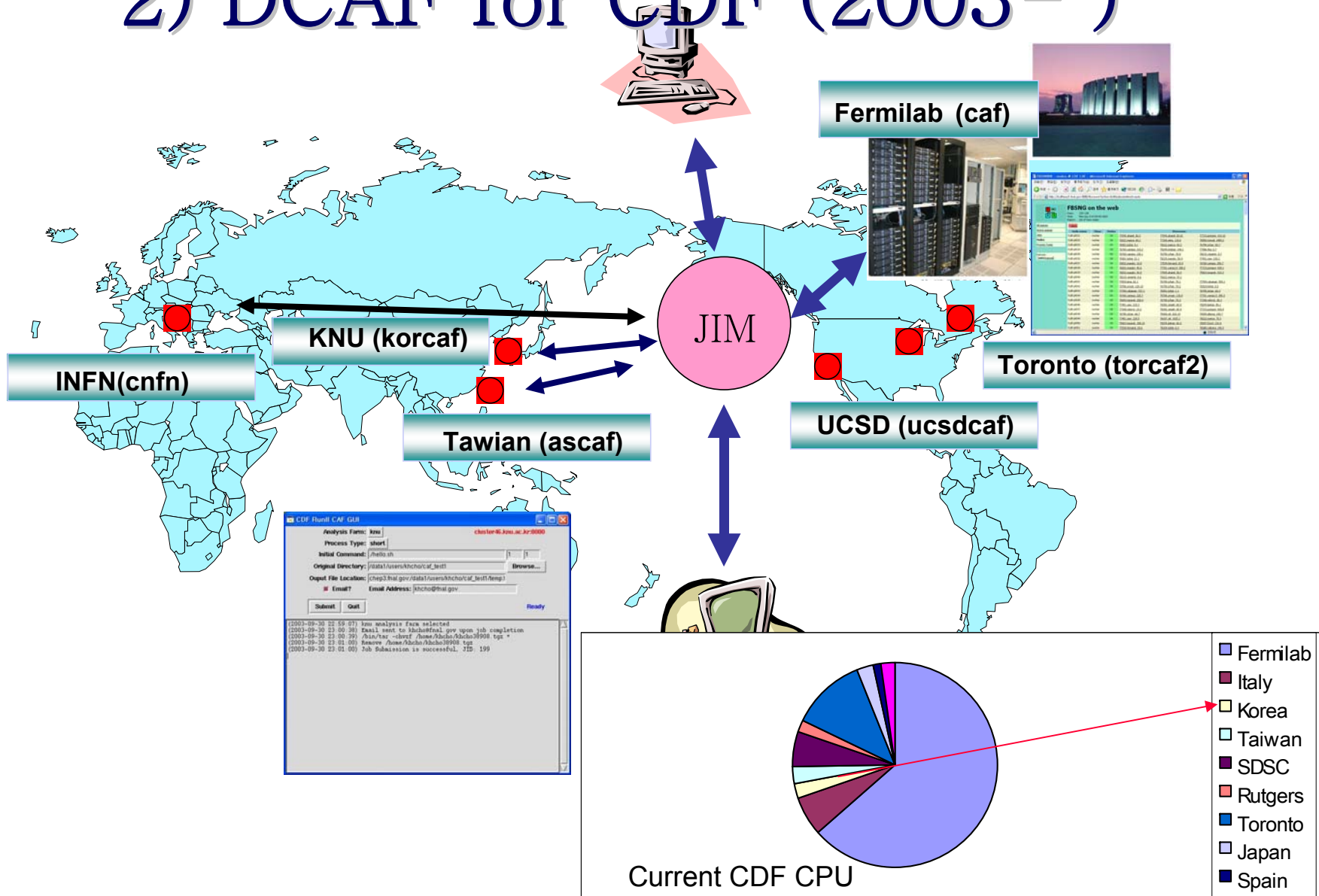

3) Belle

* KNU-KEK Belle Computing Farm

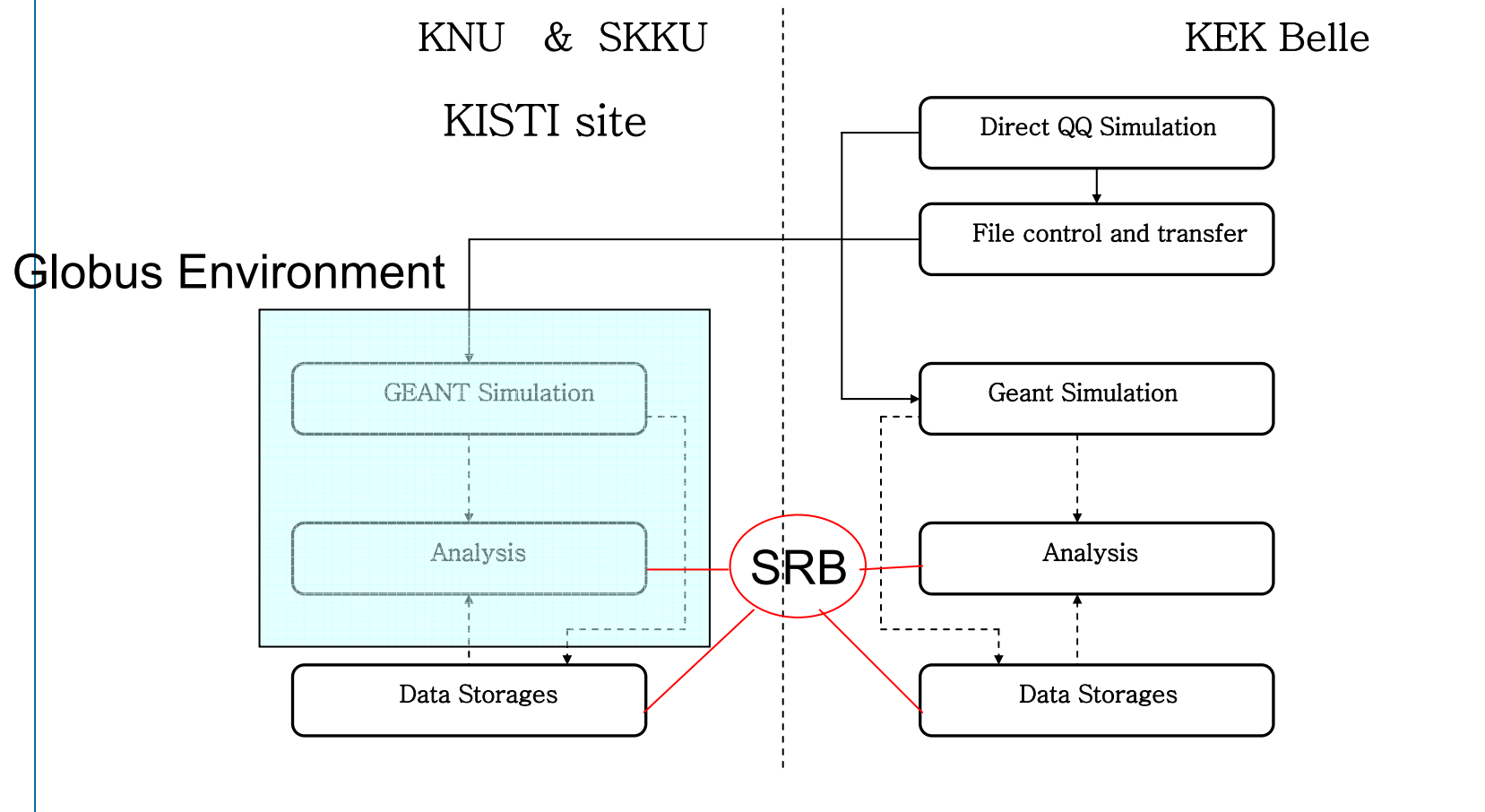

4) Grid3

GridCat

Ref. Bockjoo Kim

1 to 32 of 3

Service: C

Status

Wed Oct 6 15:34:12 EST 2004

인터넷

인터넷

CMS MC Simulation

CMKIN Viewer

QCD jet events - CMKIN job

```
[cho@cluster28 py_script]$ condor_q
-- Submitter: cluster28.knu.ac.kr : <155.230.20.58:32818> : cluster28.knu.ac.kr
ID   OWNER      SUBMITTED  RUN_TIME ST PRI SIZE CMD
42606.0  btev       7/16 13:47 10+22:13:55 R 0 5.3 data -t 313 12024
44323.0  uscms02    7/22 08:53 2+11:05:10 I 0 3.6 data
44395.0  ivdgl     7/22 09:15 4+22:56:23 R 0 5.3 data -t 159 11053
44405.0  lsc01     7/22 09:17 10+20:57:57 R 0 5.3 data -t 305 11041
44407.0  lsc01     7/22 09:17 8+13:20:50 R 0 5.3 data -t 307 11043
44424.0  ivdgl     7/22 09:18 4+11:40:04 R 0 5.3 data -t 265 12066
44427.0  ivdgl     7/22 09:19 5+05:03:58 R 0 5.3 data -t 268 12069
67641.0  ivdgl     9/11 06:35 2+14:08:24 R 0 0.5 sh -c uname -a; ls
82767.0  uscms02   10/14 03:01 0+10:13:09 R 0 3.6 data
82768.0  uscms02   10/14 03:01 0+10:12:49 R 0 3.6 data
82847.0  uscms02   10/14 08:25 0+04:35:08 R 0 3.5 data
82848.0  uscms02   10/14 08:29 0+04:44:55 R 0 3.5 data
82935.0  uscms02   10/14 12:57 0+00:12:02 R 0 0.0 data
82937.0  uscms02   10/14 13:02 0+00:11:18 R 0 0.0 data
82938.0  uscms02   10/14 13:07 0+00:06:52 R 0 0.0 data
82941.0  uscms02   10/14 13:12 0+00:00:23 I 0 0.0 data
82942.0  uscms02   10/14 13:12 0+00:01:24 R 0 0.0 data
82943.0  cho       10/14 13:14 0+00:00:15 R 0 2.3 condor_dagman -f -
82945.0  cho       10/14 13:14 0+00:00:00 I 0 0.0 stage-in-Play_USMO
82944.0  uscms02   10/14 13:14 0+00:00:00 I 0 0.0 data
```

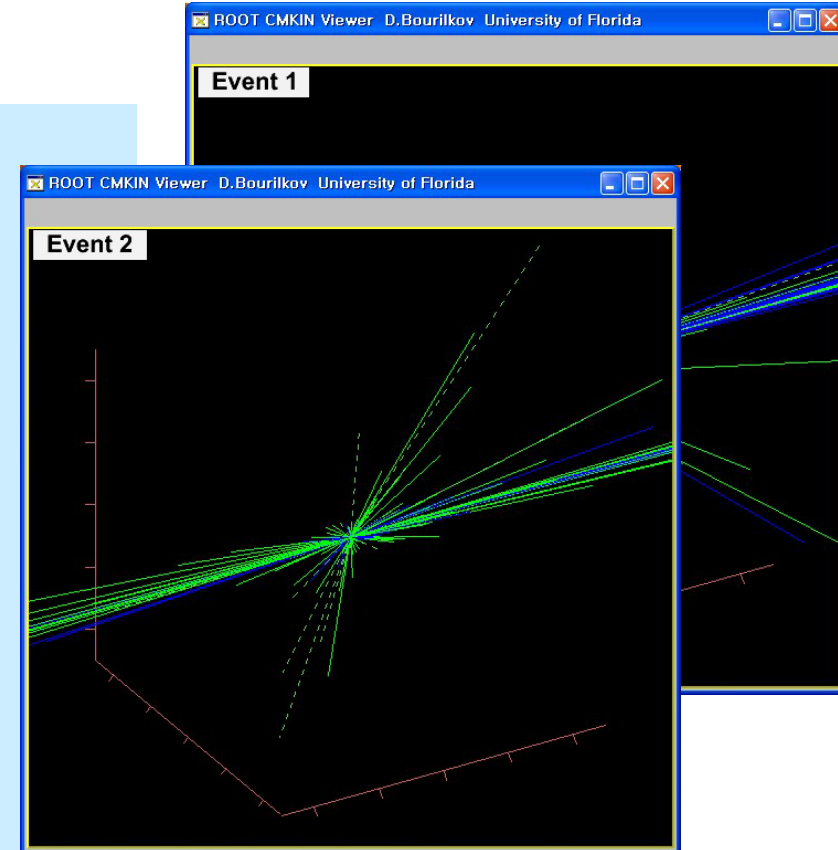

QCD jet events

⇒ We support 30 institutes for Physics, Astronomy, Biology and Computer Science.

5) LCG2 Farm

- LCG_KNU Farm

Node	Server
CE	cluster50.knu.ac.kr
WN	cluster69.knu.ac.kr
UI	cluster3.knu.ac.kr
BDII	cluster3.knu.ac.kr
RB	cluster3.knu.ac.kr

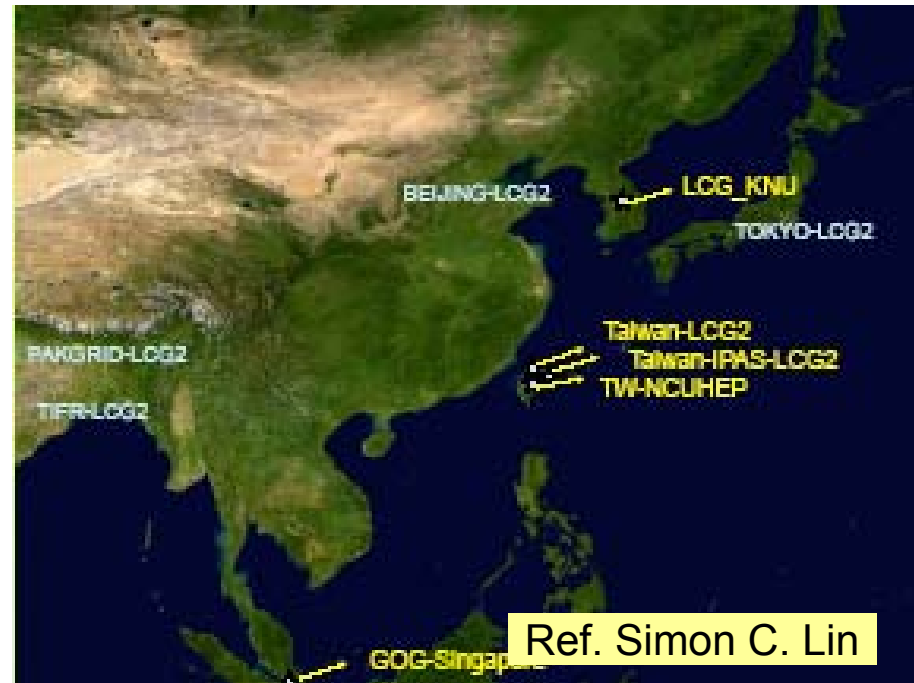

LCG Map in Asia

6) Dual operation system

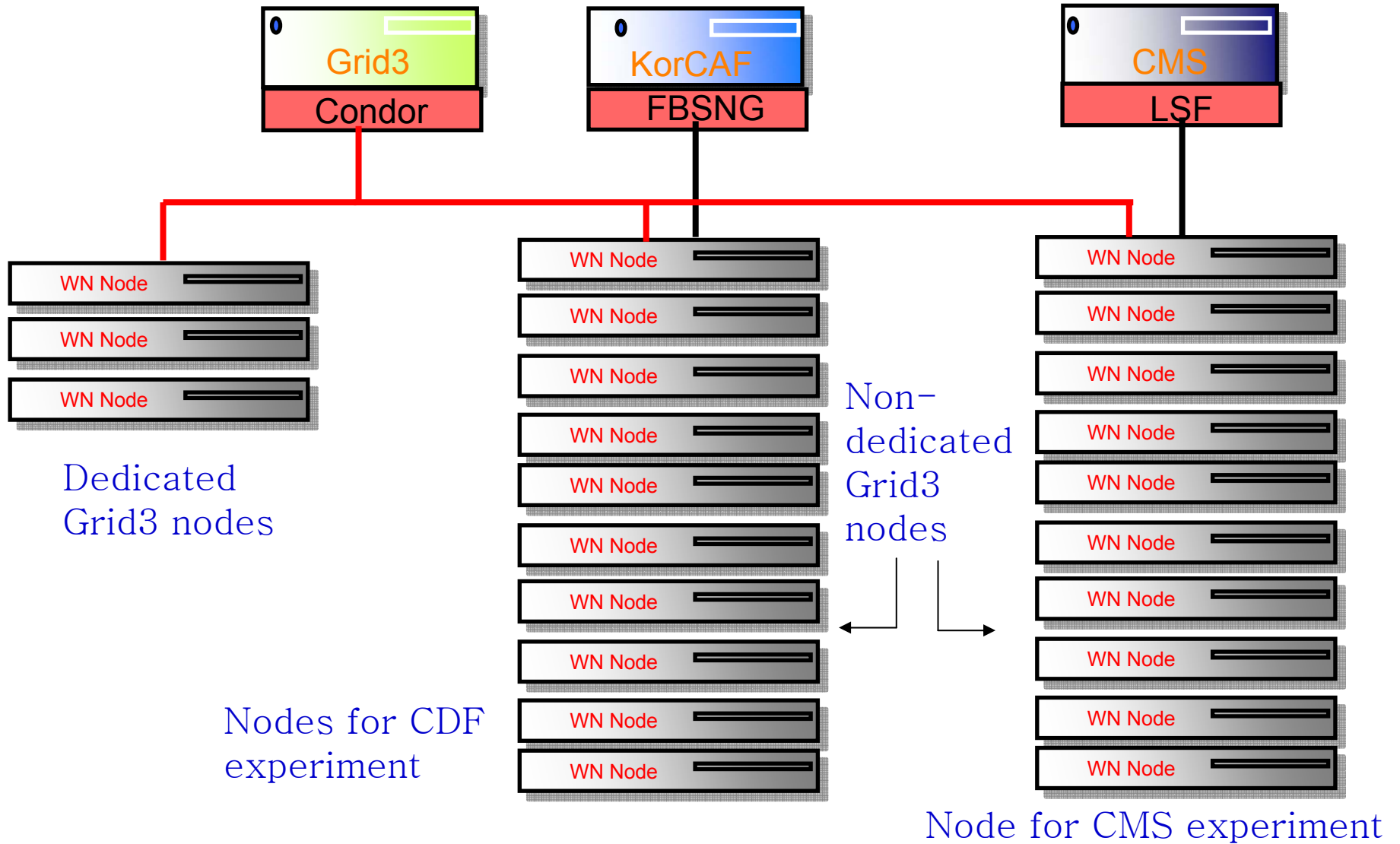

Plan for interoperability @ KNU

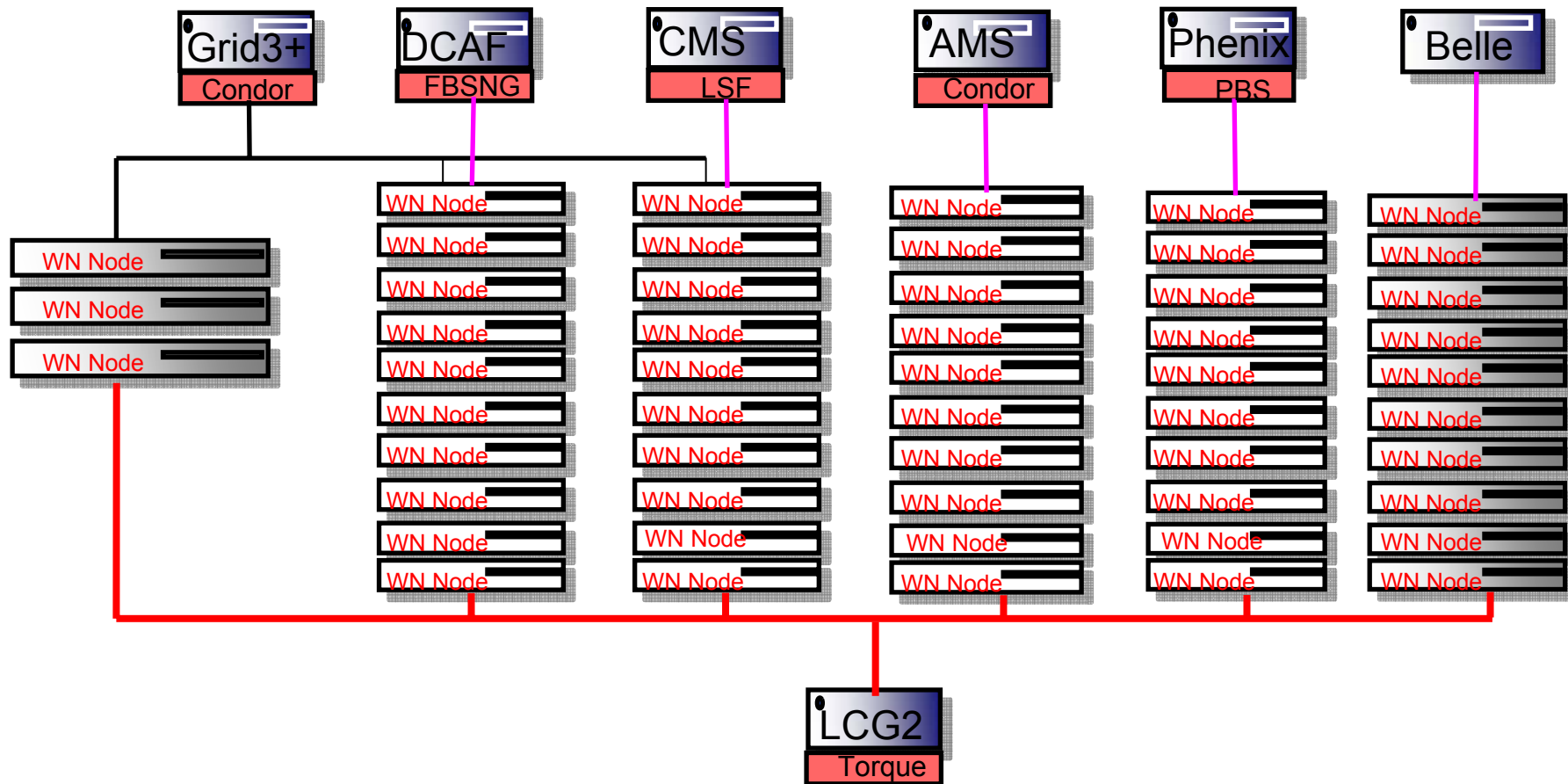

Activities in Korea

- International HEP Data Grid Workshop
 - 3 times @ KNU (2002-2004)
 - This workshop (2005)
- Demos at SC2002, SC2003, SC2004, GGF13, GFK
 - SAMGrid, Bandwidth Challenge, DCAF, Belle Grid, Grid3
- Constructing KR-CHEP CA, KR-CHEP VO

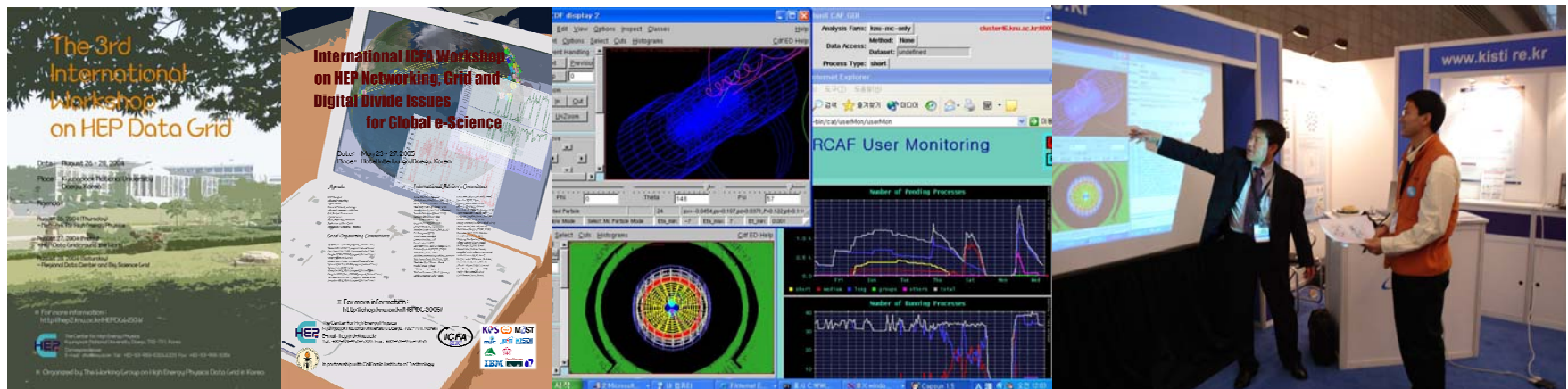



Korean Group

Future Plan for Grid

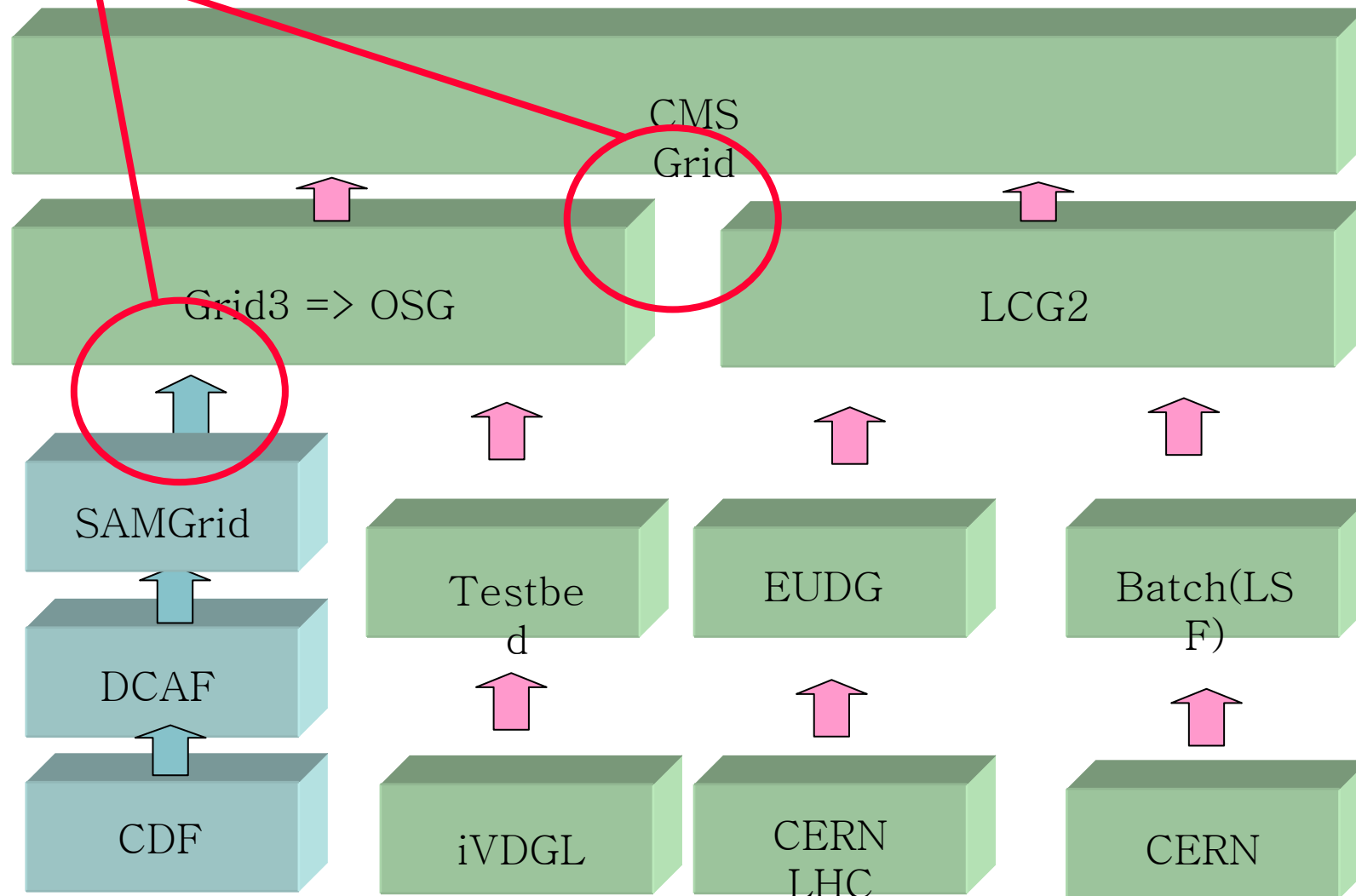

Summary

- e-Science is a great concept for High Energy Physics.
- Grid meets e-Science perfectly for resource sharing and virtualization.
- e-Science High Energy Physics should be progressed.



Thank you.

Please enjoy Daegu.