

Superconducting Magnet Technology for Particle Accelerators and Detectors

T. M. Taylor, CERN

Summer Student Lecture, 2006

Aim of this lecture

- **To give an introduction** to superconducting magnets for particle accelerators and detectors, to **explain the vocabulary** and **describe the basic technology** of modern superconducting magnets, and to **explore the limits** of the technology

The field developed strongly from the 1960s, and development has continued mainly by incorporating advances in technology

NB: Besides their importance for HEP, superconducting magnets have many applications in science, engineering and medicine

- **Perhaps some will find this field of study provides an interesting alternative challenge...**

Superconductivity in high energy particle accelerator magnets

- 1981 **CERN: ISR**, SC low-beta insertion to increase luminosity
- 1985 **Fermilab: Tevatron**, 2 x 800 GeV *superconducting p-pbar collider*
- 1989 **CERN** starts **LEP** - the world's highest energy e⁻e⁺ collider
- 1991 **HERA** at **DESY** - the first major facility for colliding for protons (SC ring) with electrons or positrons
- 1999 **RHIC** at **BNL** - the major facility for colliding ions
- 2007 **CERN** will start the **LHC** - the world's highest energy proton-proton collider (superconducting, twin-bore magnets)

Superconductivity in high energy physics detector magnets

Not an exhaustive list!

- 1969 CERN – BEBC, Big European Bubble Chamber (solenoid)
- 1972 CERN – Omega magnet (large aperture dipole)
- 1977 CERN/ISR – Solenoid
- 1978 DESY – CELLO (solenoid)
- 1983 SLAC/PEP4 – TPC solenoid
- 1985 KEK/TRISTAN – TOPAZ, VENUS (solenoids)
- 1988 CERN/LEP – ALEPH, DELPHI (solenoids)
- 1990 DESY/HERA – ZEUS (solenoid)
- 1997 SLAC – BABAR (solenoid)
- 2004 KEK – BESS-Polar (ultra-thin solenoid)
- 2007 CERN/LHC – CMS (solenoid), ATLAS (Toroids, solenoid)

Bibliography I

Basic Superconductivity:

- M. Tinkham, *Superconductivity*, Gordon & Breach
- A.C. Rose-Innes, E.H. Rhoderick, *Introduction to Superconductivity*, Pergamon Press
- W. Buckel, *Superconductivity, Fundamental and Applications*, VCH
- J. Evetts (ed.) *Coincise Encyclopedia of Magnetic and Superconducting Materials*, Pergamon Press
- H.W. Weber *High Tc Superconductivity*, Plenum Press
- G. Vidali, *Superconductivity: the next revolution*, Cambridge University Press

Bibliography II

Applied Superconductivity

- M.N. Wilson, *Superconducting Magnets*, Clarendon Press Oxford
- K.-H. Mess, P. Schmüser, S. Wolff, *Superconducting Accelerator Magnets*, World Scientific
- E.W. Collings, *Applied Superconductivity*, Plenum Press
- B. Seeber (editor), *Handbook of Applied Superconductivity*, IoP Publishing
- L. Dresner, *Stability of Superconductors*, Plenum Publ. Corp.
- Y. Iwasa, *Case Studies in Superconducting Magnets*, Plenum Publ. Corp.

Bibliography III

CERN Academic Training

- 1999 : P. Lebrun - Superfluid Helium
- 2000 : L. Rossi - Superconducting Magnets
- 2002 : D. Larbalestier - Superconducting Materials
- 2003 : O. Bruning et al. - LHC Technologies
- 2006 : M. Wilson – Pulsed Superconducting Magnets

Relevant CERN Accelerator Schools (CAS)

- 1988: Superconductivity in Particle Accelerators, CERN 89-04
- 1992: Magnetic Measurement and Alignment, CERN 92-05
- 1995: Superconductivity in Particle Accelerators, CERN 96-03
- 2002: Superconductivity and Cryogenics for Accelerators and Detectors, CERN-2004-008

Thanks

Much of the information in this lecture has come from colleagues - of course !

In particular I wish to acknowledge significant input from Martin Wilson, Lucio Rossi, Akira Yamamoto, Alain Herve and Herman ten Kate. Much of the visual data has been gleaned from their work. Thanks!

Accelerators - beams of particles

- Particles = Electrons, protons, ions ... photons...
- We would like beams to be *intense*
(*how to keep them dense?*)
- and to be *energetic*
(*how to give them energy?*)

The study of particle and photon beams and their manipulation has led to advances in **magnet science**. It has evolved from classical mechanics, electromagnetism, and thermodynamics into a rich field of its own.

Basic knowledge for the study of superconducting magnets

- **Classical theory of electromagnetism**
- **Properties of practical superconductors**
- **Optical concepts**
- **Electrical engineering**
- **Mechanical engineering**
- **Cryogenic engineering**

Why do we need magnets?

They are so heavy and expensive !

Basic concept 1 – why we need magnets

- Lorentz force

The force F acting on charge q in fields E and B

$$F = q(E + v \times B)$$

Units	Force	F	newton
	Electric field	E	V/m
	Magnetic field	B	tesla
	Velocity	v	m/s

Accelerators – control of beams of particles

Detectors – identification of particles by measuring tracks

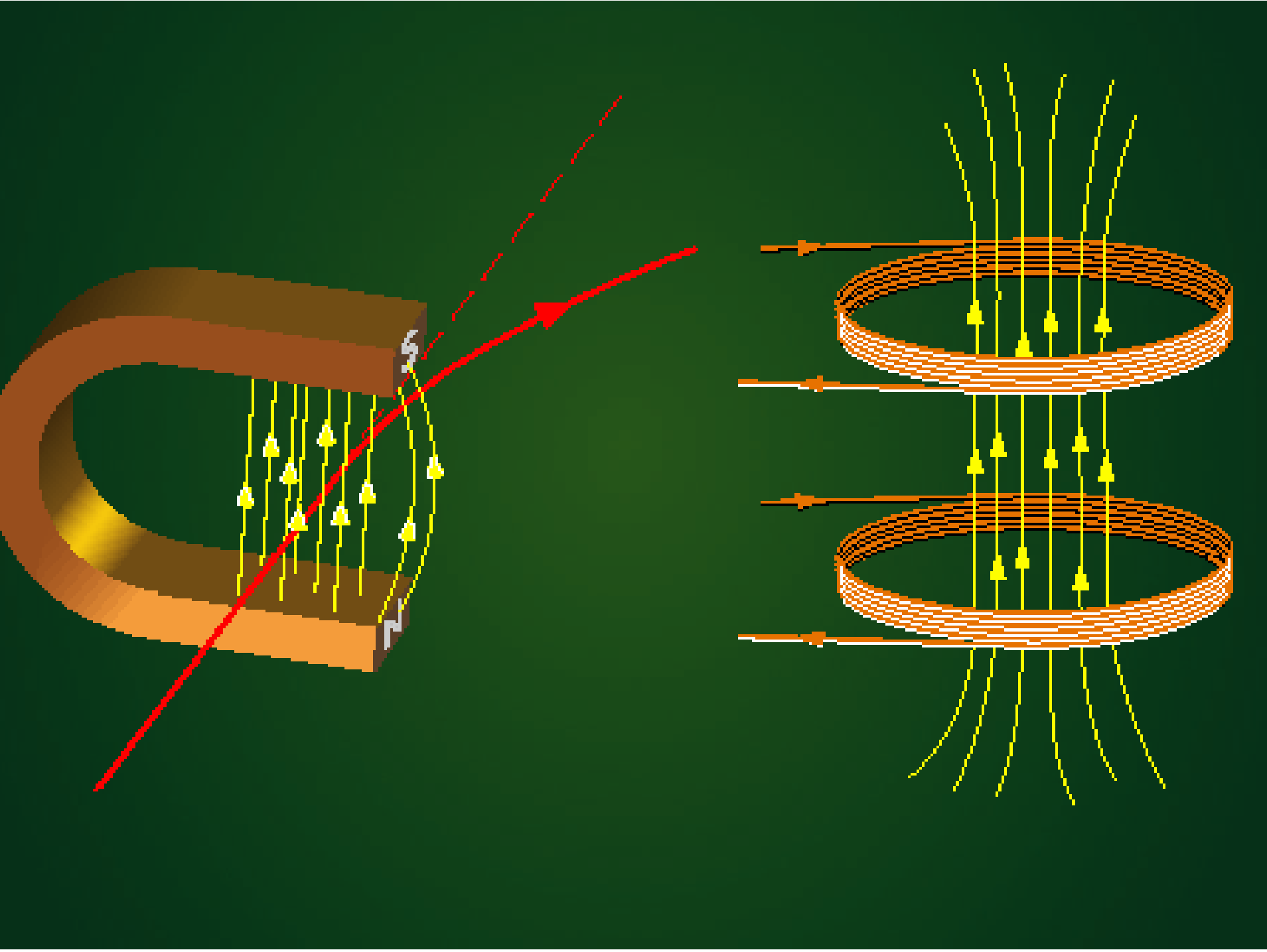

Basic concept 2 – how to get the field

- Magnetic induction

The magnetic induction dB produced by current element Jdl is

$$dB = (\mu_0/4\pi)Jdl \times r_1/r^2$$

where $\mu_0 = 4\pi \times 10^{-7}$

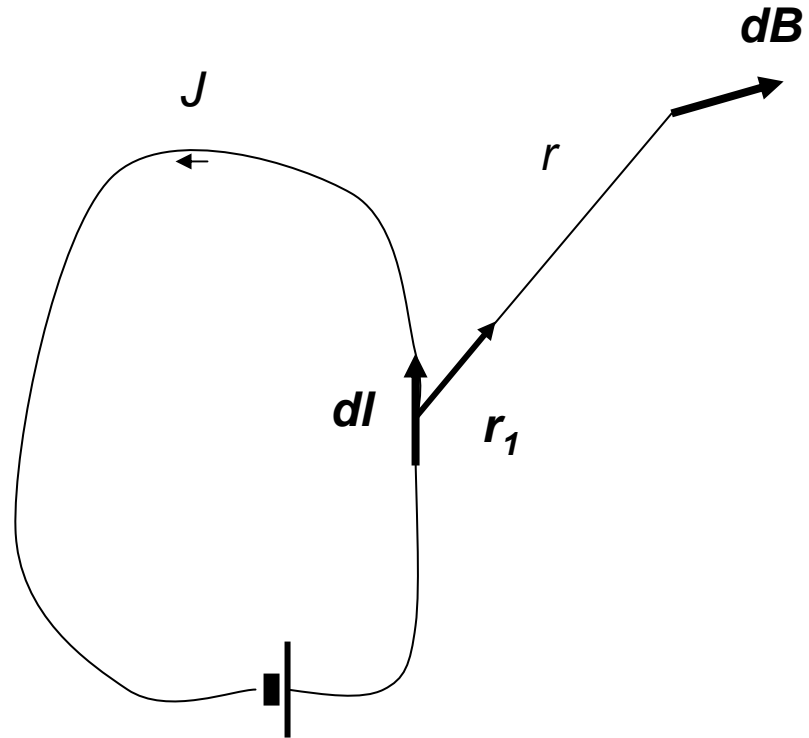

Basic concept 3 – the downside

- Lorentz force (again!)

The force dF acting on an element of conductor dl carrying current J in a magnetic field B

$$dF = Jdl \times B$$

Units	Force	F	newton
	Current	J	ampere
	Magnetic field	B	tesla

In order to produce the field, the current has to be large – the resulting force is important  major problem

Circular motion of a charged particle in a constant magnetic field

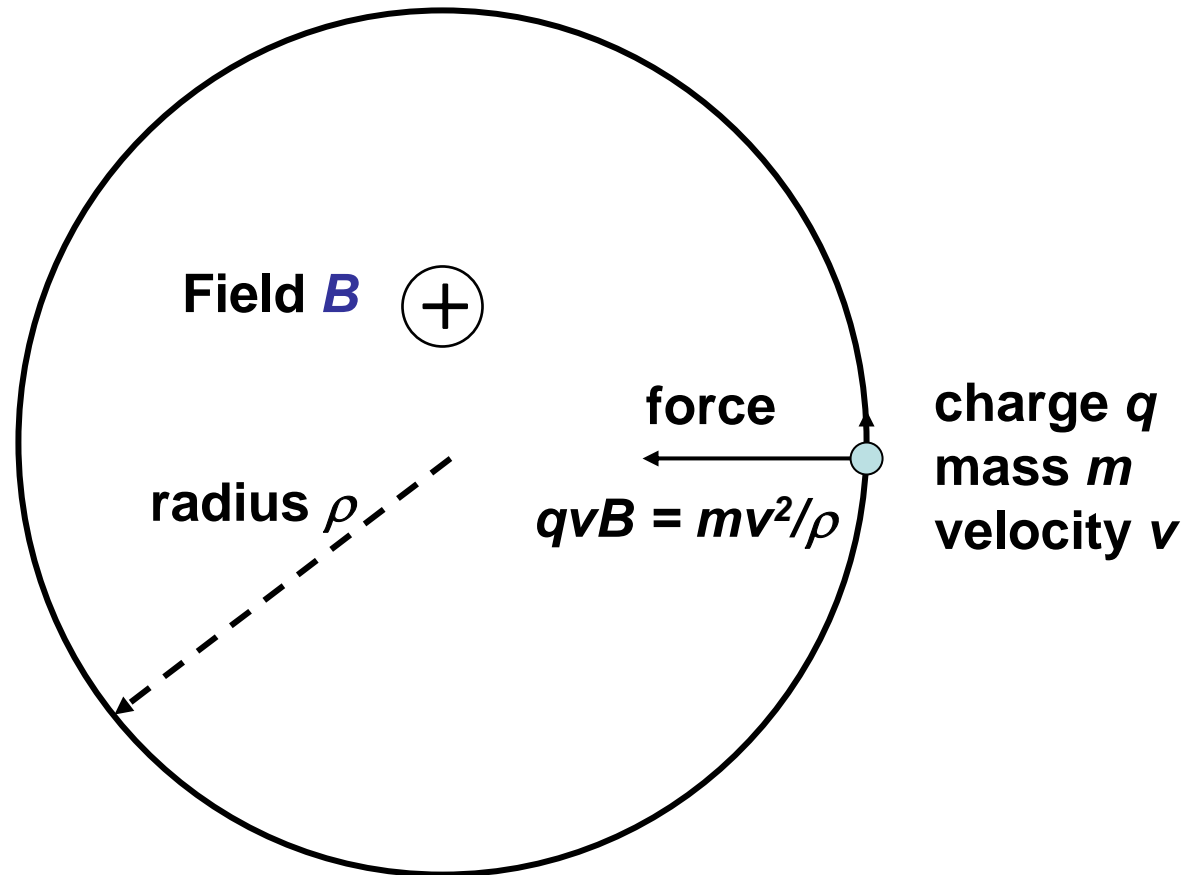

Synchrotron acceleration

*Accelerating field
generated by r.f. sources*

*beam contained in narrow
channel, by ramping B*

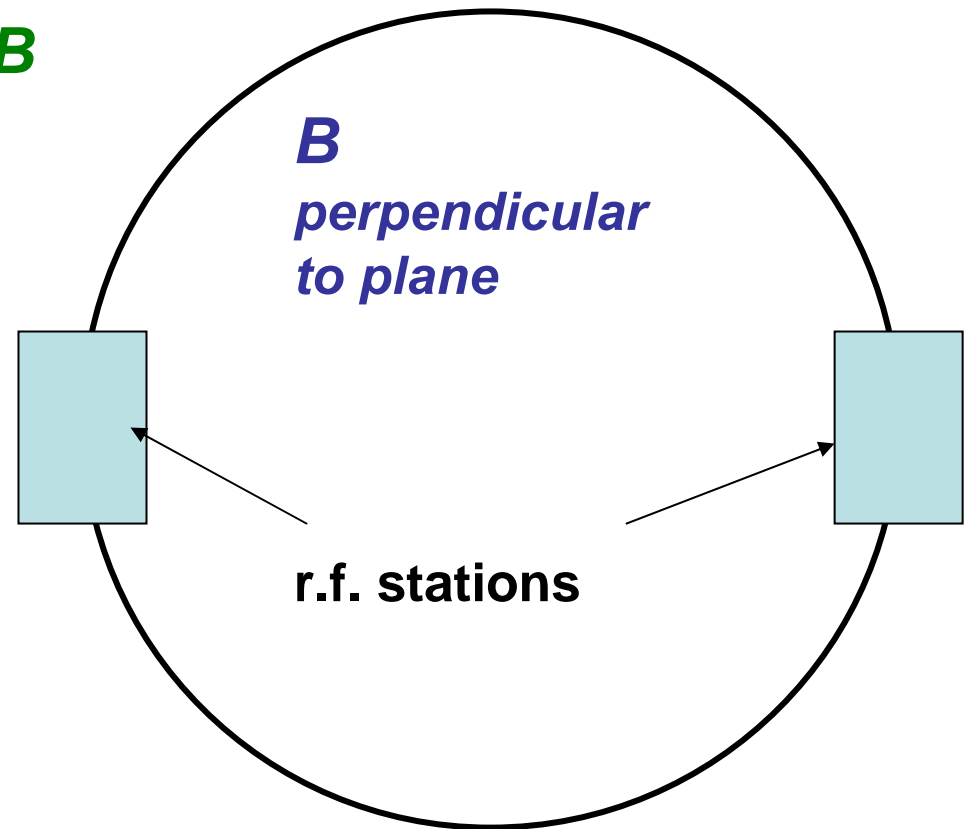

Transverse motion

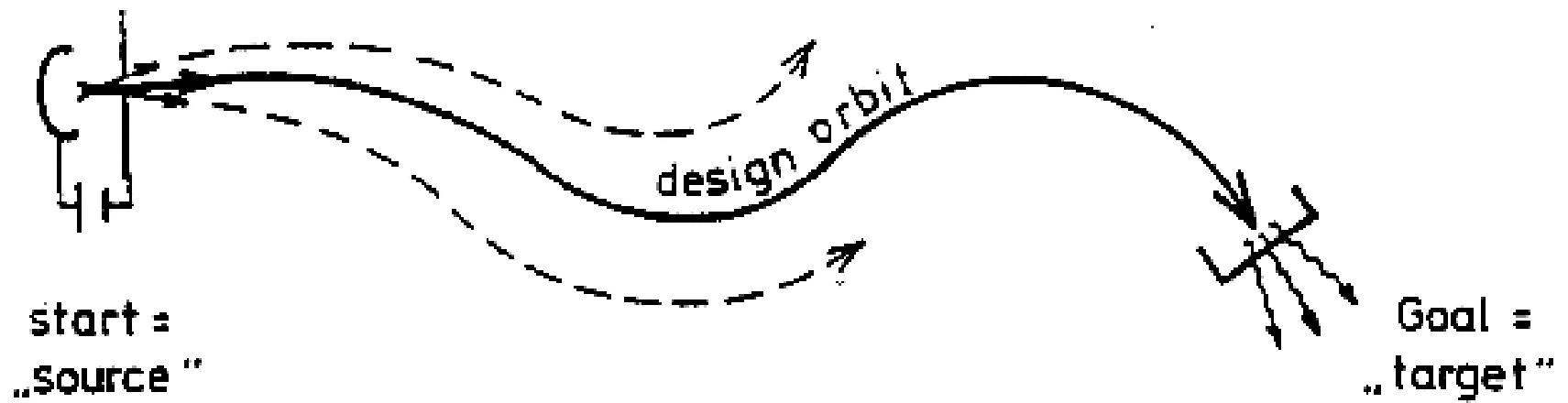

*We need to **guide** the beam and to **focus** it*

Focusing

The particles in the beam will not all have exactly the same energy and will not all be traveling in precisely the same direction. And there will be interactions with gas remaining in the vacuum. *So how is the beam preserved from diverging?*

It's surprisingly easy!

Lorentz => Particle beams are deflected by transverse electric and magnetic fields

$$\mathbf{E}\text{-field} \Rightarrow F_t = q\mathbf{E}_t$$

$$\mathbf{B}\text{-field} \Rightarrow F_t = qv\mathbf{B}_t$$

(subscript t refers to components transverse to the beam trajectory)

NB: only initial stages can use the **E-field** effectively

Examples: electrostatic focusing – **Pierce gun**
simple magnetic focusing – **Solenoid**

Gun (Pierce)

Solenoid focusing

Electron
producing
system

focusing
system

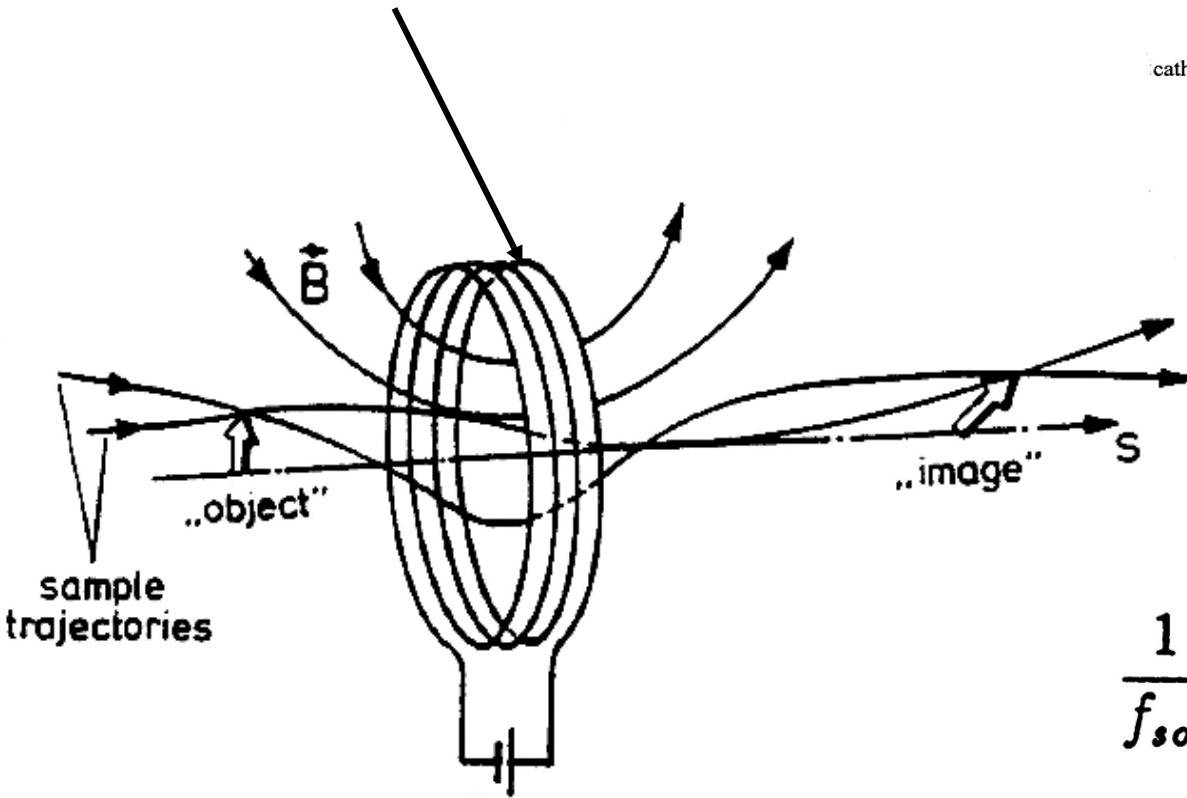
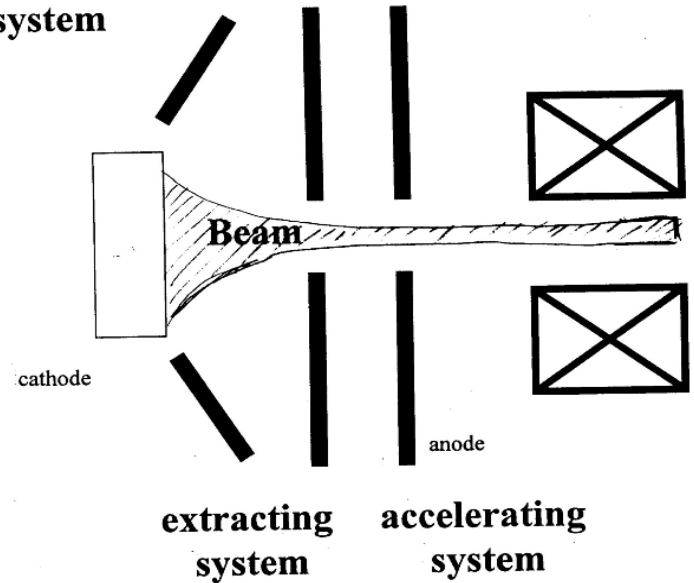

$$\frac{1}{f_{sol}} = \int \left(\frac{eB_s}{2p} \right)^2 ds$$

Weak focusing of a beam of charged particles

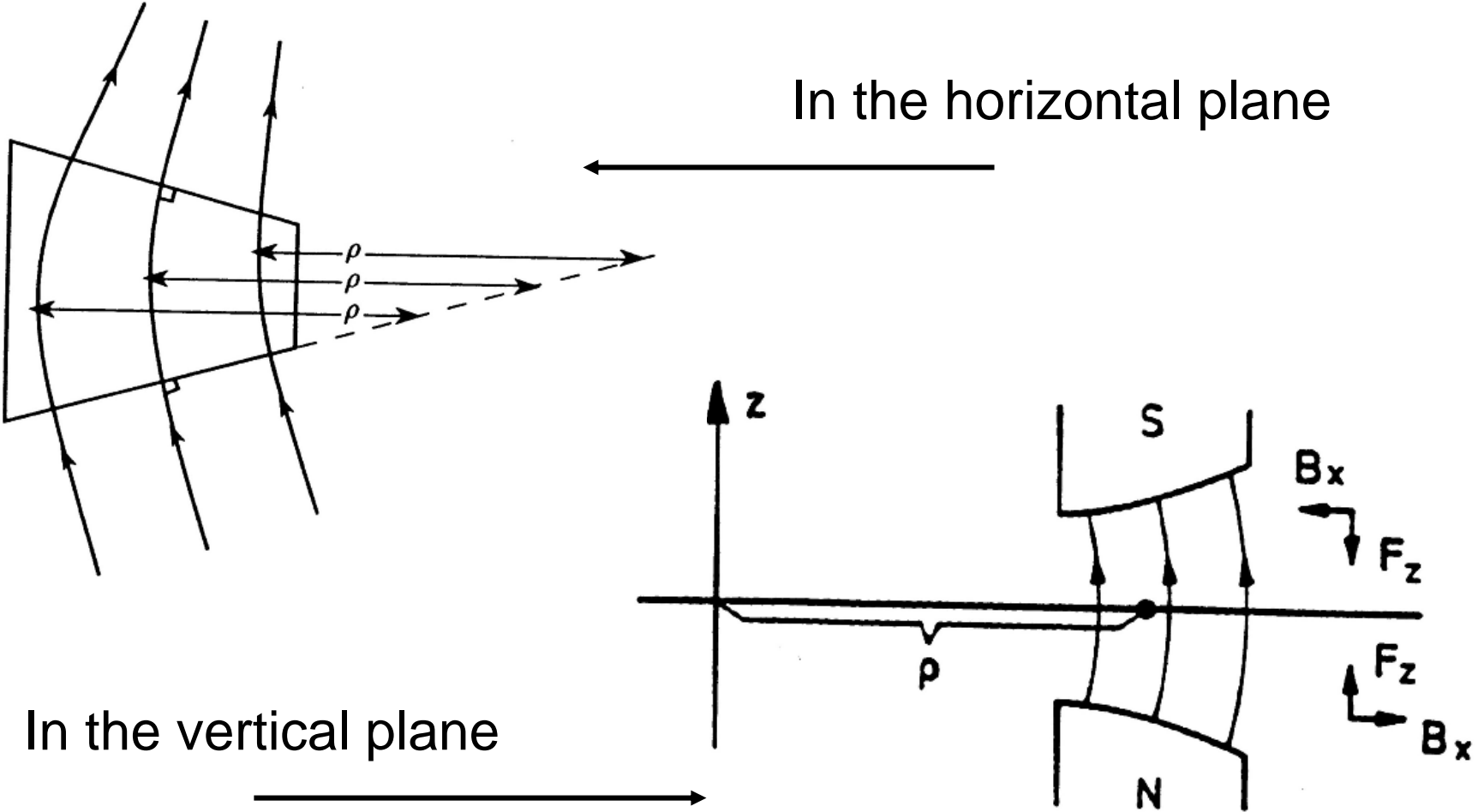

Weak focusing in cyclotron

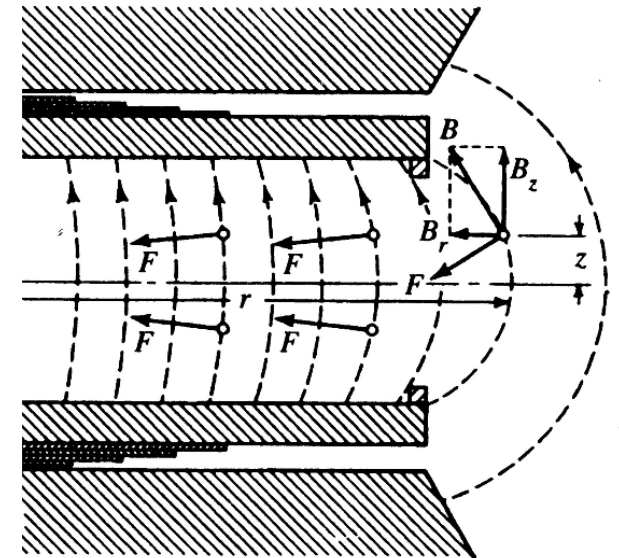
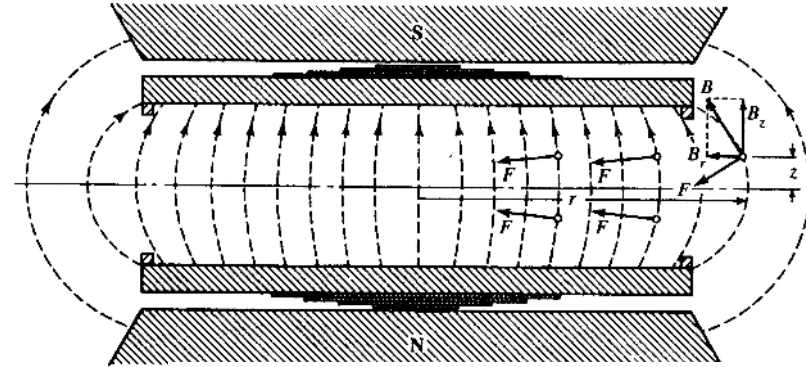
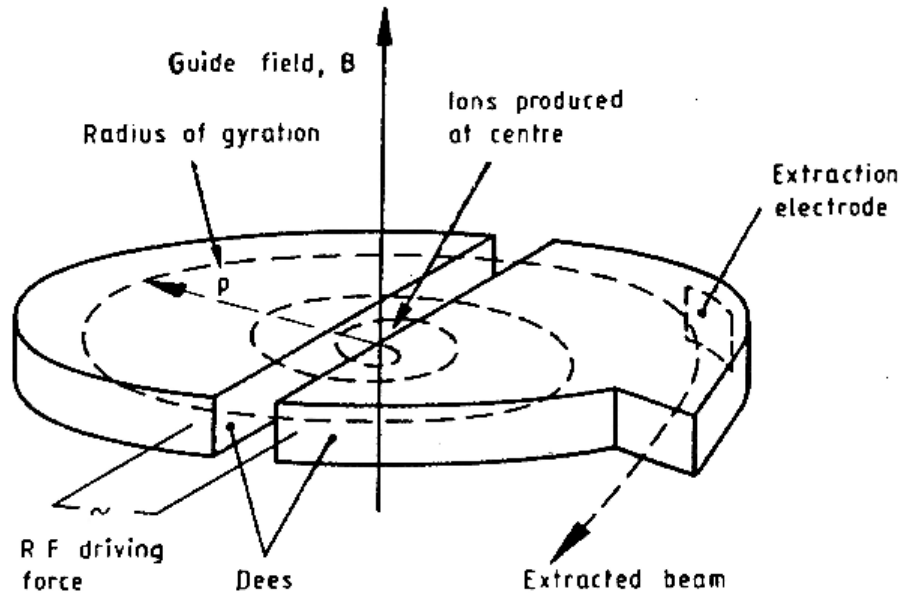

Magnet parameters for accelerators

- Dipole – Magnetic rigidity $B\rho$

$$F = qvB \Rightarrow B\rho = mv/q = p/q$$

So, for $q = e$ (electronic charge), $B\rho = 3.3356p$ [T.m]
(momentum p in GeV/c)

- Quadrupole – Gradient k

Field gradient $K \equiv dB_z/dx$ [T/m]

Focusing quadrupole QF focuses horizontally

Defocusing quadrupole QD focuses vertically

- FODO Cell

Alternate focusing and defocusing elements with a non-focusing drift space between them  Net focusing

FODO cell

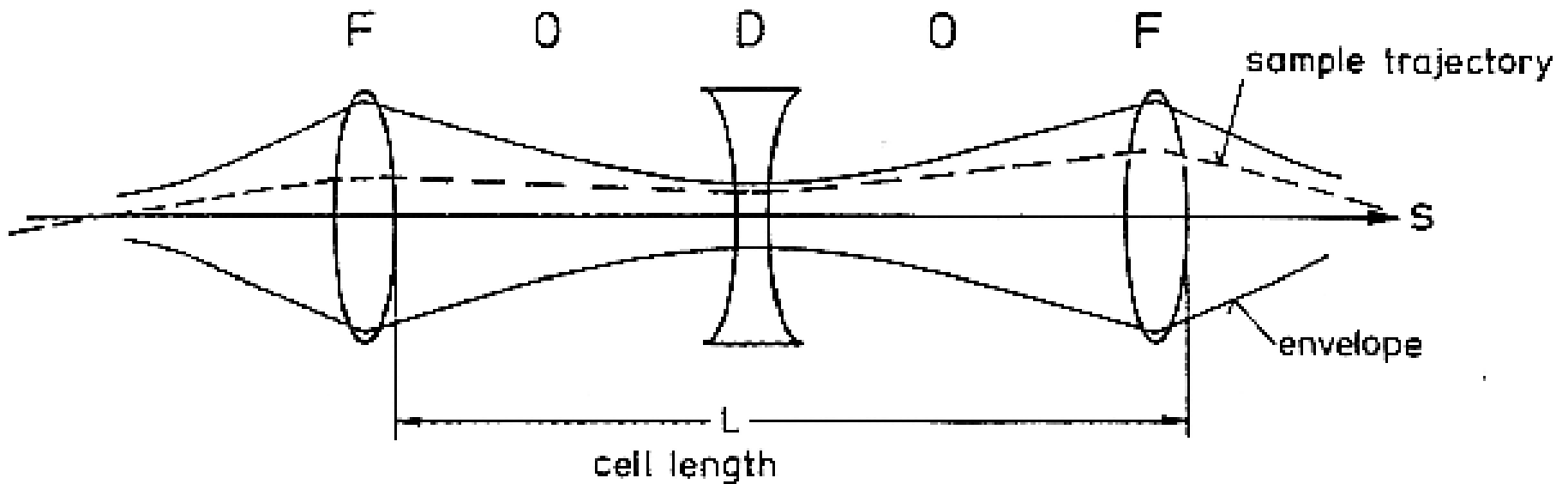

Strong focusing

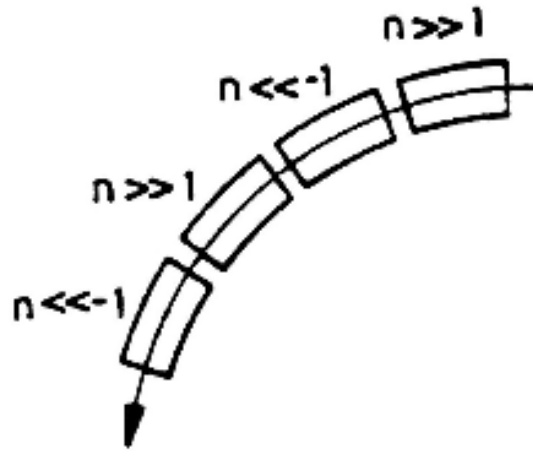

Dipole + quadrupole fields -
Combined function

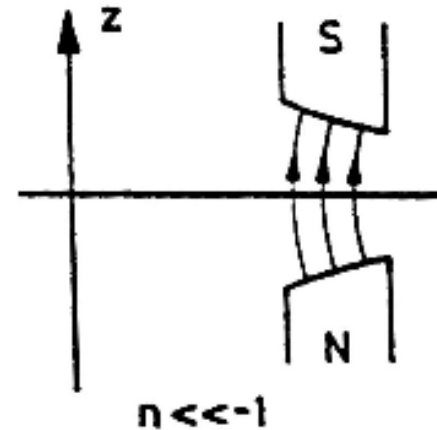
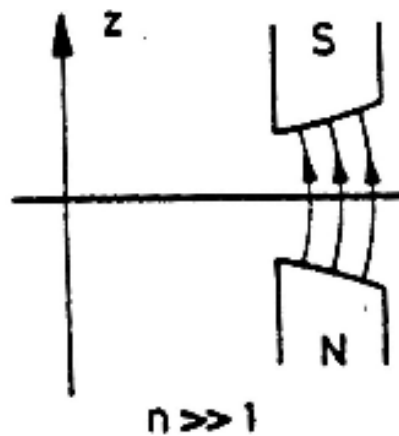

Quadrupole magnet

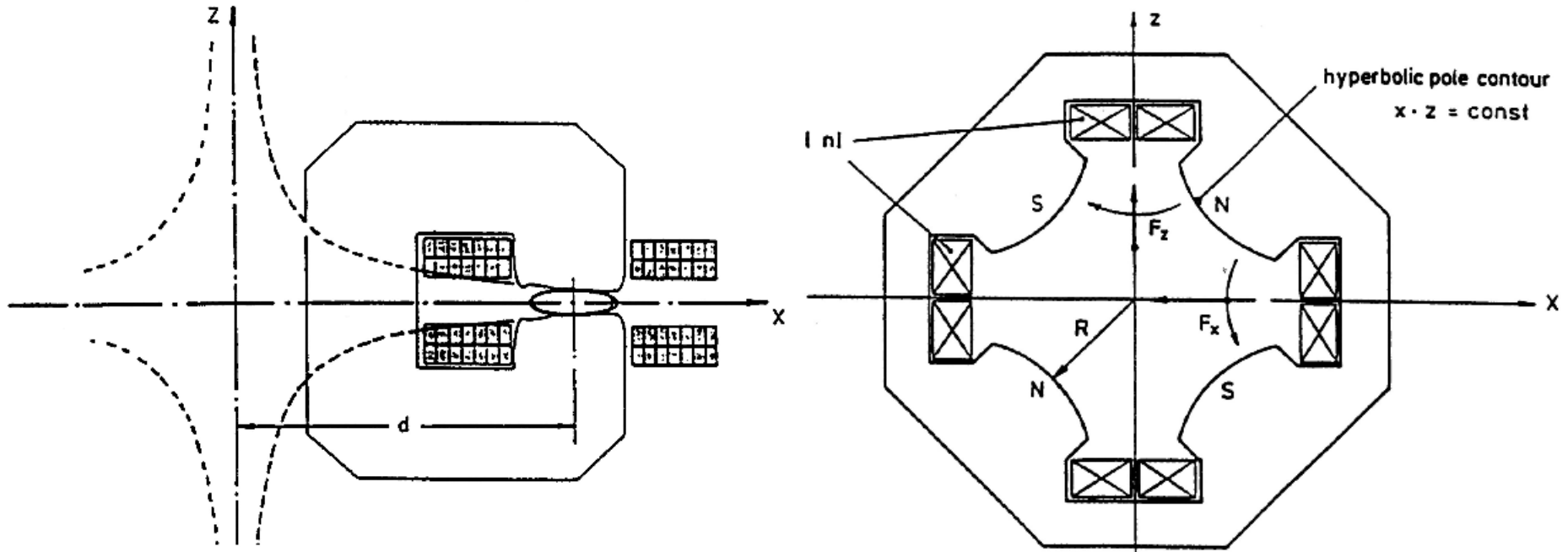

Dipole + quadrupole =
Combined function magnet

But why bother with superconductivity ?

- **No Ohm's law**
 - ⇒ no significant power consumption (*but requires power for refrigeration...*)
 - ⇒ lower power bills
- ampere turns are cheap, need less iron
 - ⇒ higher magnetic fields
 - ⇒ higher energies and smaller rings
 - ⇒ reduced capital cost
- high current density
 - ⇒ compact windings
 - ⇒ high gradients
 - ⇒ higher luminosity

BUT

- SC magnets difficult to make and run (there's not much safety margin!)
- They need **refrigeration**, **insulation**, **protection** and **cryogenic pipework**

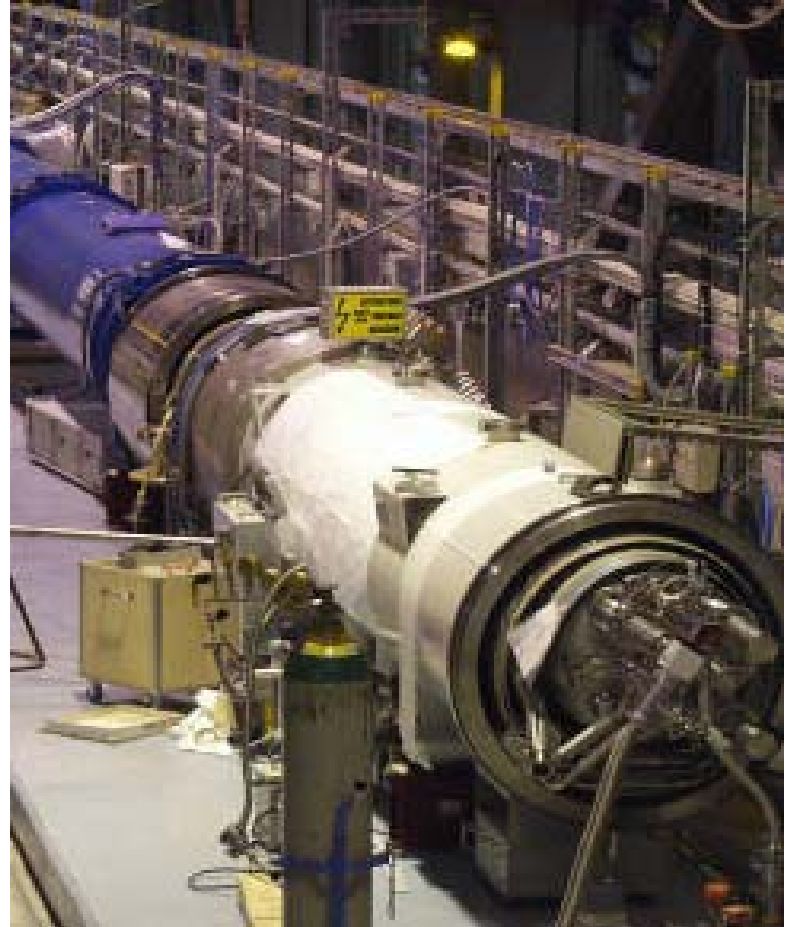

The real reason: it lets us do things we can't do without it !

We would like high fields, but...

- **Iron dominated magnets limited by iron saturation at 2 T !**
- **Permanent magnets practically limited in the range 1-2 T**
- **Copper (or Al) dominated magnets 50-100 T but for ms !!!**

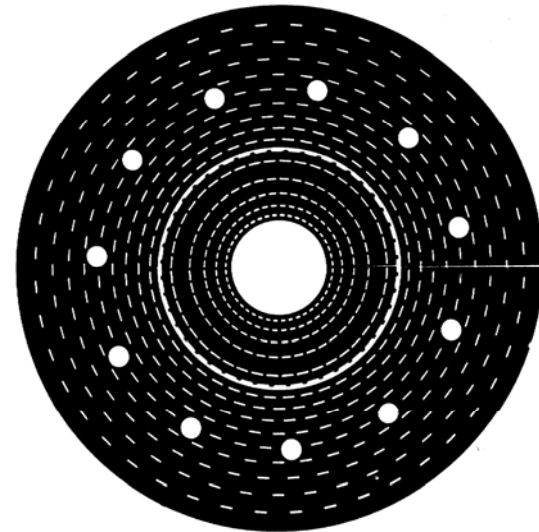

Disk of Bitter magnet;
pulsed cryogenic magnet
for 40 T - 5 ms

The critical surface for niobium titanium

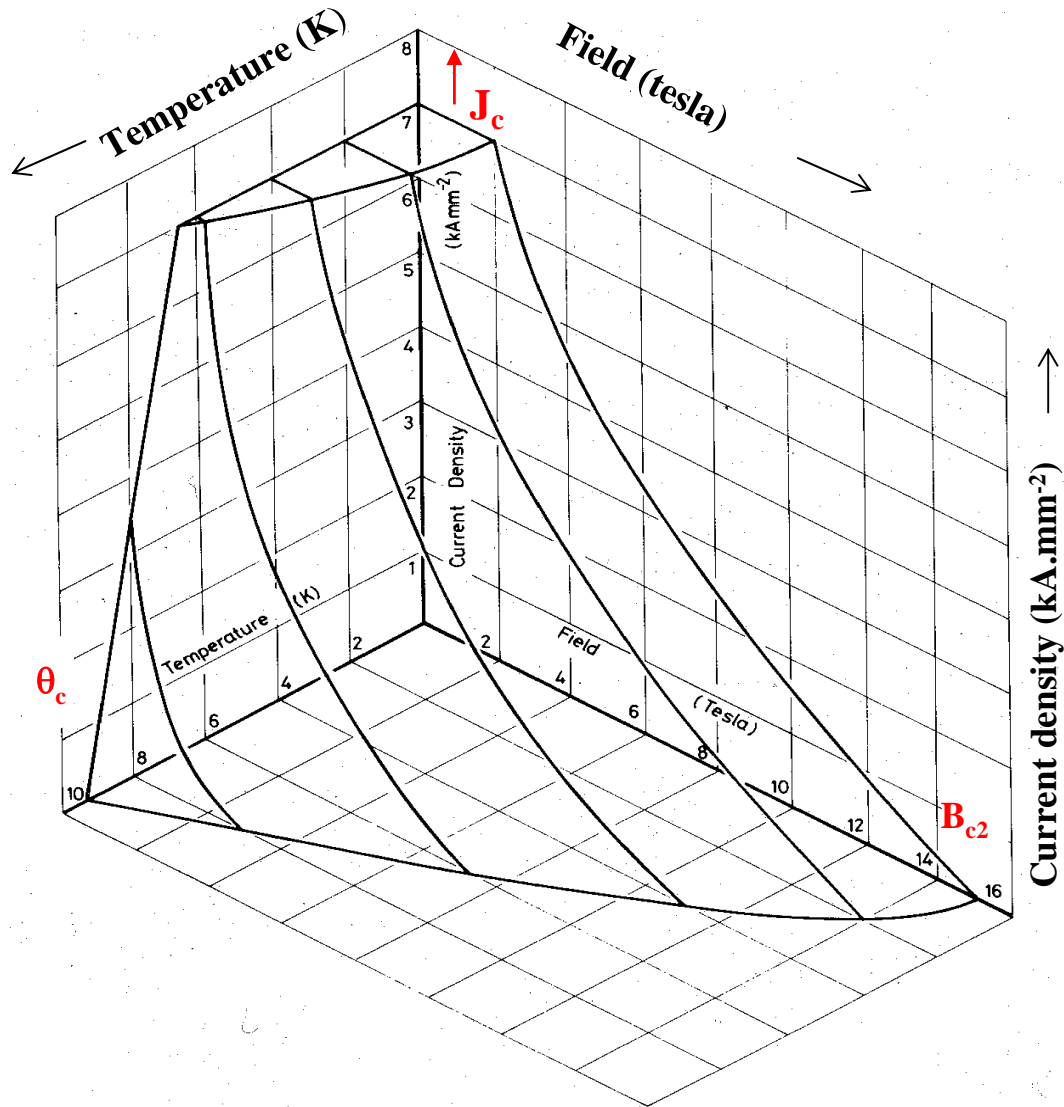

- Niobium titanium **Nb-Ti** is standard 'work horse' of the SC magnet business
- **Nb-Ti** is a ductile alloy
- Superconductivity below the surface, resistance above it
- Upper critical field B_{c2} (at zero temp. and current)
Critical temperature θ_c (at zero field and current)
depend on the alloy
- Critical current density
 $J_c(B, \theta)$
depends on processing

Critical Field of various superconductors

- NB: A superconductor is not a simple perfect conductor
 J_{sc} is limited by magnetic field and operating temperature
- The first SC materials (pure elements) had B_c of 10-100 mT
In the 1950-60s alloys were discovered with B_c of 10-20 T
- Ceramic HTS have B_c 100 T
MgB₂ has B_c around 15 T

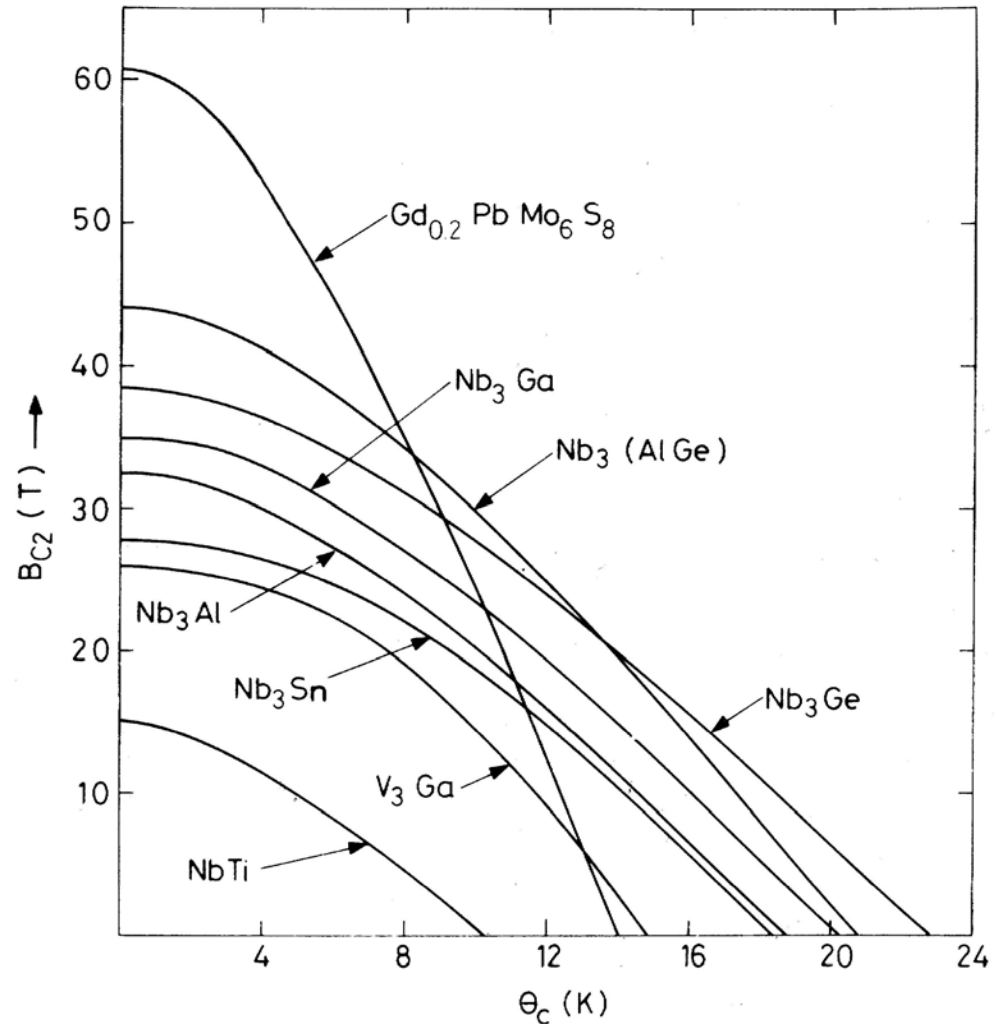

Superconducting vs. normal magnets

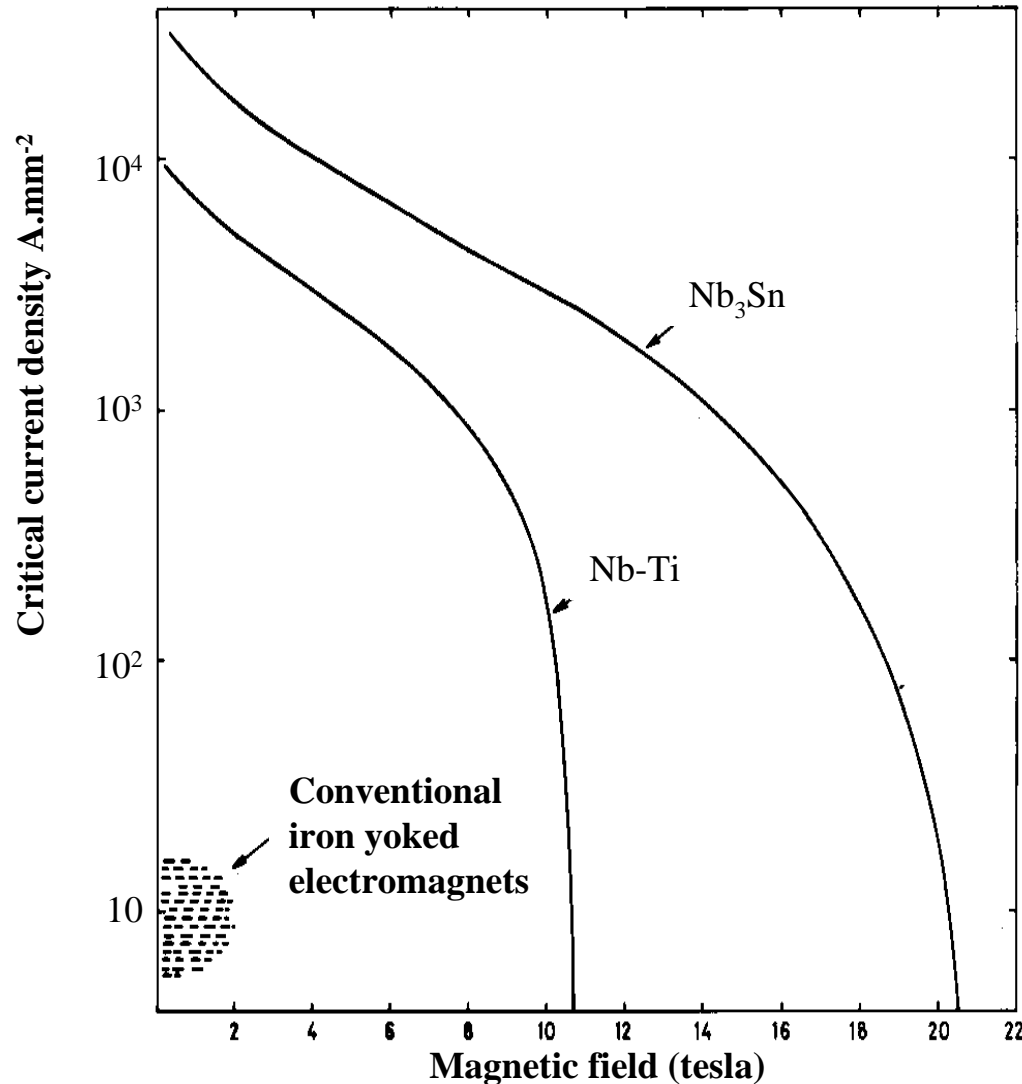

- Magnets usually work in boiling liquid helium, where the critical is represented by a curve of current versus field at 4.2K
- Niobium tin **Nb₃Sn** has a much higher performance in terms of critical current field and temperature than **Nb-Ti**

but it is brittle intermetallic compound with poor mechanical properties

However

- **The field and current density of both superconductors are much better than those of conventional electromagnets**

Manufacture of Nb-Ti

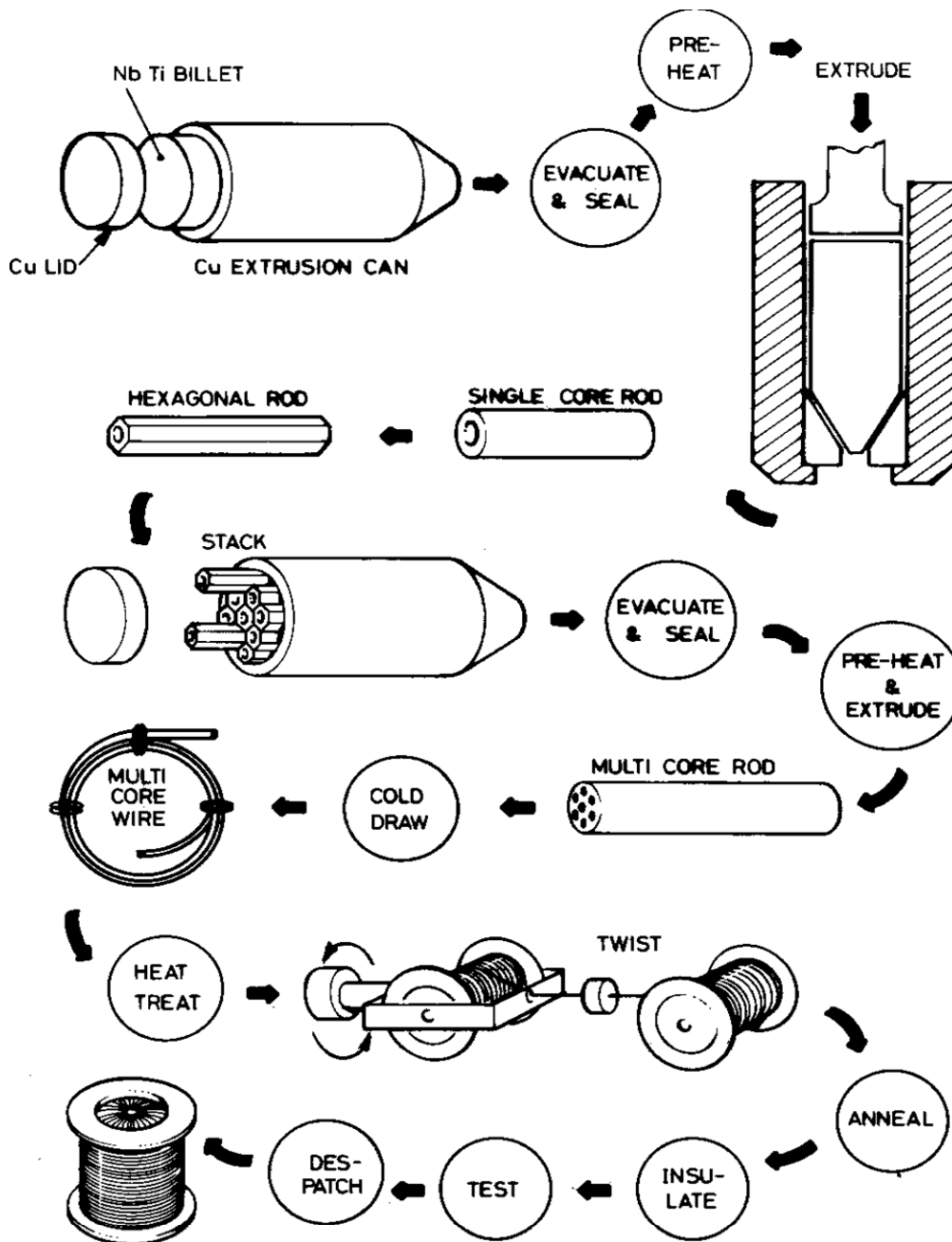

- vacuum melting of NbTi billets
- hot extrusion of the copper NbTi composite
- sequence of cold drawing and intermediate heat treatments to precipitate flux pinning centres
- for very fine filaments, we must avoid the formation of brittle CuTi intermetallic compounds during heat treatment
(this is done by enclosing the Nb-Ti in a thin Nb shell)
- twisting (to avoid coupling)

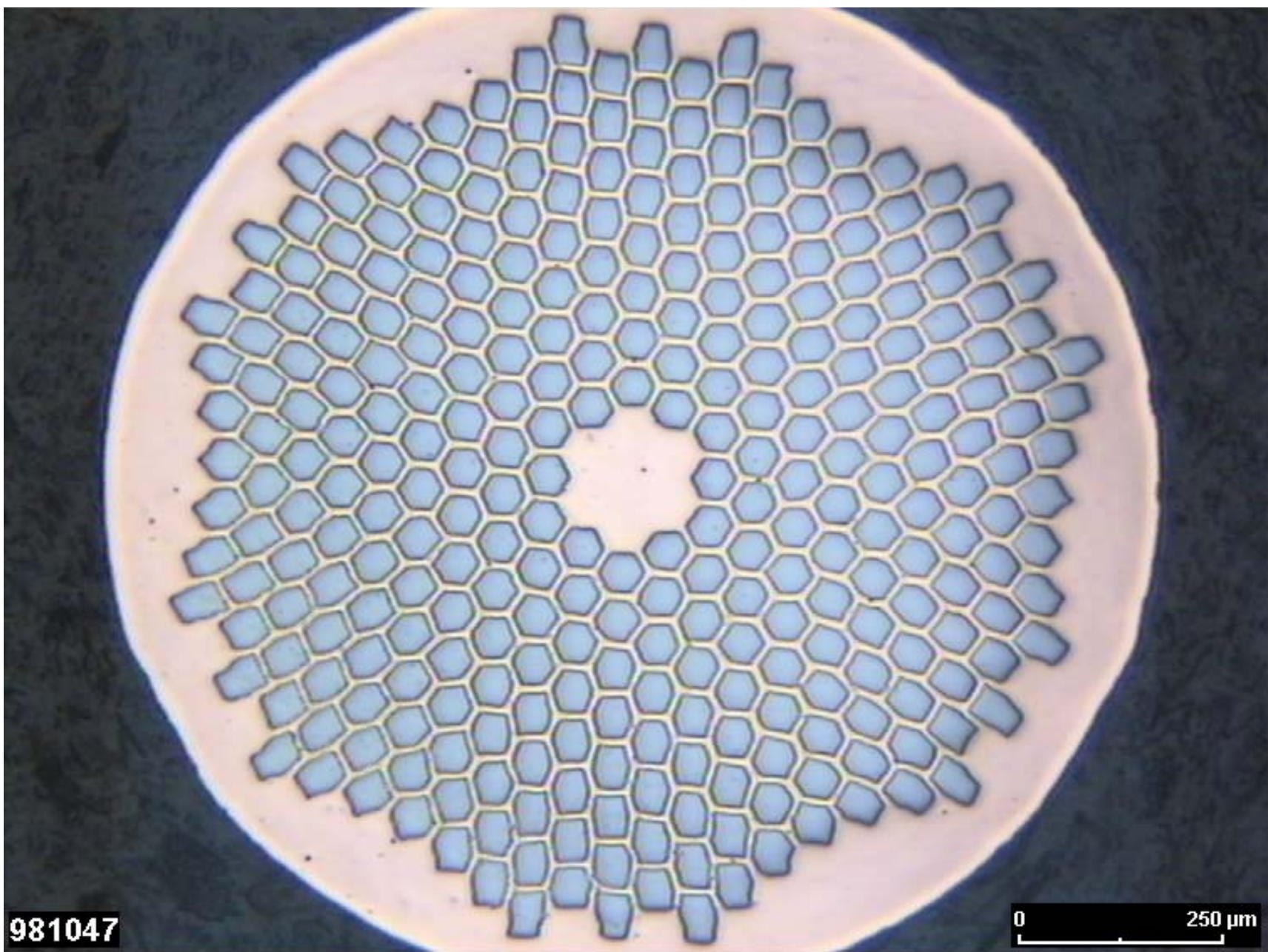

981047

0 250 μm

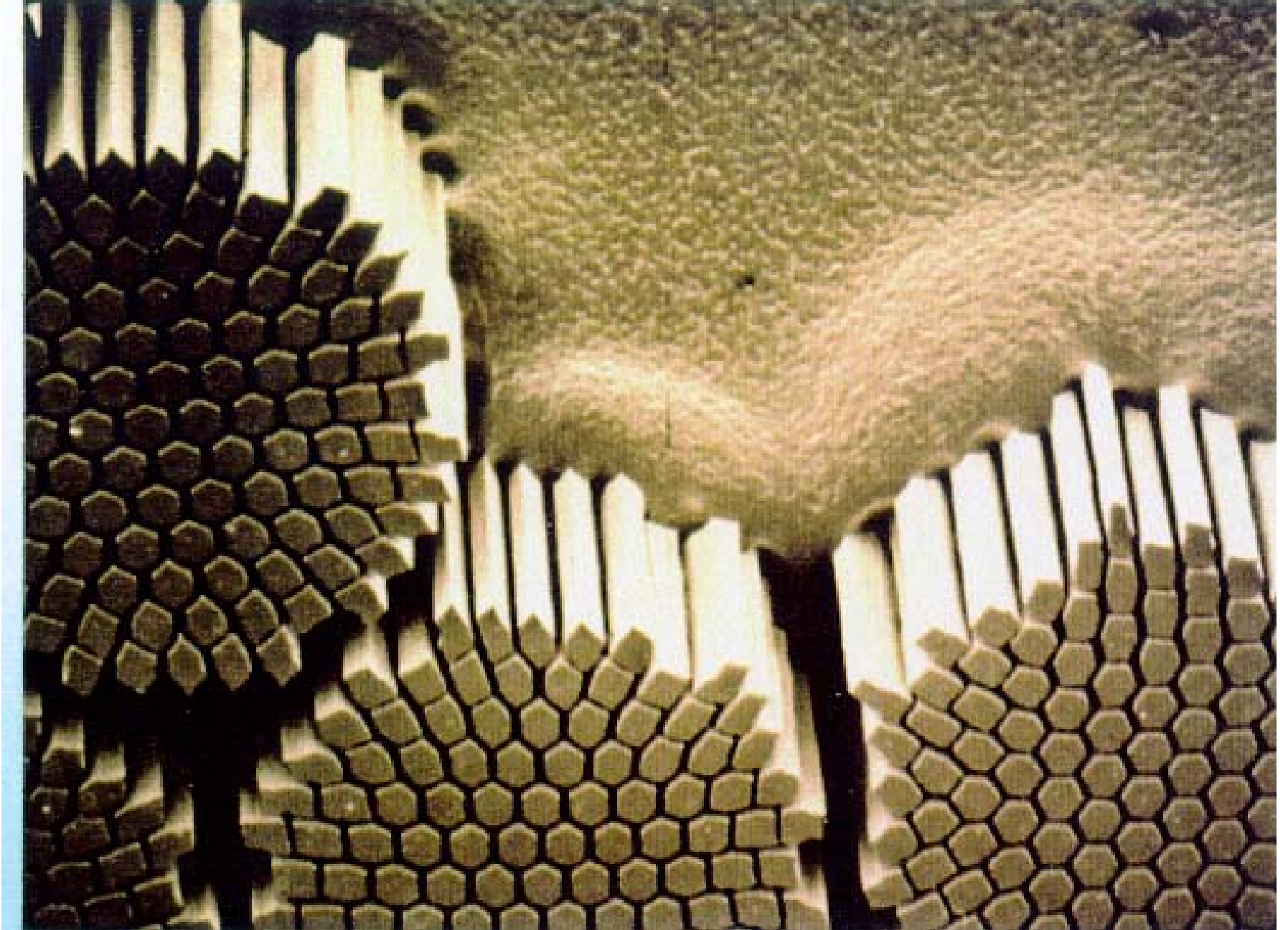

Superconducting Magnets
Summer 2006 Tom Taylor

The need for cables

- A single 5 μ m filament of NbTi in 6T carries 50mA
- A composite wire of fine filaments typically has 5,000 to 10,000 filaments, so it carries 250A to 500A
- For good tracking we connect synchrotron magnets in series
- For stored energy E , rise time t and operating current I , charging voltage V

$$E = \frac{1}{2} LI^2 \qquad V = \frac{LI}{t} = \frac{2E}{It}$$

for 5 to 10kA, we need 20 to 40 wires in parallel --- a cable

RHIC at BNL $E = 40\text{kJ/m}$, $t = 75\text{s}$, 30 strand cable
cable $I = 5\text{kA}$, charge voltage per km = **213V**
wire $I = 167\text{A}$, charge voltage per km = **6400V**

FAIR at GSI $E = 74\text{kJ/m}$, $t = 4\text{s}$, 30 strand cable
cable $I = 6.8\text{kA}$, charge voltage per km = **5.4kV**
wire $I = 227\text{A}$, charge voltage per km = **163kV**

Types of cable

- Cables carry a large current and this generates a **self field**
- Wires are twisted to avoid flux linkage between the filaments, for the same reasons we should avoid flux linkage between wires in a cable
- BUT twisting this cable doesn't help if the inner wires are always inside and the outer outside

- Wires must be fully **transposed**, i.e. every wire must change places with every other wire along the length of the cable so that, on the average, no flux is enclosed
- three types of fully transposed cable have been tried in accelerators
 - rope
 - braid
 - Rutherford

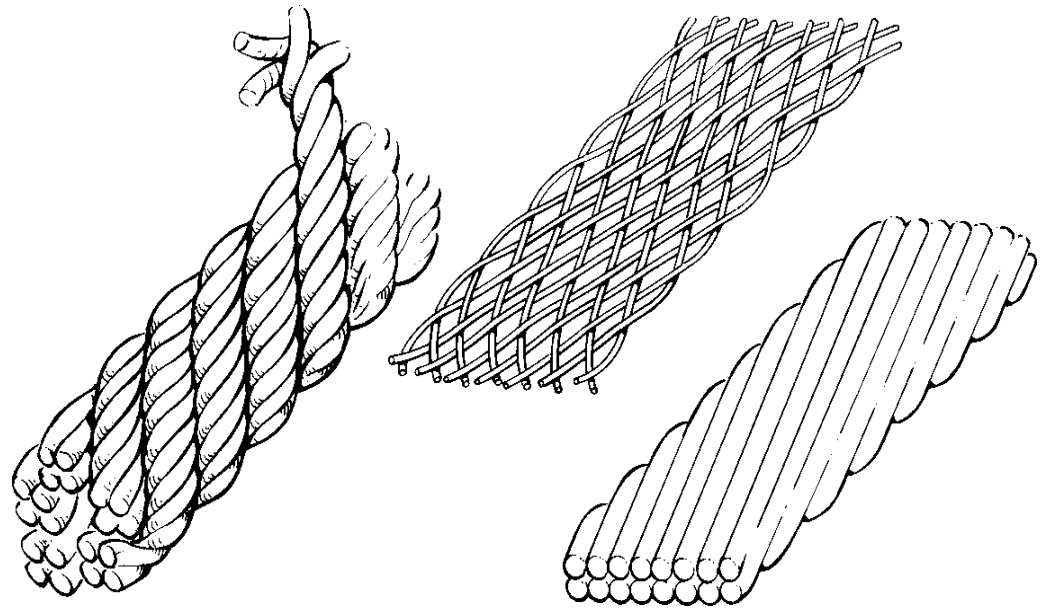
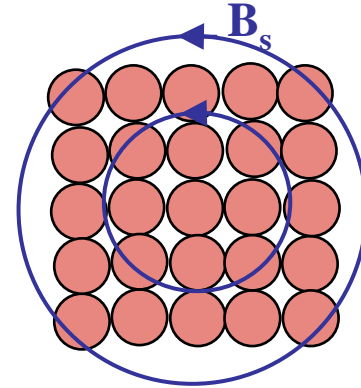

Rutherford cable

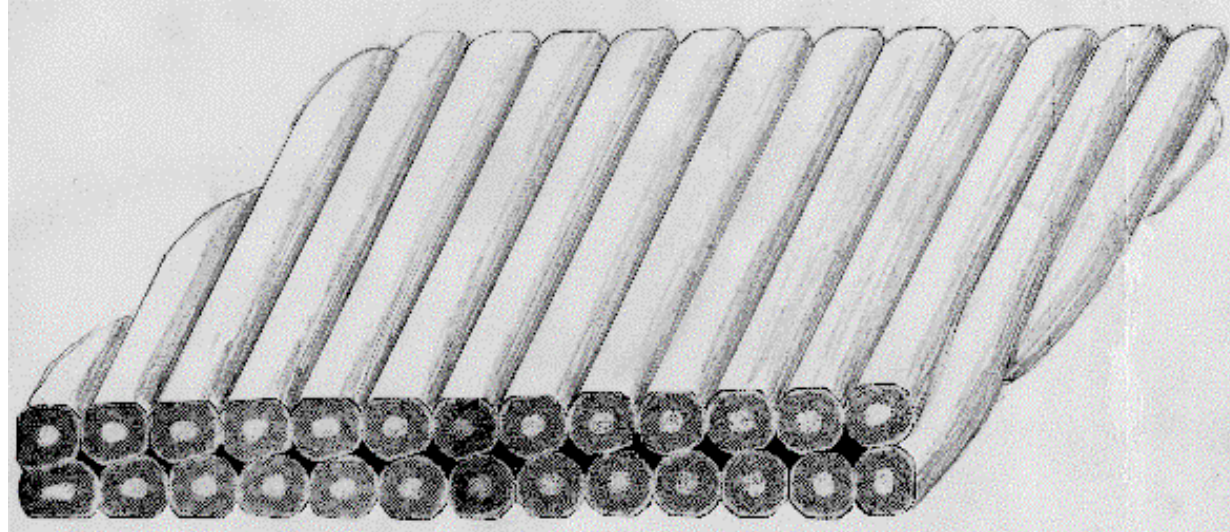

- So-called because it was first proposed by the team at the Rutherford Lab.
- The cable is usually insulated by wrapping 2 or 3 layers of Kapton, with gaps to allow penetration of liquid helium. The outer layer is adhesive layer for bonding adjacent turns.
- NB: the adhesive faces outwards, not bonding to the cable (to avoid energy release by bond failure, which could quench the magnet)

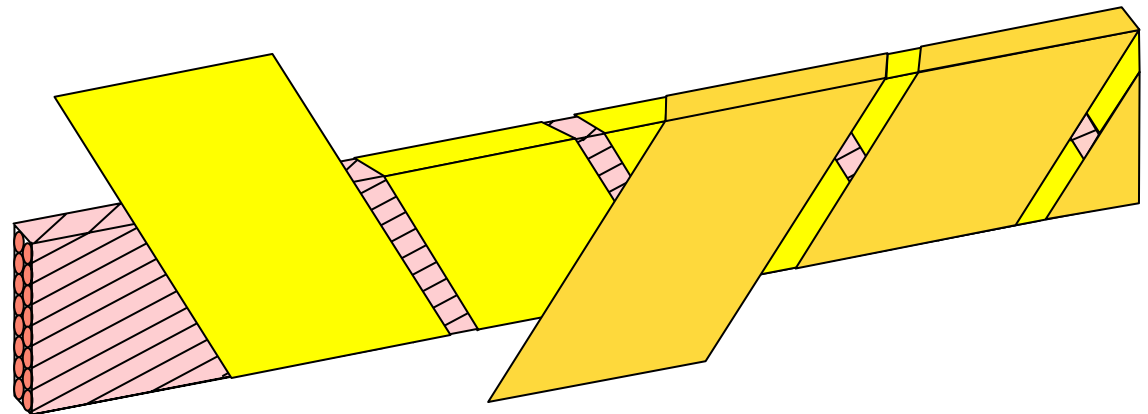

Rutherford cable

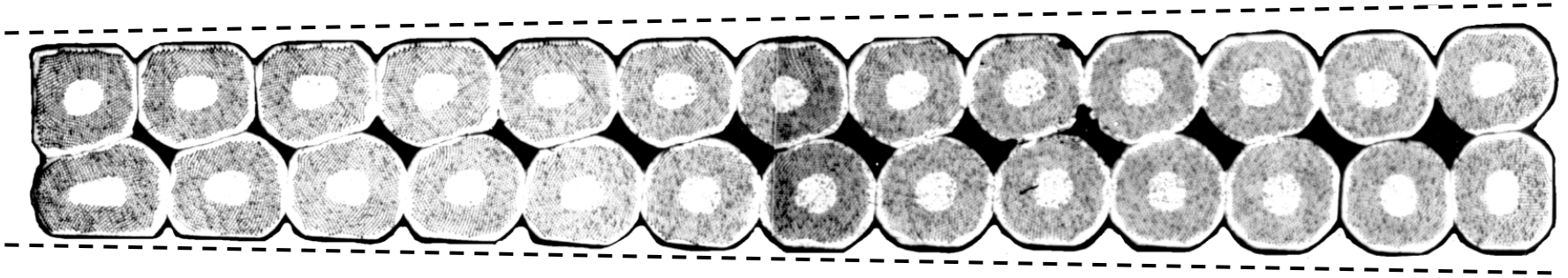

Reasons for success of Rutherford cable

- It **can be compacted to a high density** (88 - 94%) without damaging the wires;
- It can be **rolled accurately** ($\sim 10\mu\text{m}$);
- It can be given a **'keystone angle'**, improving stacking around a circular aperture.

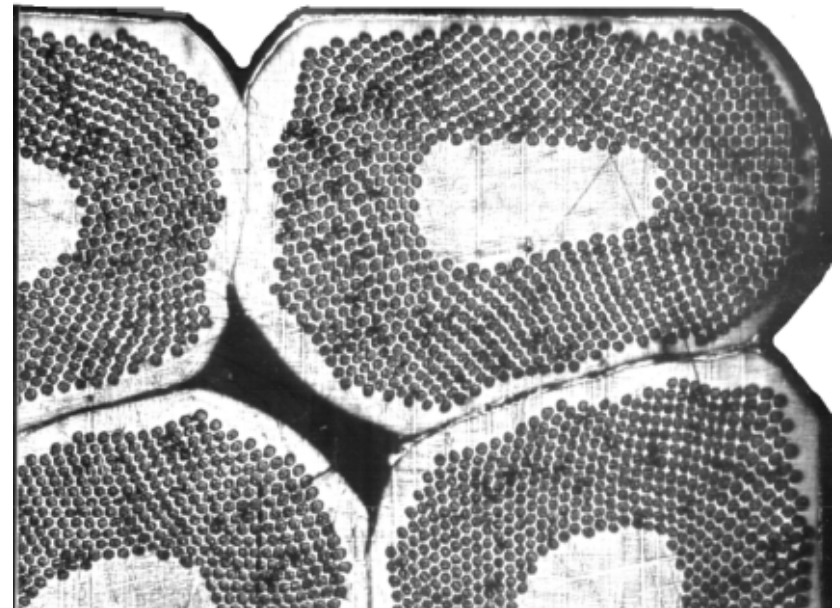

Cable manufacture

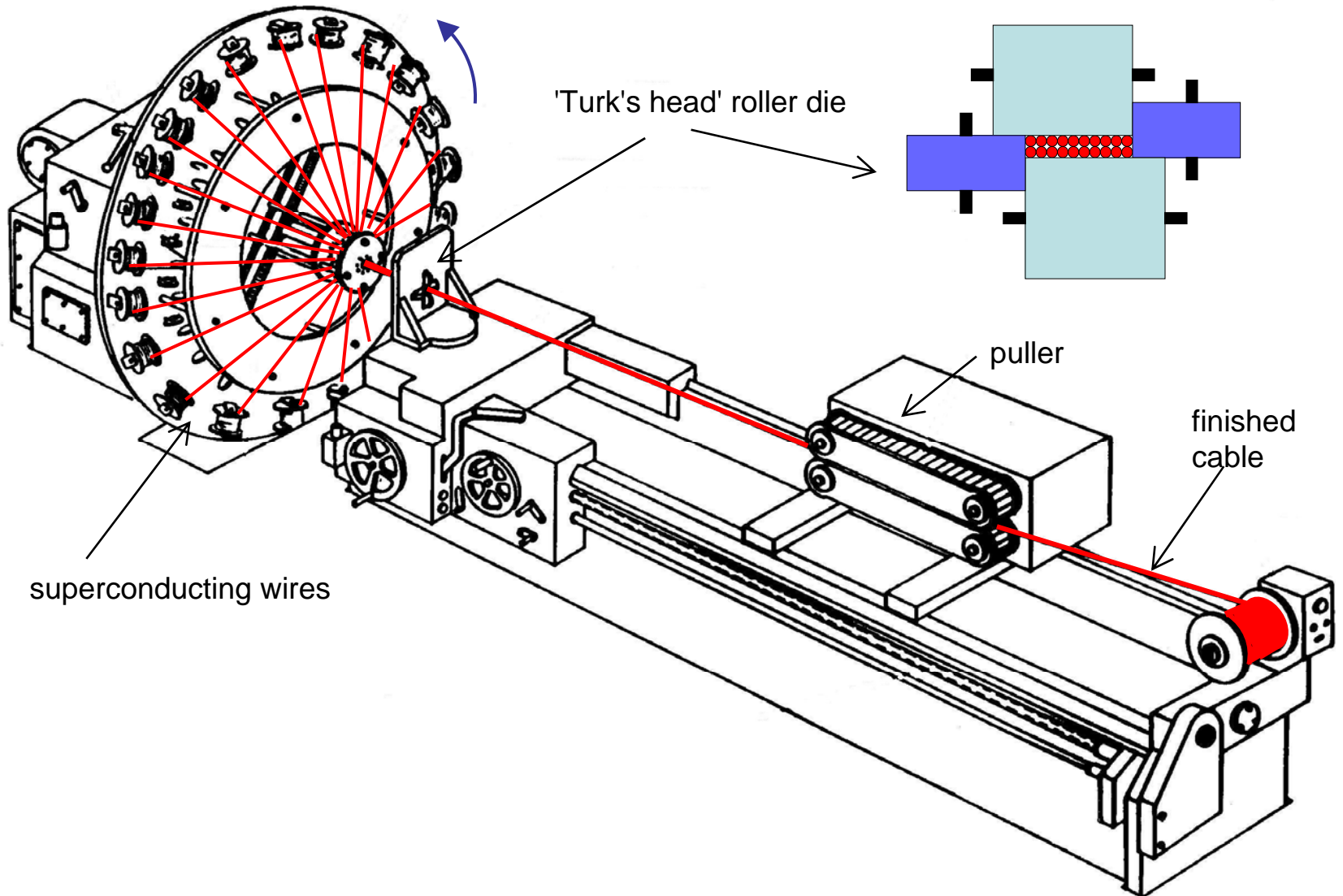

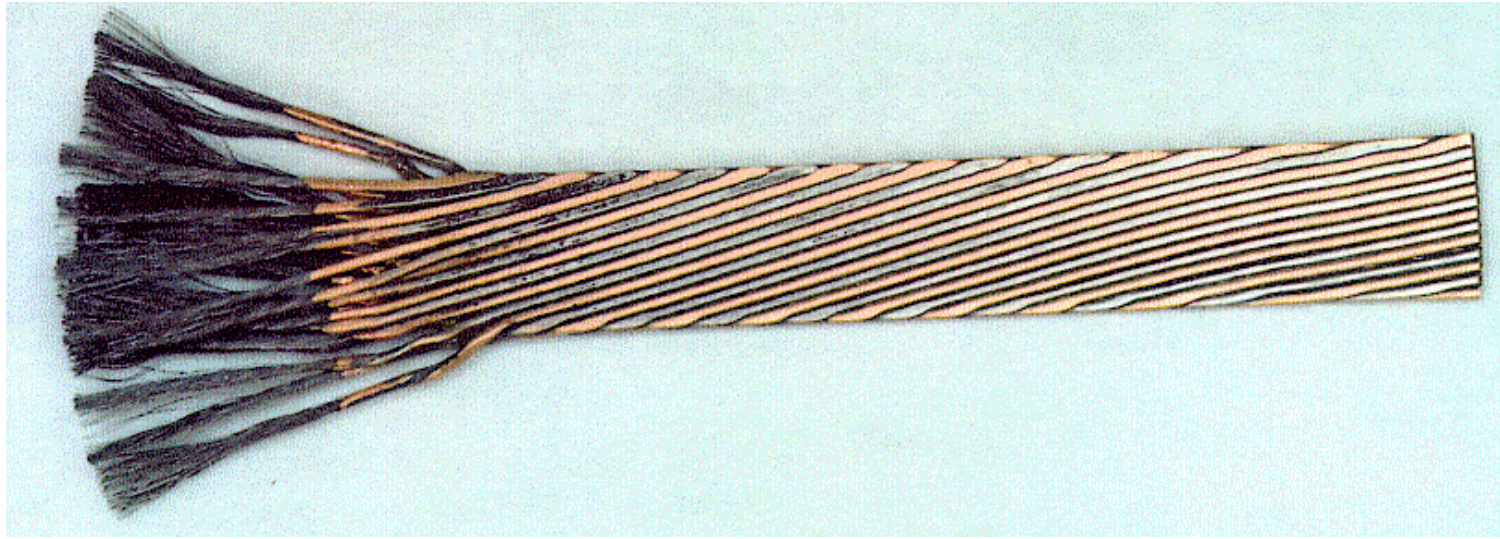

LHC dipole cable

**ATLAS conductor:
Rutherford cable
embedded in pure
aluminium stabilizer**

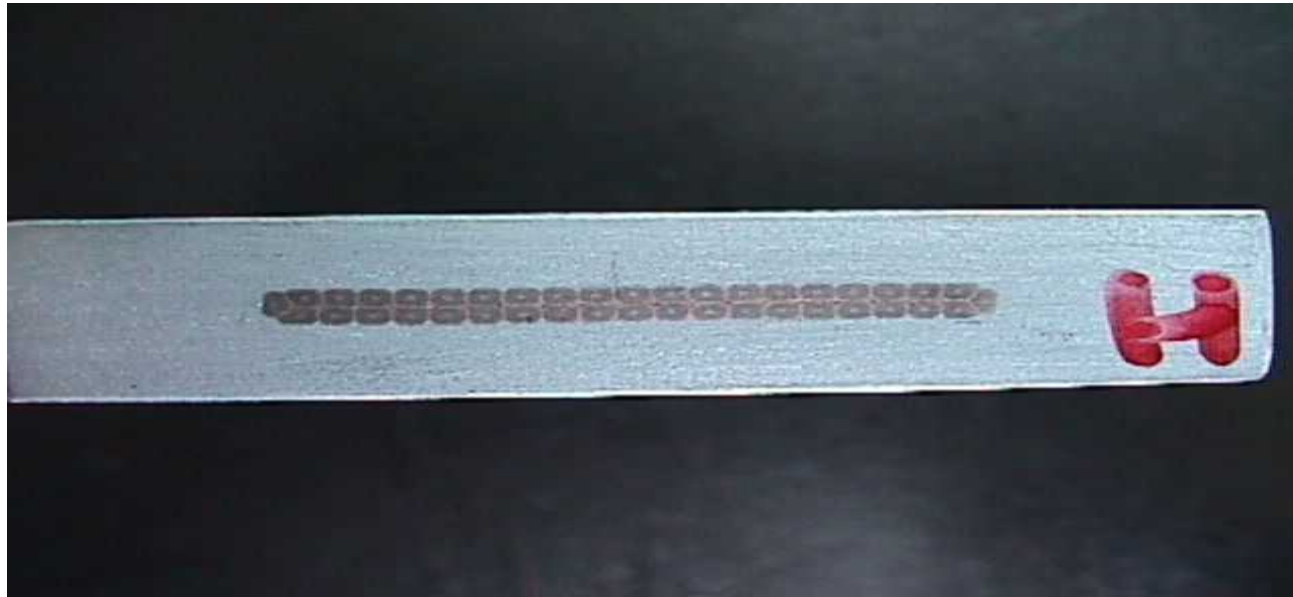

Superconducting magnet design (accelerators)

Intersecting ellipses
generate uniform field

Two intersecting ellipses,
rotated of 90° , generate a
perfect quadrupole field

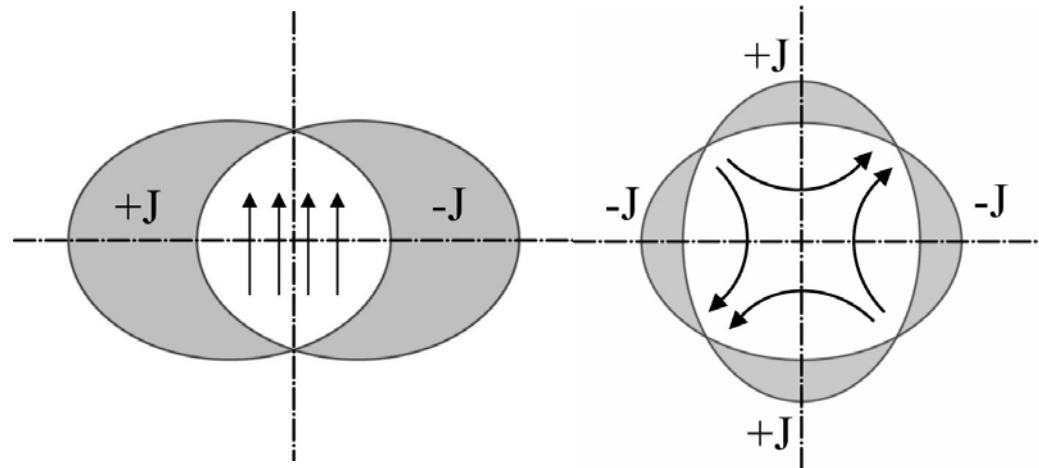

$$B_y = \frac{\mu_0 Jbd}{a + b}$$

$$B_x = \frac{\mu_0 J(a - b)}{a + b} y$$

$$B_y = \frac{\mu_0 J(a - b)}{a + b} x$$

Etc. for higher orders

$J_s = J \cdot \cos(\theta)$, $J_s = J \cdot d \cdot \cos(2\theta)$, ...

In practice the above current distributions are approximate, so the field contains also higher order harmonics. But if the $\cos(n\theta)$ is approximated by blocks, these can be optimized to minimize the offending harmonics.

Accelerator magnet design - II

Shell with uniform current density and cut to eliminate the first higher-order harmonic

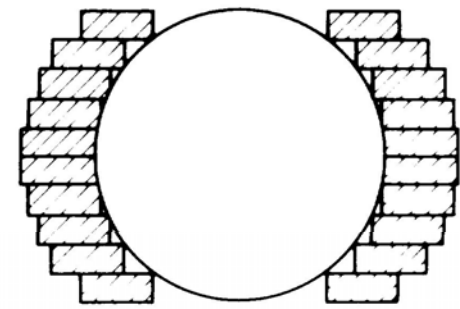
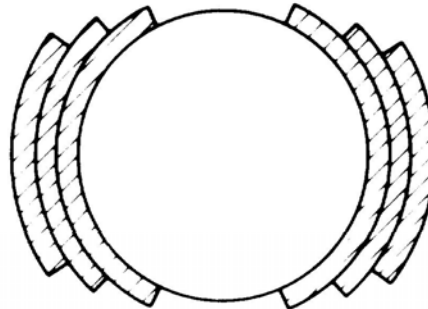
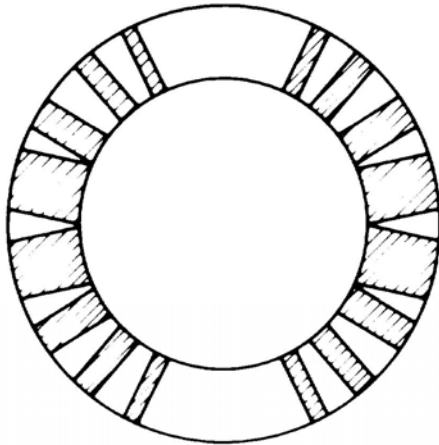
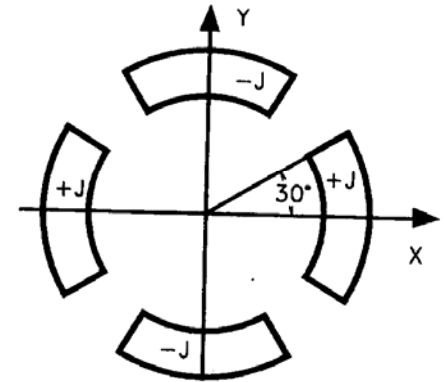
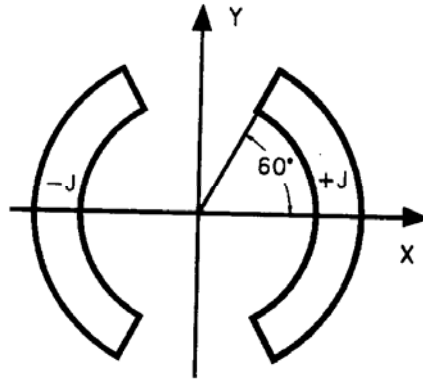

Better approximations of $\cos\theta$ with coil blocks (left) and multiple shells (centre), and of intersecting ellipses (from Wilson book)

Accelerator magnet design - III

$J_{\text{overall}} \approx 500 \text{ A/mm}^2$ e.m. forces are not held by conductors – they tend to tear apart the winding

Concept

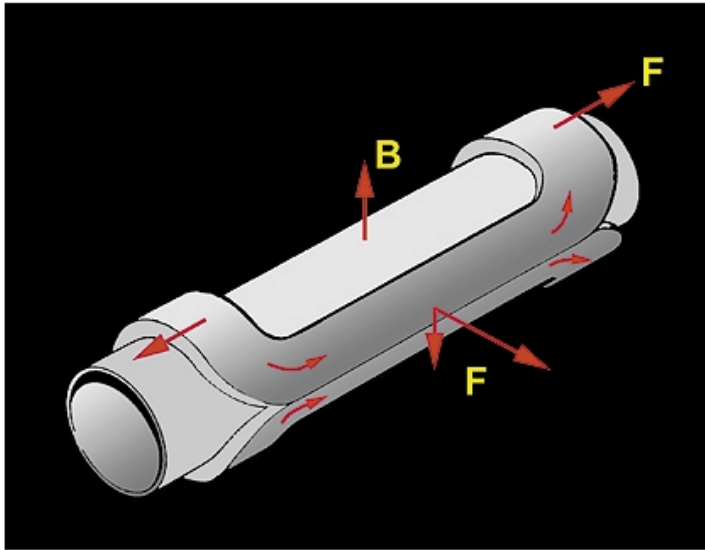

Reality

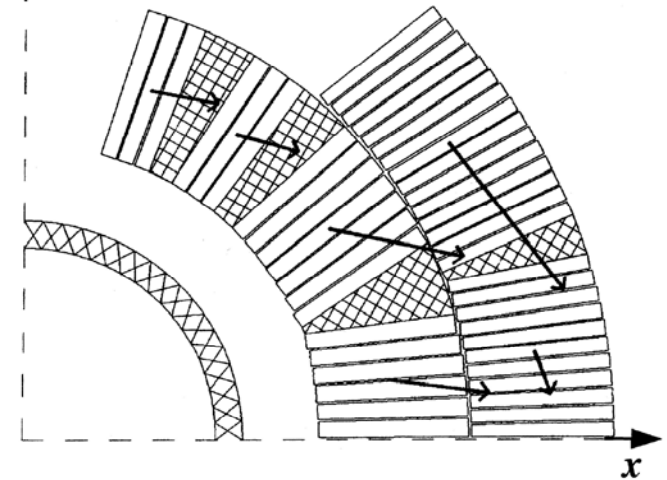
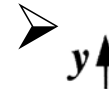

Electro-magnetic forces are
NOT SELF-SUPPORTING

Accelerator magnet design

So real magnets use blocks of conductors to approximate the ideal cosine theta distribution of current density.

There are sophisticated programs available to do this, e.g. ROXIE, Opera, etc.

ROXIE also generates the data for machining the end spacers

For calculating the effect of the forces ANSYS is used.

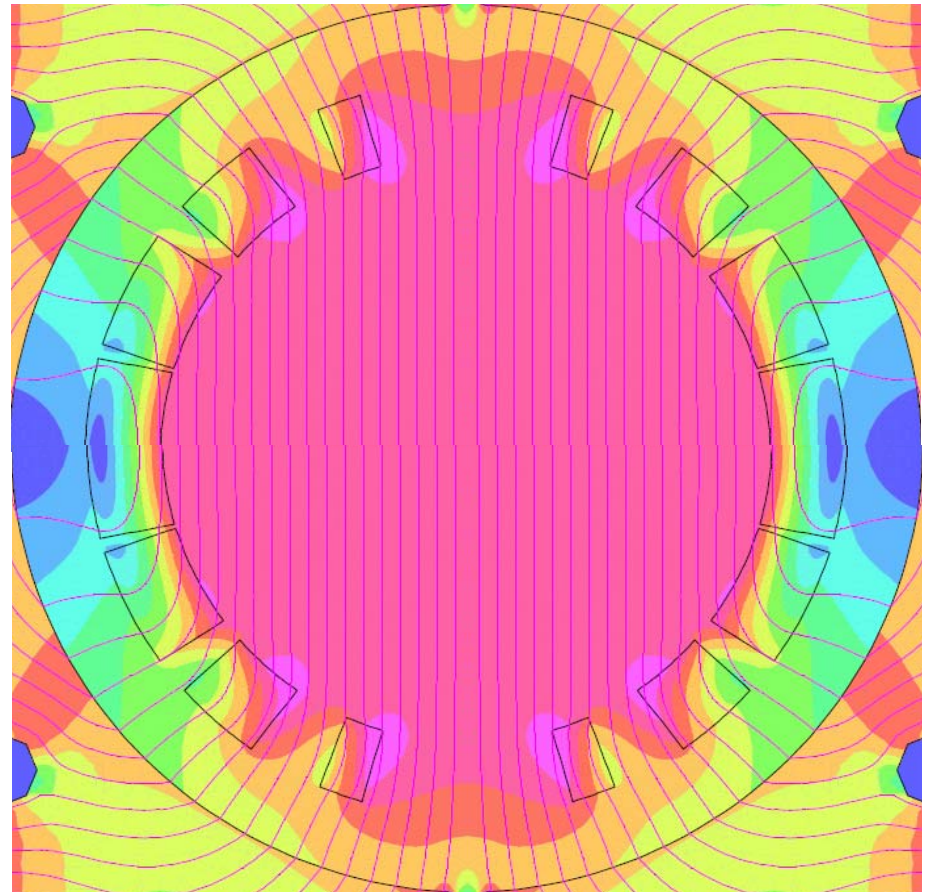

End winding and spacers

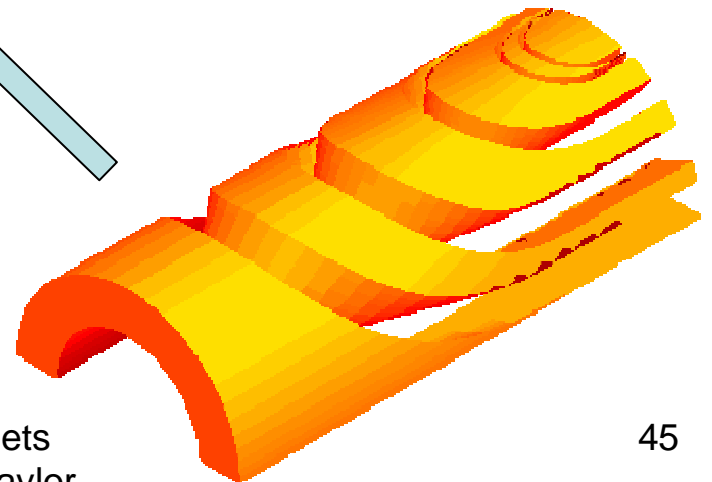
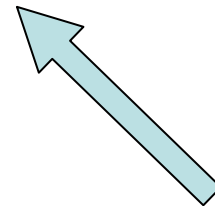
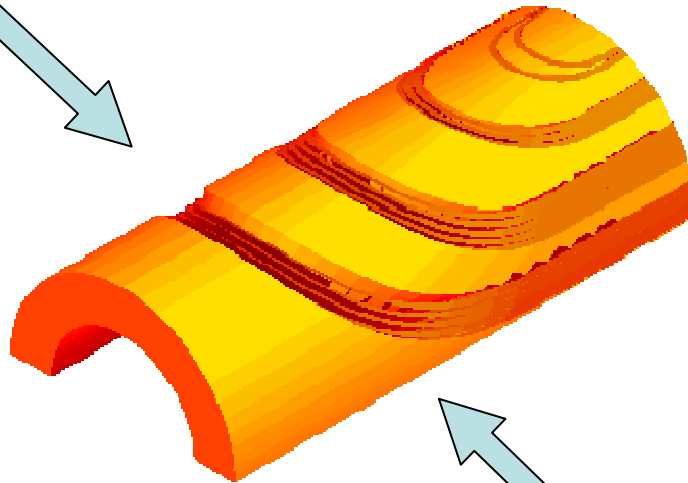
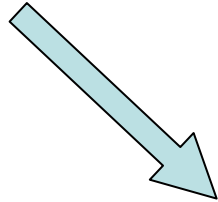
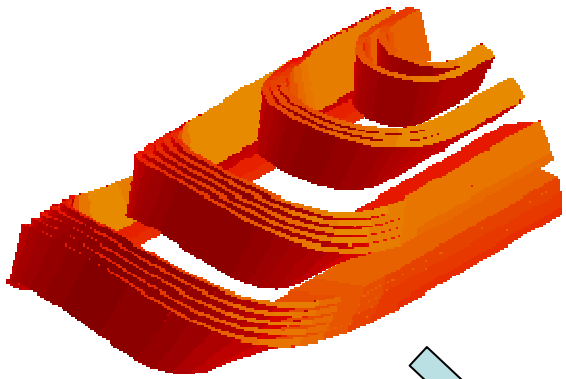

End Spacers have a complicated topology. Their optimization is critical for mechanical stability

Critical line and magnet load lines

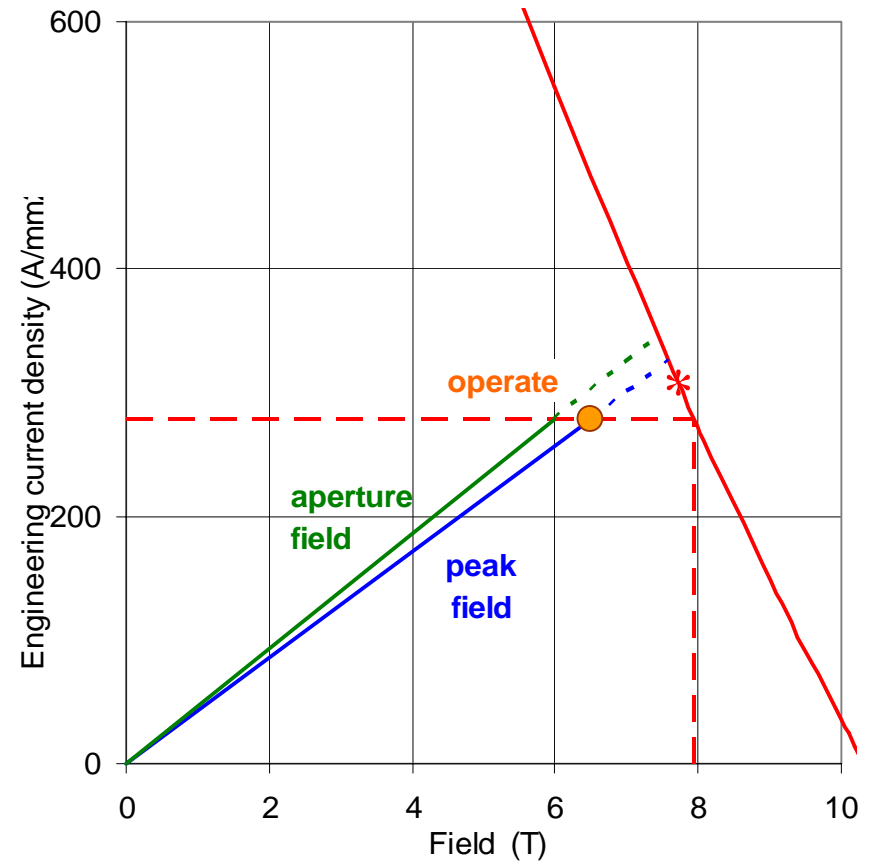
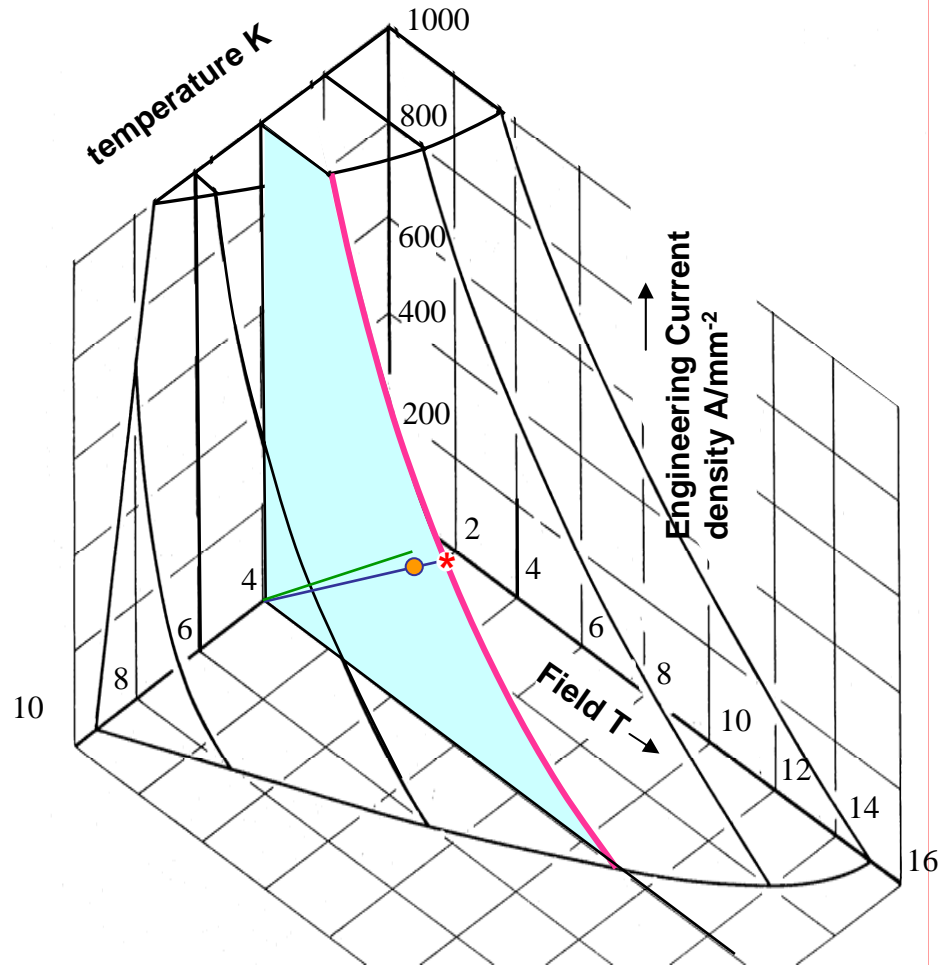

Expect the magnet to go resistive (i.e. **quench**) where the peak field load line crosses the critical current line *

Better to go back from this extreme point and operate at ●

Temperature margin

Reduce the operating current in terms of temperature

- For safe operation include a **temperature margin**

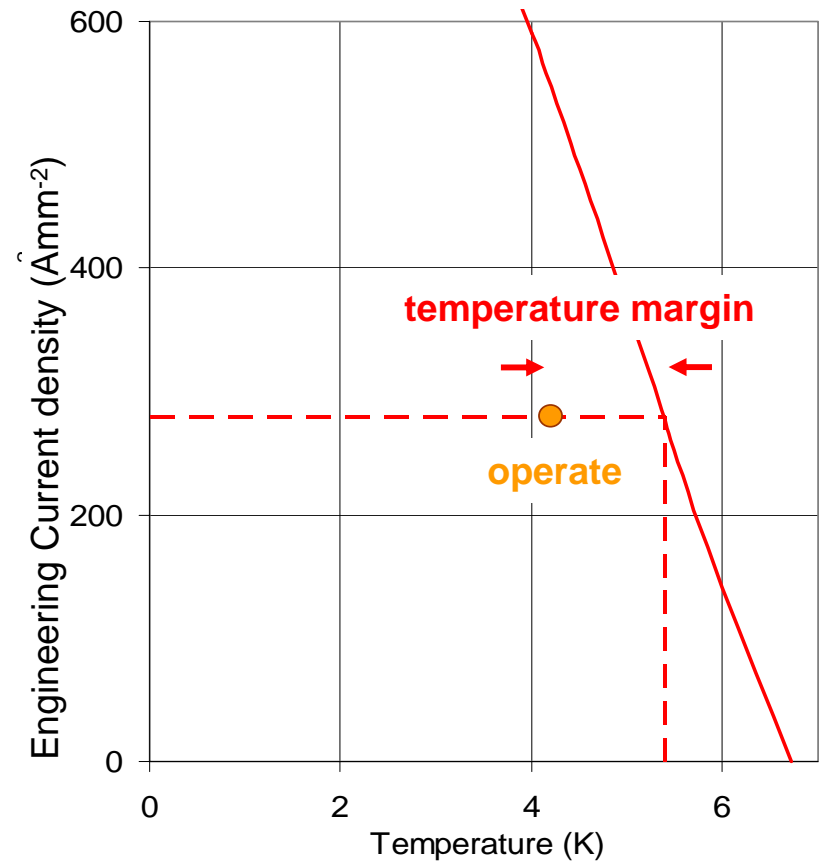
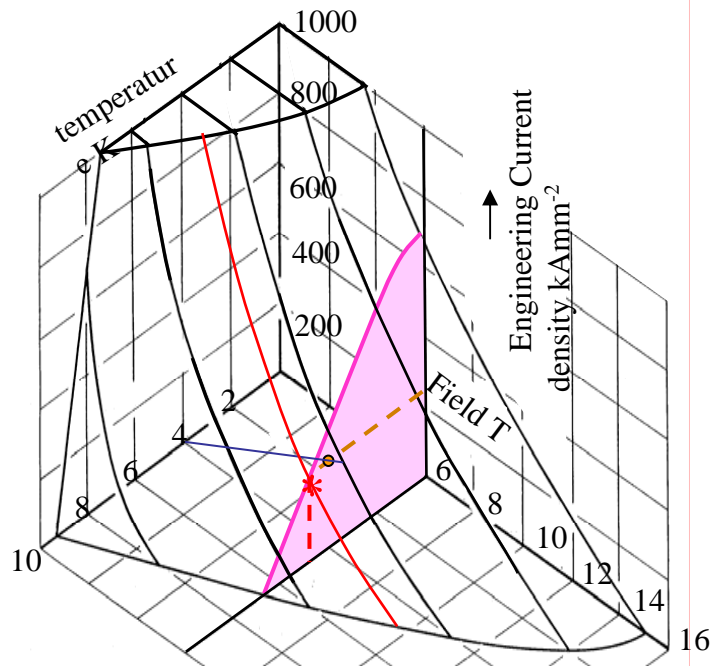

Temperature rise may be due to:

- Sudden internal energy release
- AC losses
- Poor joints
- Beam heating

Superconductors are not stable

Superconductors are NOT stable against perturbation.
 ΔE of μJ are enough to drive superconductor normal!

Heat capacity drops at low temperature ($T \ll T_{\text{Debye}}$):
 $C \propto T^3 \Rightarrow \Delta T = \Delta E / \gamma C$. So small ΔE generates big ΔT
 \Rightarrow operating point beyond critical surface \Rightarrow **QUENCH**

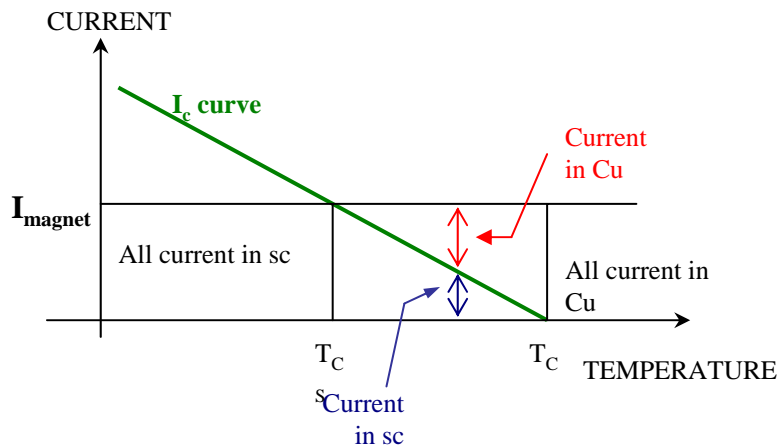
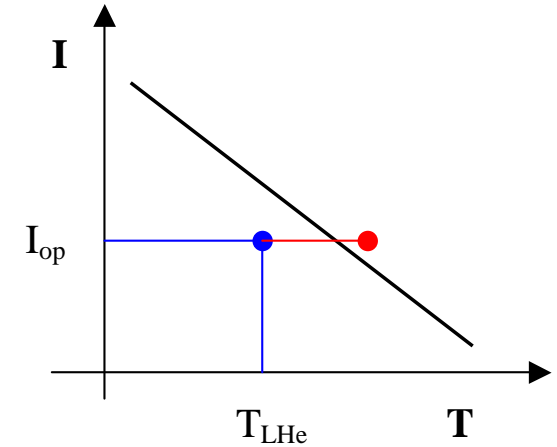

Electrodynamic stability: intimate contact between the superconductor and a highly conductive material.

Direct cooling: LHe, and more HELIUM, are good coolants, capable of removing heat in milliseconds! Latent heat 10-1000 times that of the specific heat of metals.

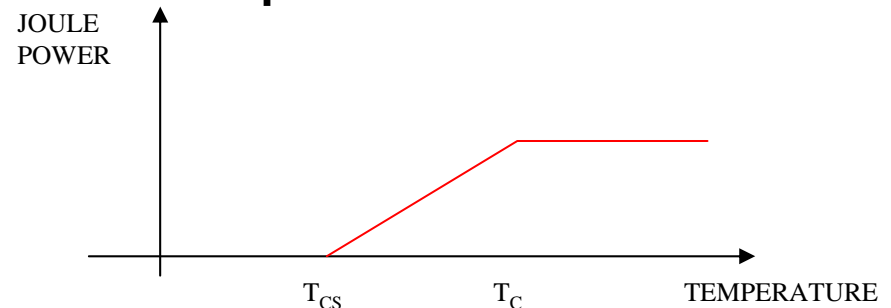

Magnet protection

Superconducting magnets, whatever the stability margin, **can quench**.

The magnet must be designed to survive!

For the LHC dipoles, **dissipation per unit volume following a quench is:**

$$\rho J_{Cu}^2 \cong 6 \cdot 10^{-10} \Omega m \cdot 10^{18} A/m^2 = 600 MW/m^3$$

Excessive voltage rise \Rightarrow insulation breakdown.

Excessive temperature \Rightarrow melting or damage to insulators / conductor.

Temperature gradients \Rightarrow excessive stress with subsequent de-training.

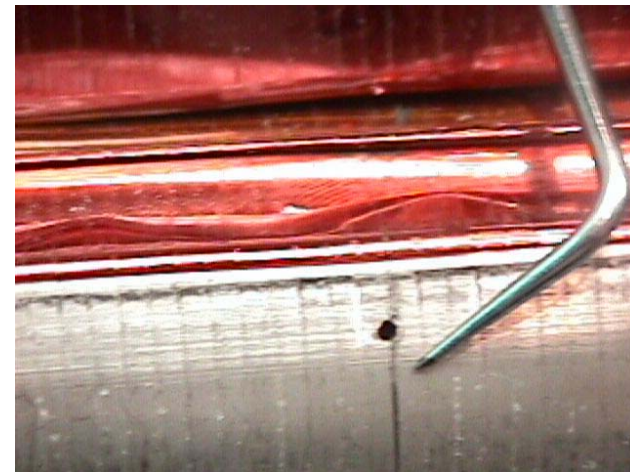

Damage caused by a short circuit developed during a quench in a LHC dipole prototype

Hot Spot Temperature can be calculated

We suppose that heat is by Joule effect only and conduction is not significant

$$J^2(t) \rho(T) dt = \gamma C(T) dT \quad \int_0^{\infty} J^2(t) dt = \int_{T_{op}}^{T_m} \frac{\gamma C(T)}{\rho(T)} dT \quad J_0^2 T_d = U(T_m)$$

MIITs

The function $U(T)$ can be computed, based only on material properties. If the magnet is discharged in a dump resistor, R_D , and $T_d = 0.5 \cdot L_{mag} / R_D$.

The goal is to speed up the quench propagation by any means, to avoid too high hot spots:

1) **Heater : activated in 20 ms !!**

2) **Benefit of quench-back**

This goes against having LHe inside the coils (i.e. is against stability)!

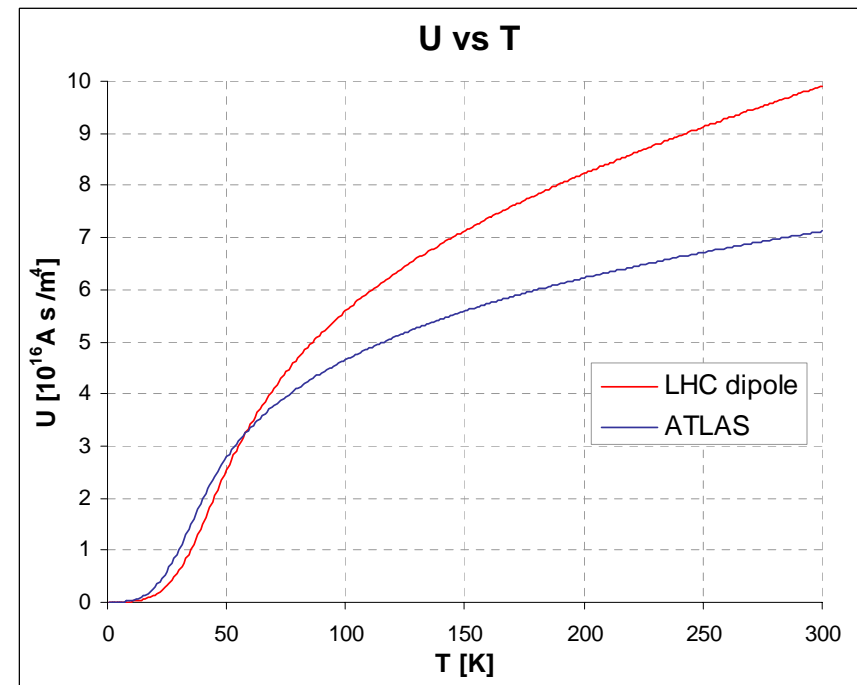

Training *Example of an early LHC dipole magnet*

MBSMS3.V1 and MBSMS3.V4
Training Curve @ 1.8K (including "de-training" test)

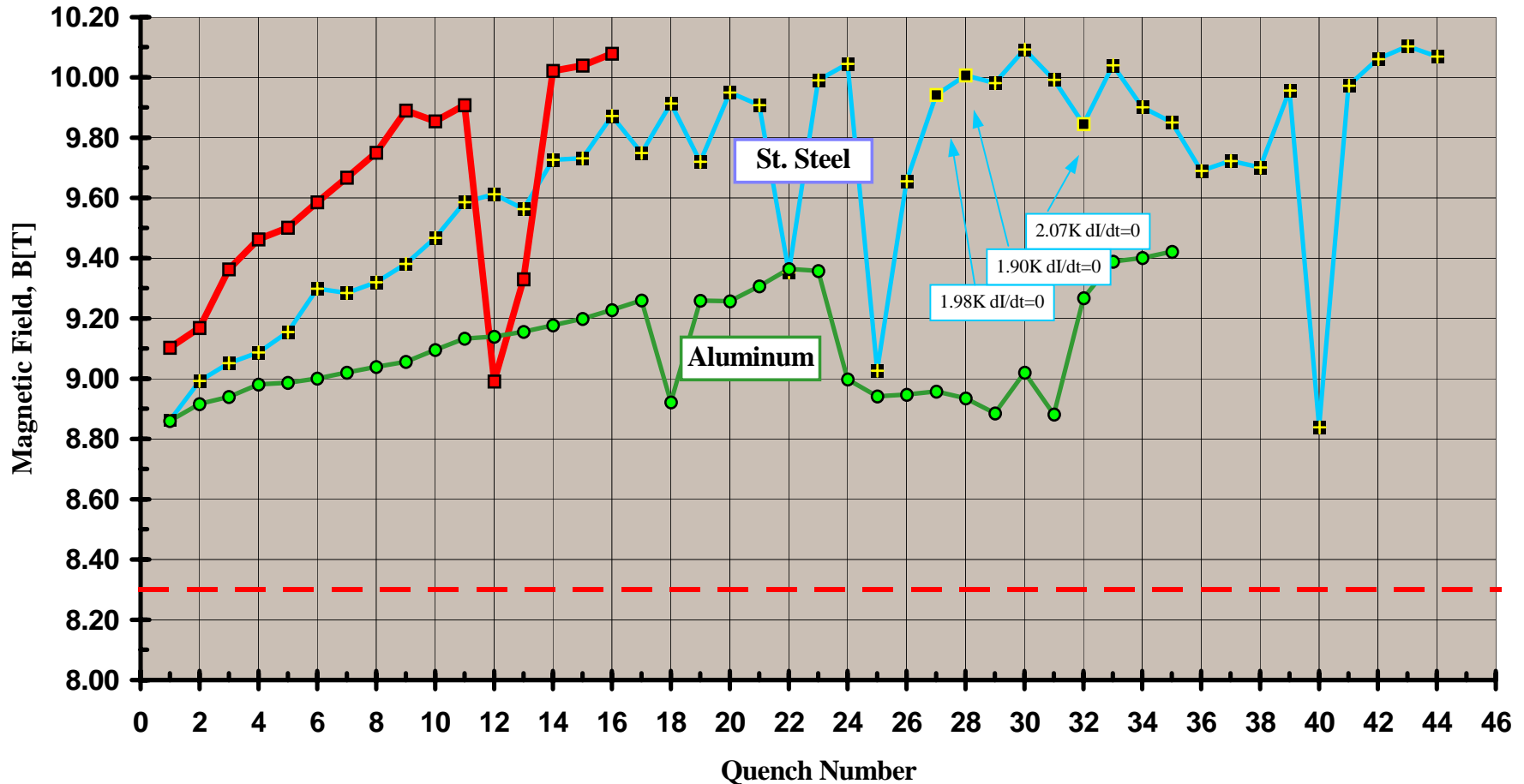

■ MBSMS3.V4_Run1 ■ MBSMS3.V4_Run2 ● MBSMS3.V1 - - B_{nom} = 8.3 T

Causes of training

1. Low specific heat

- The specific heat of everything reduces with temperature
- at 4.2K, it is ~2,000 times less than at room temp.
- a given release of energy in the winding produces a temperature rise 2,000 times greater than at RT
- Small energy release can be catastrophic !

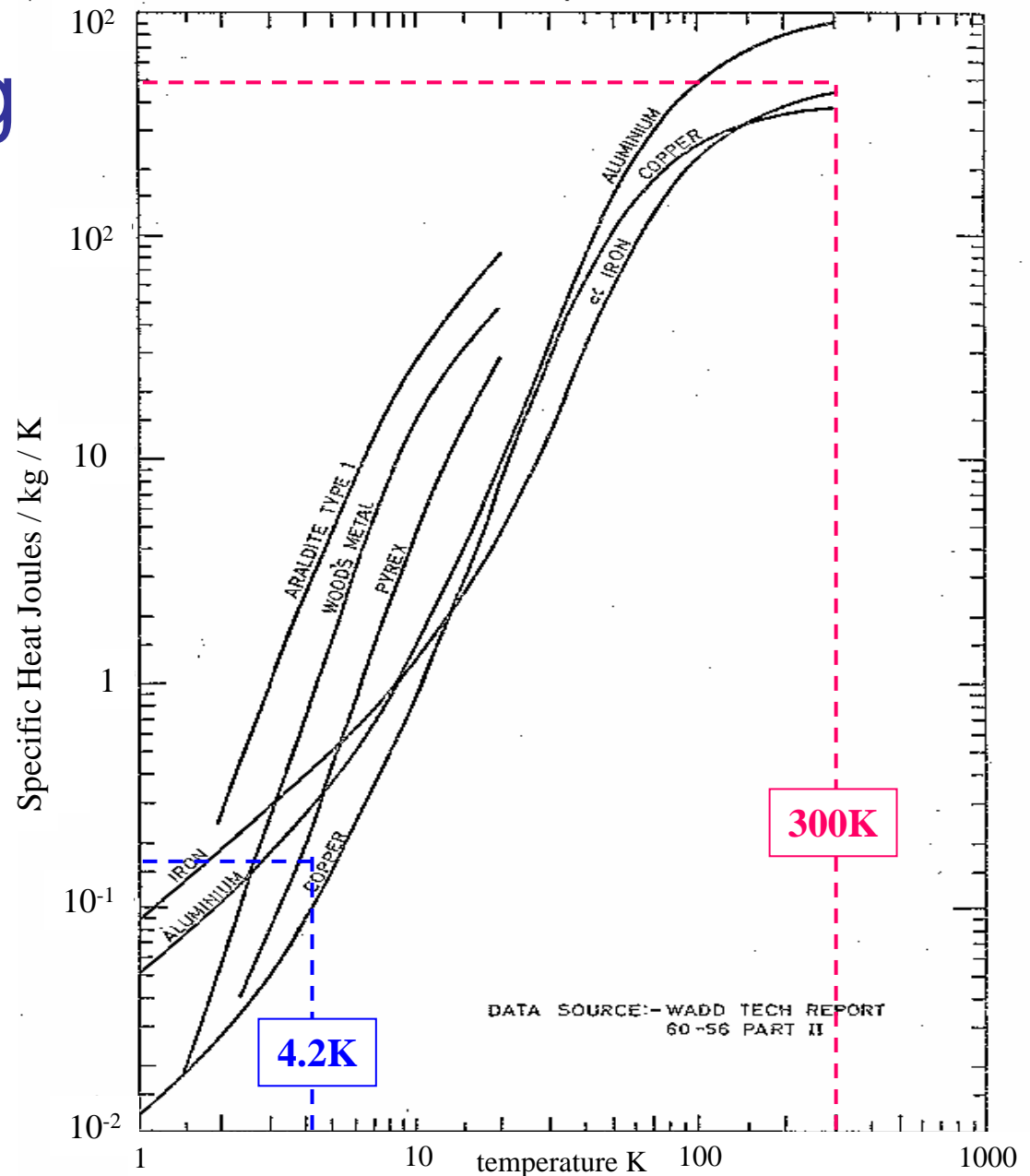

Causes of training:

2. High forces

Conductors are subjected electromagnetic forces. Sudden movement occur.

A large fraction of the work done is released as frictional heating.

- A small energy release can be catastrophic !
- This really needs

VERY careful engineering !

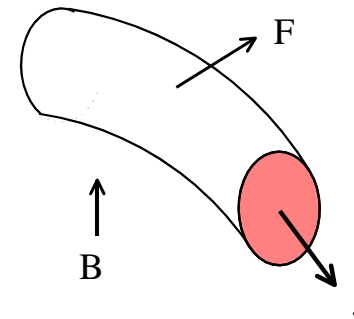

Work done per unit length of conductor if it is pushed distance dz

$$W = F \cdot dz = B \cdot I \cdot dz$$

Frictional heating per unit volume

$$Q = B \cdot J \cdot dz$$

typical numbers for Nb-Ti:

$$B = 5\text{T} \quad J_{eng} = 5 \times 10^8 \text{ A}\cdot\text{m}^{-2}$$

so if $d = 10 \mu\text{m}$

$$\text{then } Q = 2.5 \times 10^4 \text{ J}\cdot\text{m}^{-3}$$

Starting from 4.2K

$$\theta_{final} = 7.5\text{K}$$

WOW!!!

Causes of training:

3. Differential thermal contraction

To stop wire movement impregnate the winding with epoxy resin. But resin contracts much more than the metal, so it goes into tension. And almost all organic materials become brittle at low temperature.

brittleness + tension \Rightarrow
cracking \Rightarrow *energy release*

- This also needs

VERY careful engineering !

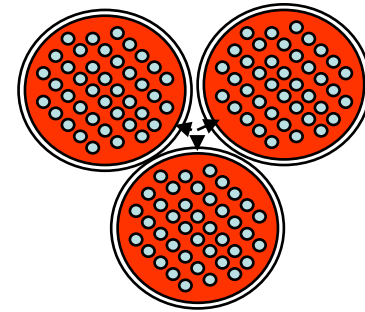

To calculate the strain energy induced in resin by differential thermal contraction
With

s = tensile stress, Y = Young's modulus
 e = differential strain, n = Poisson's ratio

$$\text{triaxial strain } Q_3 = \frac{3\sigma^2(1-2\nu)}{2Y} = \frac{3Y\varepsilon^2}{2(1-2\nu)}$$

Typically:

$$e = (11.5 - 3) \times 10^{-3}, Y = 7 \times 10^9 \text{Pa}, n = 1/3$$

$$\text{Giving } Q_3 = 2.3 \times 10^6 \text{ J.m}^{-3} \text{ and } \theta_{\text{final}} = 28\text{K}$$

A large fraction of this stored energy can be released as heat during a crack

How to reduce training?

1. Reduce the disturbances occurring in the magnet winding

- make the winding fit exactly to reduce movement of conductors with field
- pre-compress the winding to reduce movement under field forces
- if using resin, minimize the volume and choose a crack resistant type
- match thermal contractions - fill epoxy with mineral or glass fibre
- most accelerator magnets are insulated using a Kapton film with a very thin adhesive coating

2. Make the conductor able to withstand disturbances without quenching

- increase the temperature margin
 - operate at lower current
 - higher critical temperature - HTS?
- increase the cooling
- increase the specific heat

Concept of

Minimum Quench Energy MQE

= energy input at a point which is just enough to trigger a quench

Minimum propagating zone MPZ

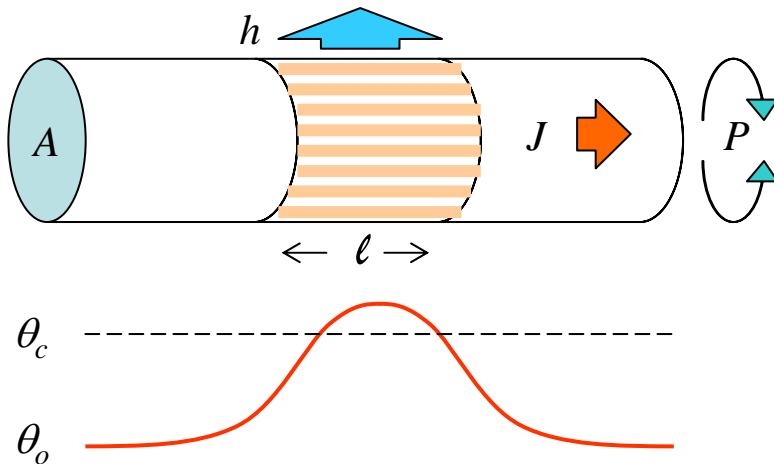

- If heat is conducted out of the resistive zone faster than it is generated, the zone will shrink – if not, it will grow.
- Consider a conductor where a short section has been heated, so that it is resistive; the boundary between the two conditions is called the minimum propagating zone

MPZ

- Make MPZ large for better stability

The balance point is found by equating heat generated to heat removed

The energy to produce MPZ is called the Minimum Quench Energy **MQE**

Wires, cables and stabilized conductors

Recap. – superconductors are multifilamentary wires, where hundreds or thousands of fine filaments are embedded in a stabilising matrix. The wire is strongly twisted (5-50 mm pitch length) for stability.

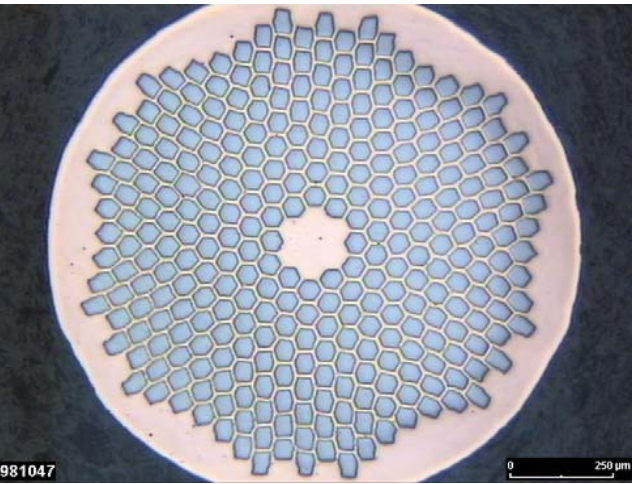

← Atlas Cu/NbTi wire

AMS-02 Cu/NbTi/Al →

Rutherford cable for
↓ LHC dipole

Atlas conductor
(Rutherford cable
coextruded with pure Al) ↓

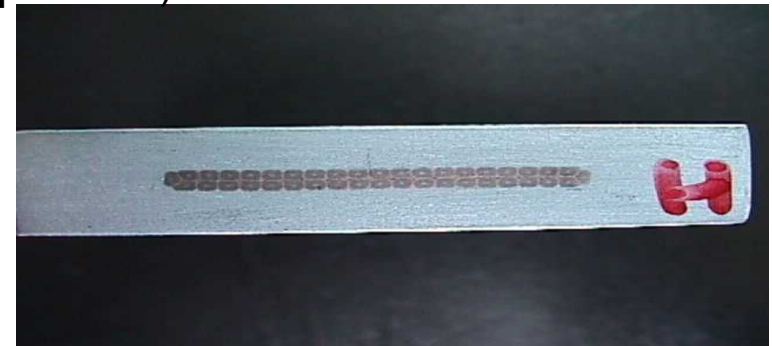
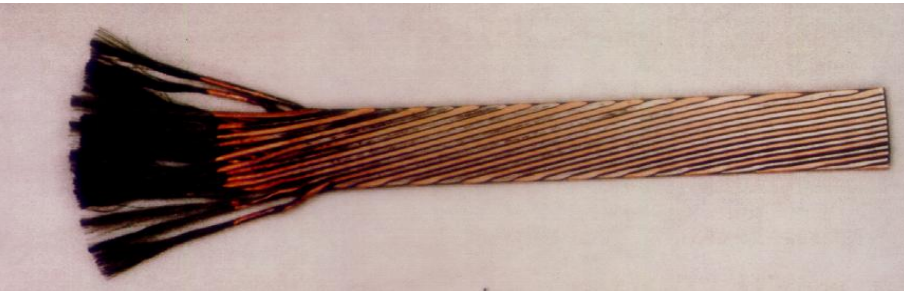
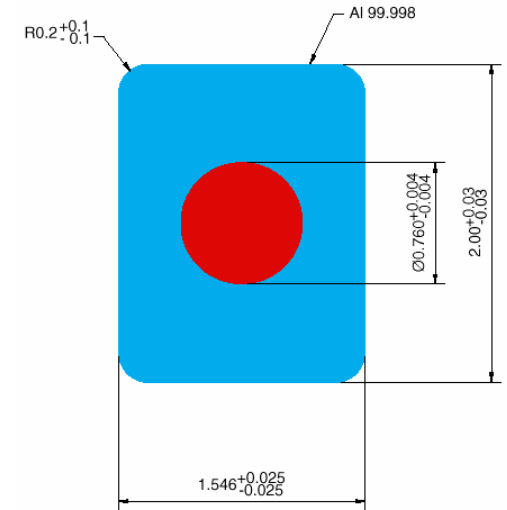

LHC DIPOLE

CROSS SECTION

Twin Concept:
MB Main Bend
(Dipole)

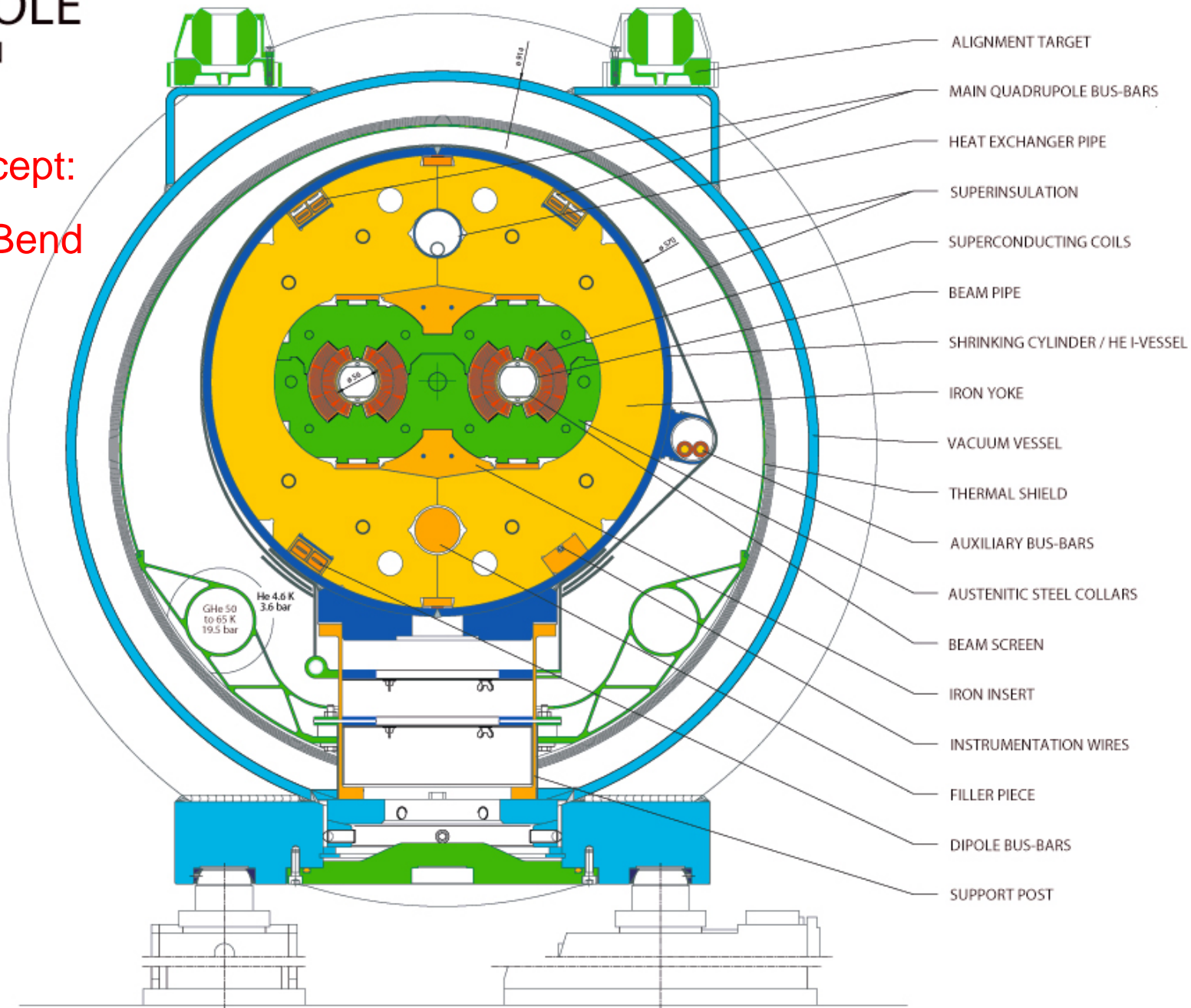

Niobium-Titanium in superfluid He

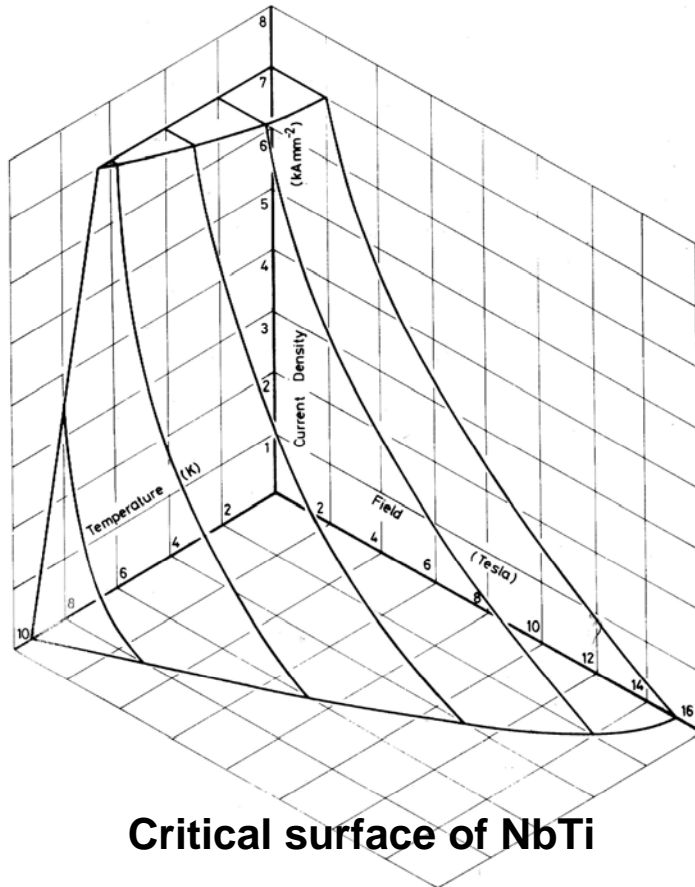

Critical surface of NbTi
(from Wilson textbook)

Critical current density vs field measured on NbTi multiflamentary wire at 4.22 and 2.17 K

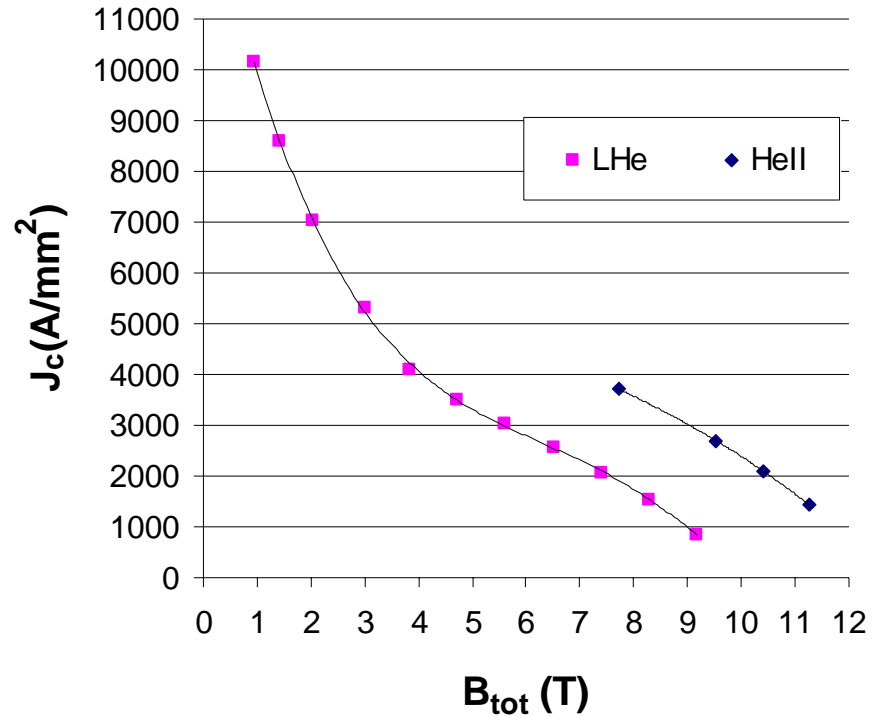

➡ **Shift of ~ 3T**

Optimization of magnet cross-section:

1) Conductor (Rutherford cable)

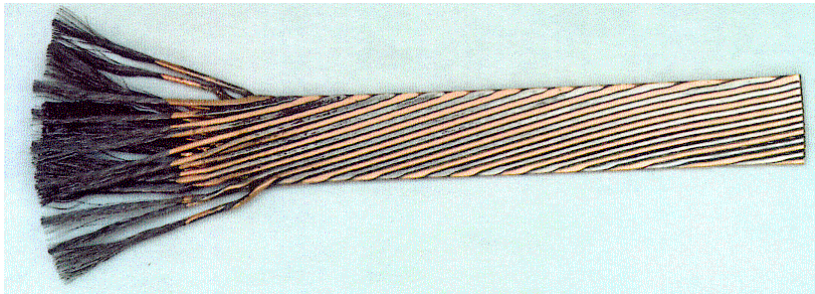
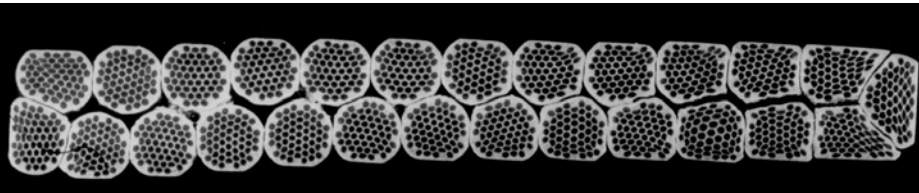

Conductor size control:

Needs to be very accurate to avoid error build-up

Conductor position optimization:

Control of harmonics

Balance of margin among blocks

Stable against inevitable errors

Minimum shear among conductors

Optimization of magnet cross-section:

2) Inter-block wedges

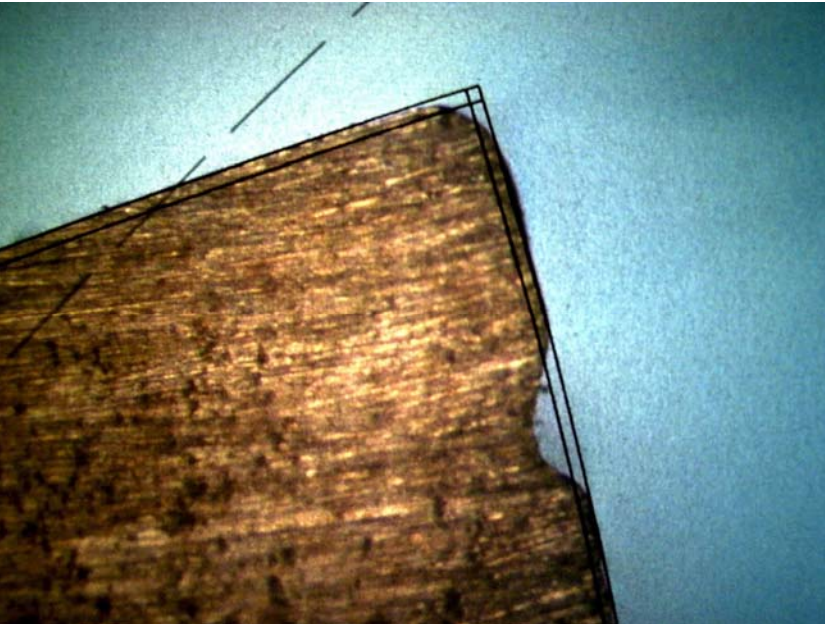

Precise to $\pm 20 \mu\text{m}$

Used to steer production towards correct Field Quality

For the LHC dipole they were adjusted slightly during production.

(~35 units have old X-section)

Optimization of magnet cross-section:

3) Insulation and inter-layer

Rutherford Cable Insulation

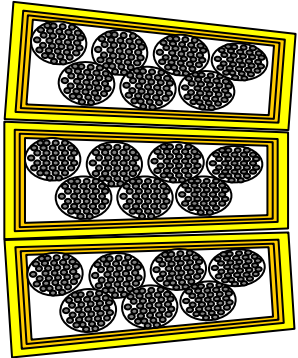

-2 layers of Apical
200 AV insulation
-1 layer Pixeo to glue
cables together at
185°C (-0,+5 critical)



Inter-layer “fishbone”

To allow
HEII to flow

Polyimide insulation

(Kapton or Apical)

Around cable and around coils

Important elements are
dimensions, $\pm 3\%$ of thickness,
and creep (Apical creeps less
than kapton)

Ground isolation

Four layers
125 μm polyimide

Critical Process: winding & curing the coil

- Coils are cured under press and measured all along 15 m
- Shims are introduced at the collaring stage
- Shims influence prestress, coil movements (quench) and magnetic field - at the μm level

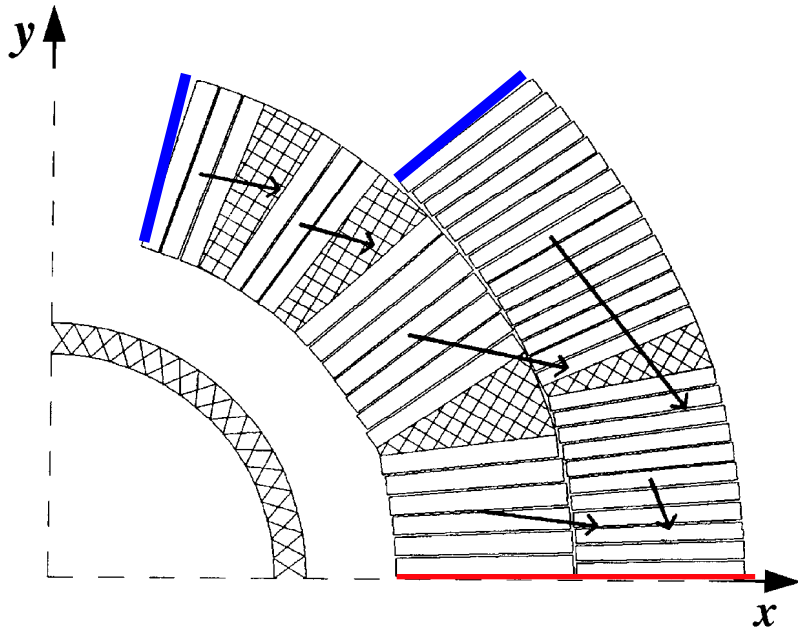

**Note the complexity of the coils
at the lead end**

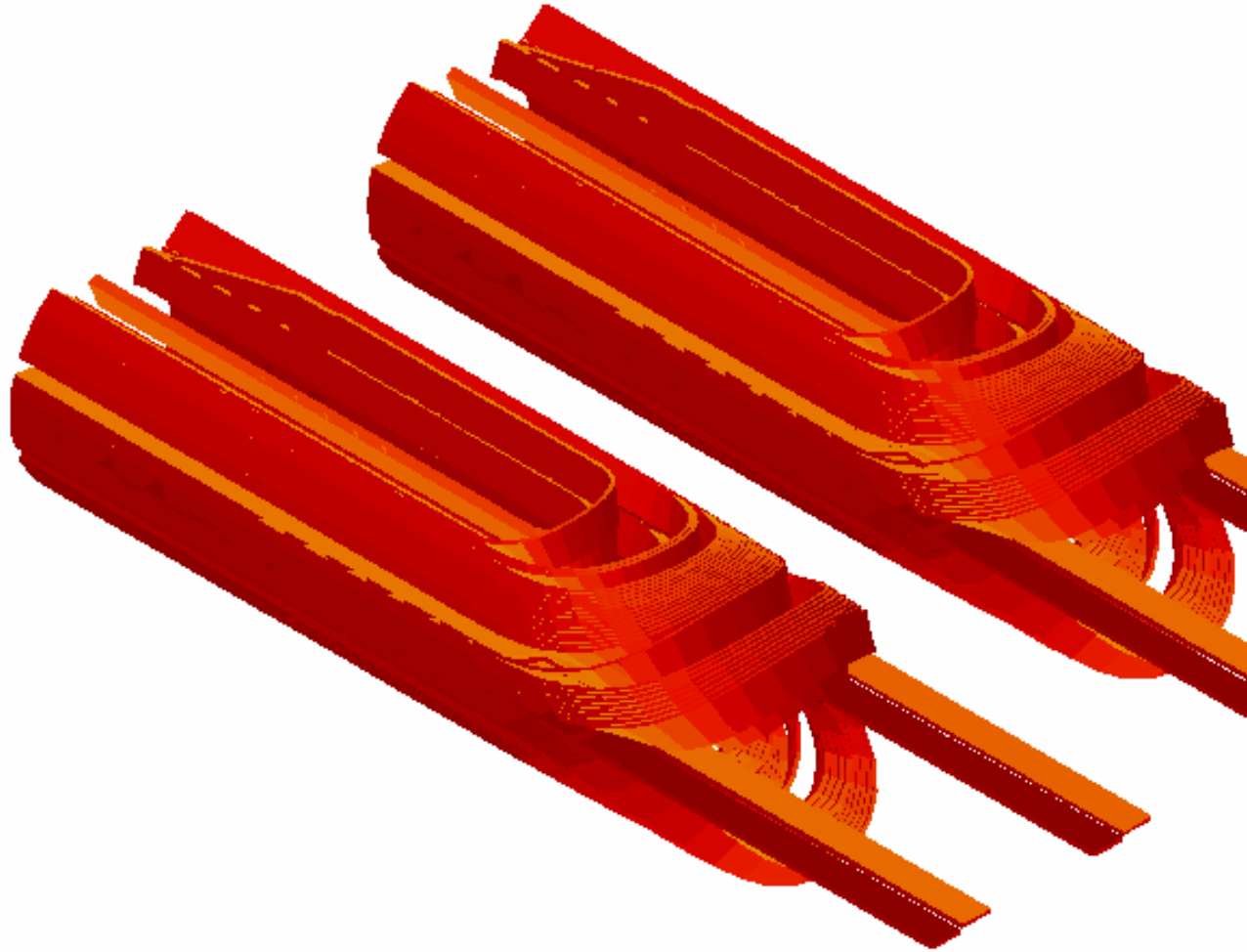

Optimization of magnet cross-section:

4) Cold bore tube and beam screen

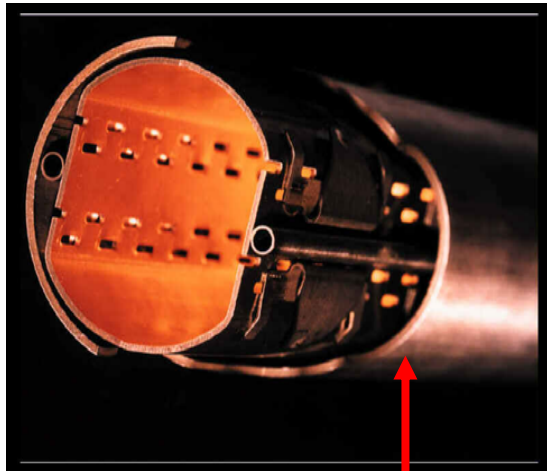

Cold bore tube: stainless steel

Insulated at CERN with a **special Insulation technique > 20 kV**

Clearance between coils and insulated CBT is only 0.5 mm over the 15 m length

CBT

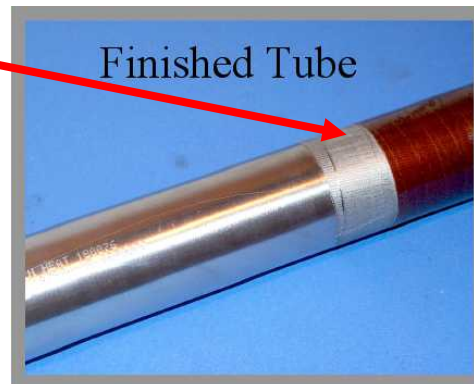

Optimization of magnet cross-section:

5) Collars

Collars are a key element of a magnet
They control prestress (mechanics)
and Field Quality

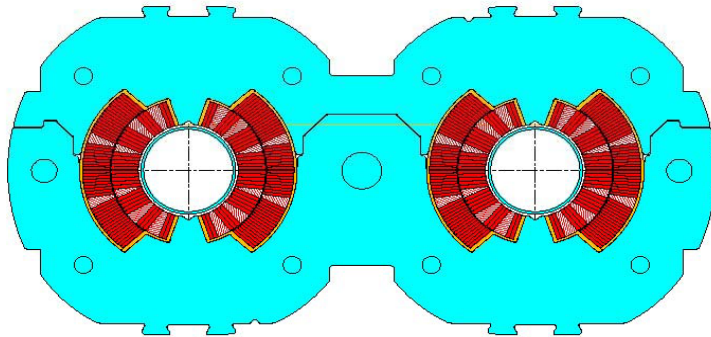

Collars and collaring define precisely the final coil shape

The collars are made of stainless steel

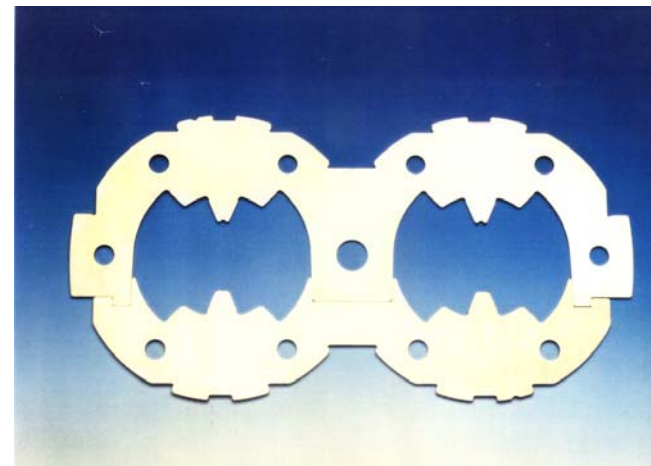
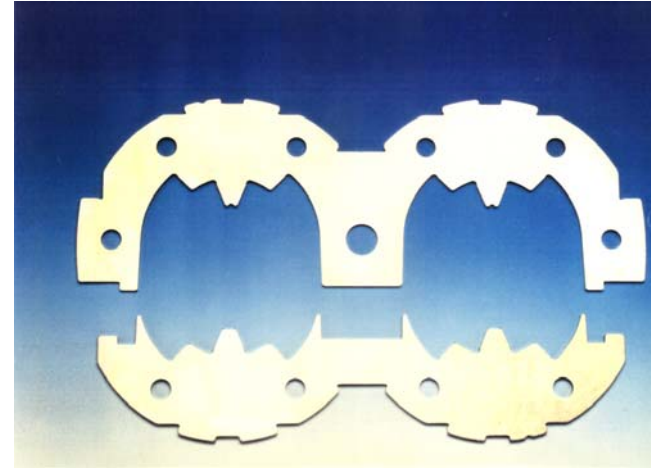

Optimization of magnet cross-section: 5) yoke laminations

One supplier for the steel 45,000 tons
Precise vertical gap

Regular *Nested*

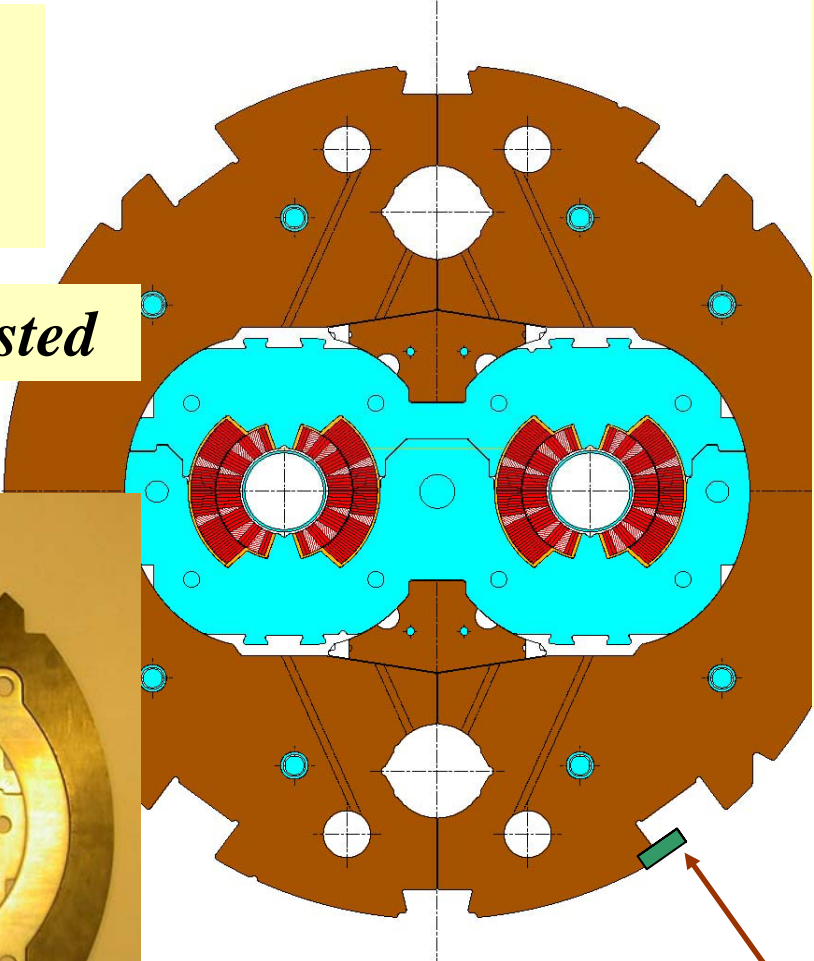
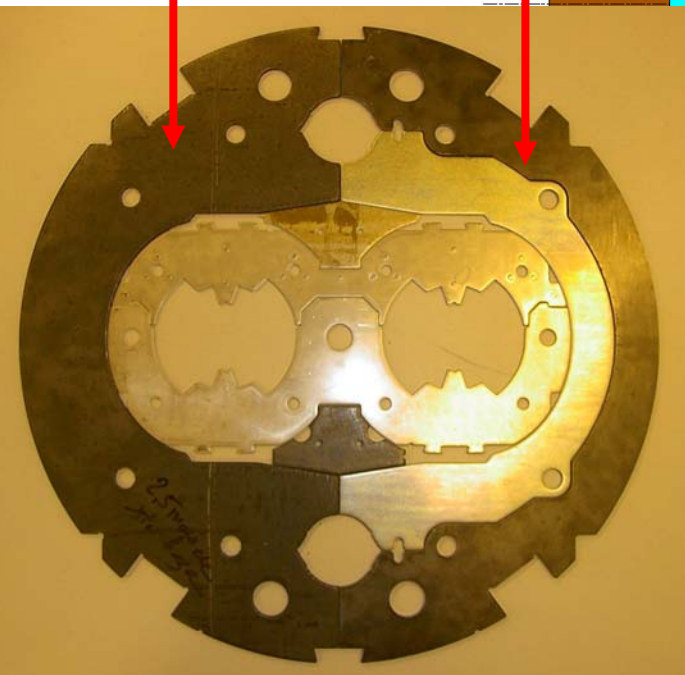

The iron yoke:
Controls stray field
~15% field increase
(but bigger gain for protection)
At saturation affects field quality (6-pole)
Used to trim length (magnetic)

Temperature probe

Optimization of magnet cross-section:

6) Shrinking cylinder and support

Two half shells,
welded on
the magnet

(Many
difficulties)

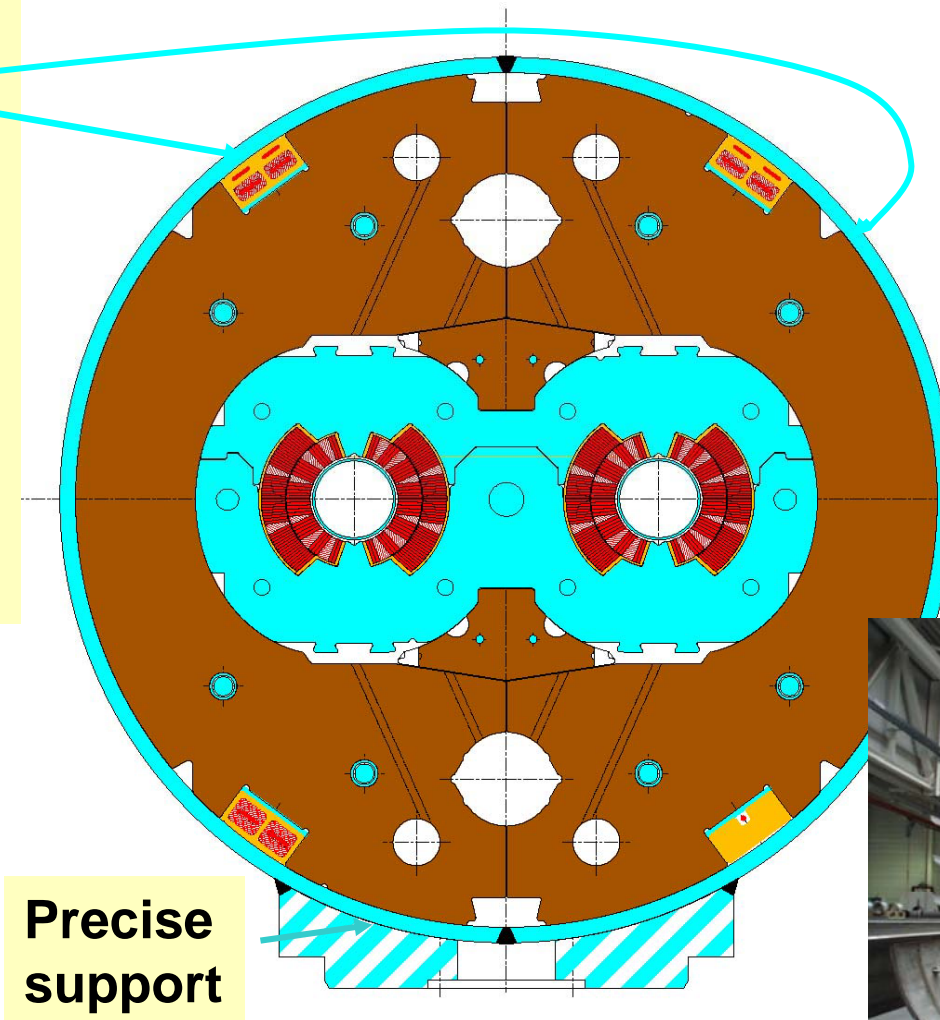

Tolerance on
curvature released
from ± 1 to ± 2.5 mm.

(But still very difficult
to achieve)



Optimization of magnet cross-section:

7) Copper heat exchanger

Saturated low pressure HeII

Copper Heat Exchanger Tubes

All voids (included coils) are filled with pressurized liquid He and cooled by heat exchange from 4.2 K down to 1.9 K

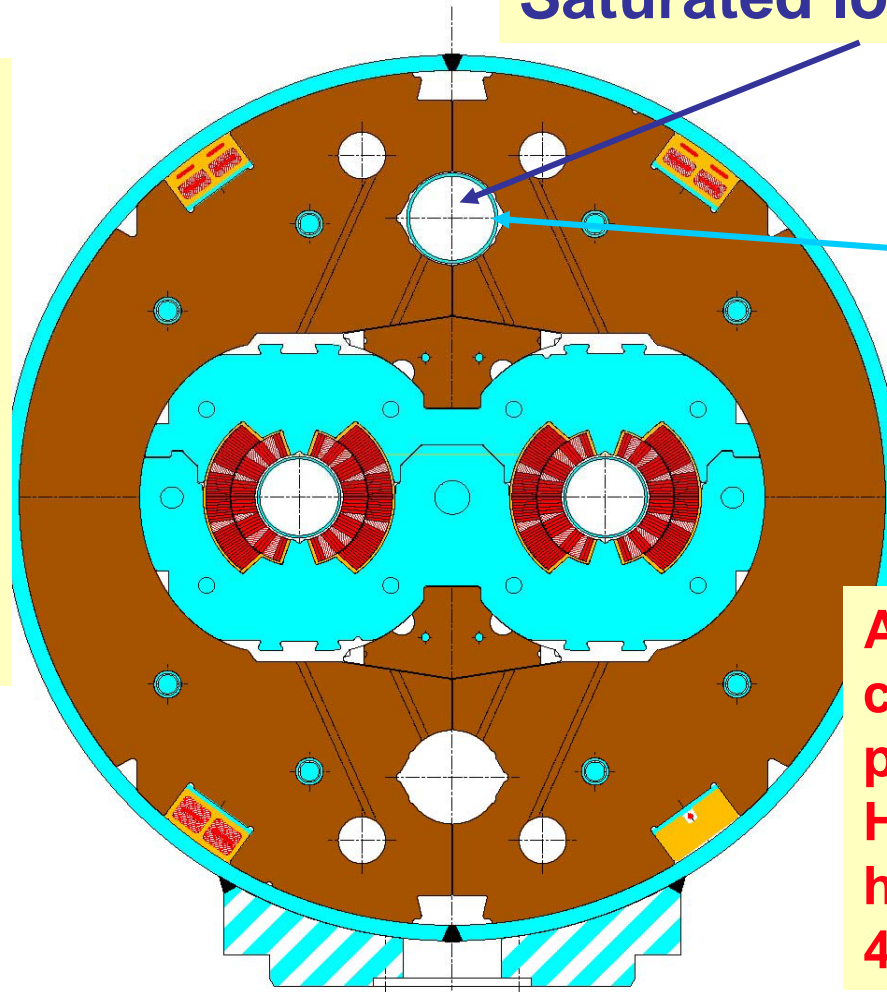

Buy Cu tubes.

All processing is done at CERN, i.e.

- Machining
- Vacuum brazing
- E-beam welding
- Cleaning

LHC main dipole - end part: shrinking cylinder

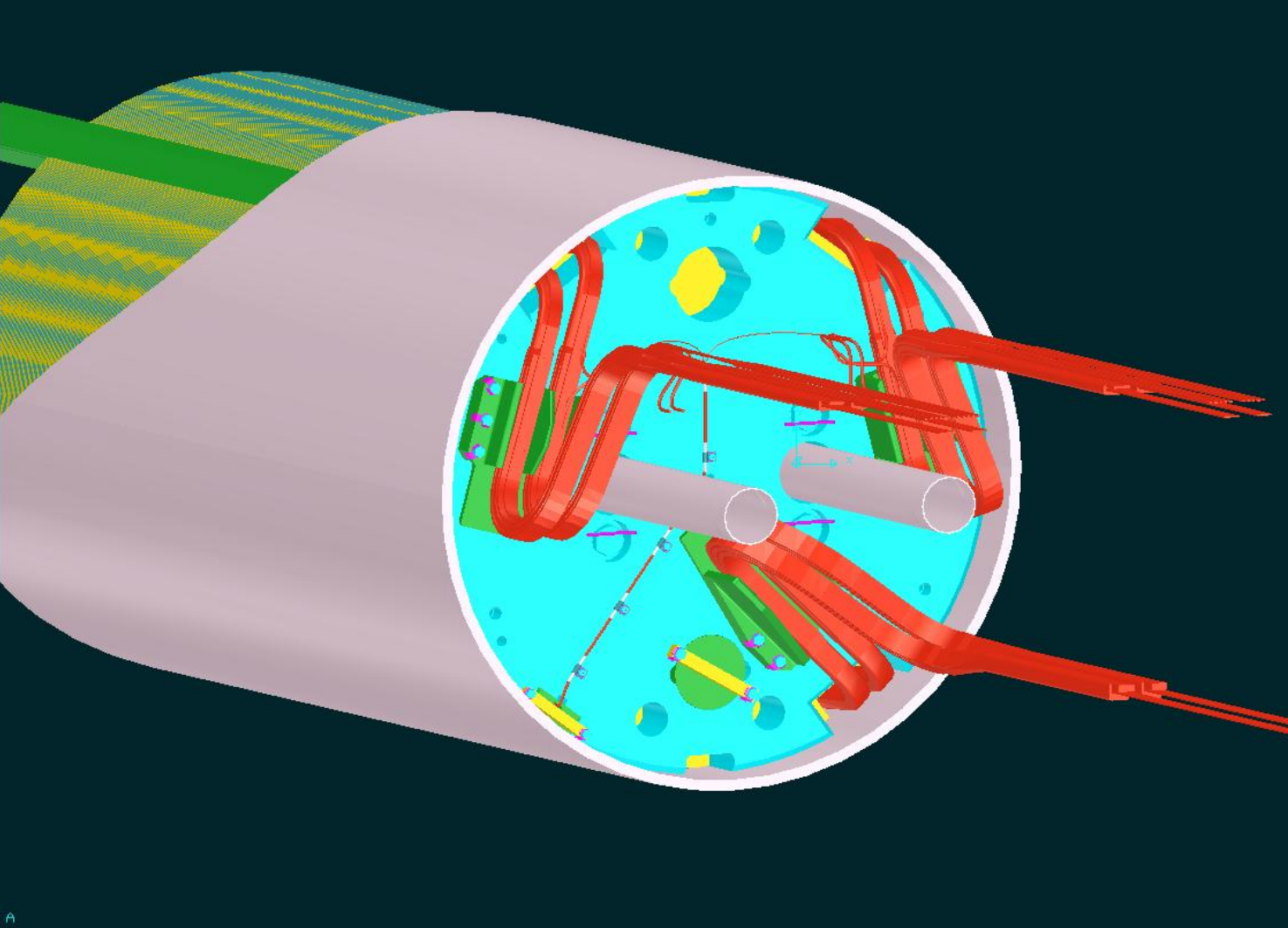

LHC main dipole - end part: Foot, Bellows and Line-N

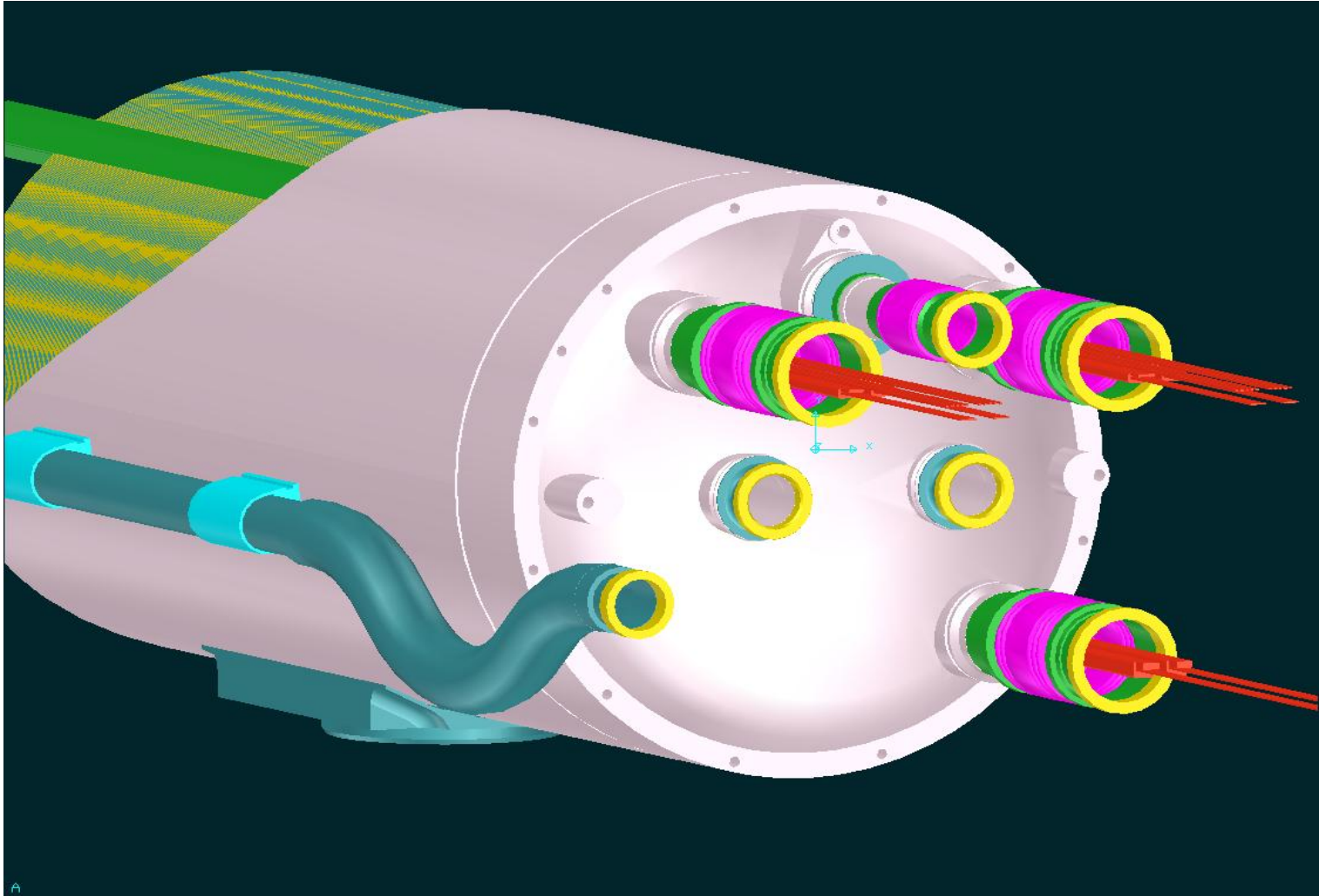

Interconnection between two SC magnets

6 superconducting bus bars 13 kA for B, QD, QF quadrupole

20 superconducting bus bars 600 A for corrector magnets (minimise dipole field harmonics)

13 kA Protection diode

42 sc bus bars 600 A for corrector magnets (chromaticity, tune, etc....) + 12 sc bus bars for 6 kA (special quadrupoles)

To be connected:

- Beam tubes
- Pipes for helium
- Cryostat
- Thermal shields
- Vacuum vessel
- Superconducting cables

Snapshots of industry



Superconducting Magnets
Summer 2006 Tom Taylor

Logistics and quality assurance: another aspect of the work

- We will have put 50,000 tons of equipment in the tunnel
- We will have moved some 150,000 tons around Europe, during the last four years.
~10000 TIR, \Rightarrow 10 TIR/days in average! \Rightarrow *Paperwork !*
- Timing! We have been supplying many components...
- **QA : The MTF Manufacturing Test Folder**
Full description of the magnets: some 500 entries !
It assures the full and permanent traceability
It also includes records of all non-conformities

What's special in Detector Magnets

- Historically detector magnets were the **first major application of superconductivity** (Bubble Chambers)
As early as late 60s and beginning of 70s big magnet in LHe pool, boiling: Argonne and BEBC (CERN);
concept of **cryostabilisation (Stekly criterion)**
- **Pure aluminum as stabilizer** was initially employed for thin solenoids; then also for other solenoids, and now toroids. It is now the standard stabilizer.
- **Large margin** to be stable against large perturbation.
- **Indirect cooling** (possible for practically constant field) makes for a big simplification in the cryogenics

SC Solenoids for Detectors

The work-horse of superconducting spectrometer magnets is without doubt the solenoid. Why ?

1. Because of the **small ratio of peak / working field**, the geometry of a solenoid is ideally suited for superconductivity
2. Cylindrical winding shape => **ease of manufacture**
3. Main electro-magnetic forces are taken within the cold mass as hoop stress => **easy to optimize** mechanically + **low heat in-leak**
4. Winding can be inserted into the cylinder that is required for longitudinal support, and which can in turn be cooled with helium flowing in simple pipework => **good thermal contact** improves as field increases and the conductor to push against the wall
5. Can be made **thin** => **transparency** makes for versatility
6. Long and varied **experience** can be exploited => cost control

ATLAS Central Solenoid (CS)

This 2 T solenoid, designed by KEK, is the most transparent (X/BL^2) ever built. \varnothing 2.5 m, 5 m long.

It features a newly developed high-strength stabilizing alloy

It is already installed and tested

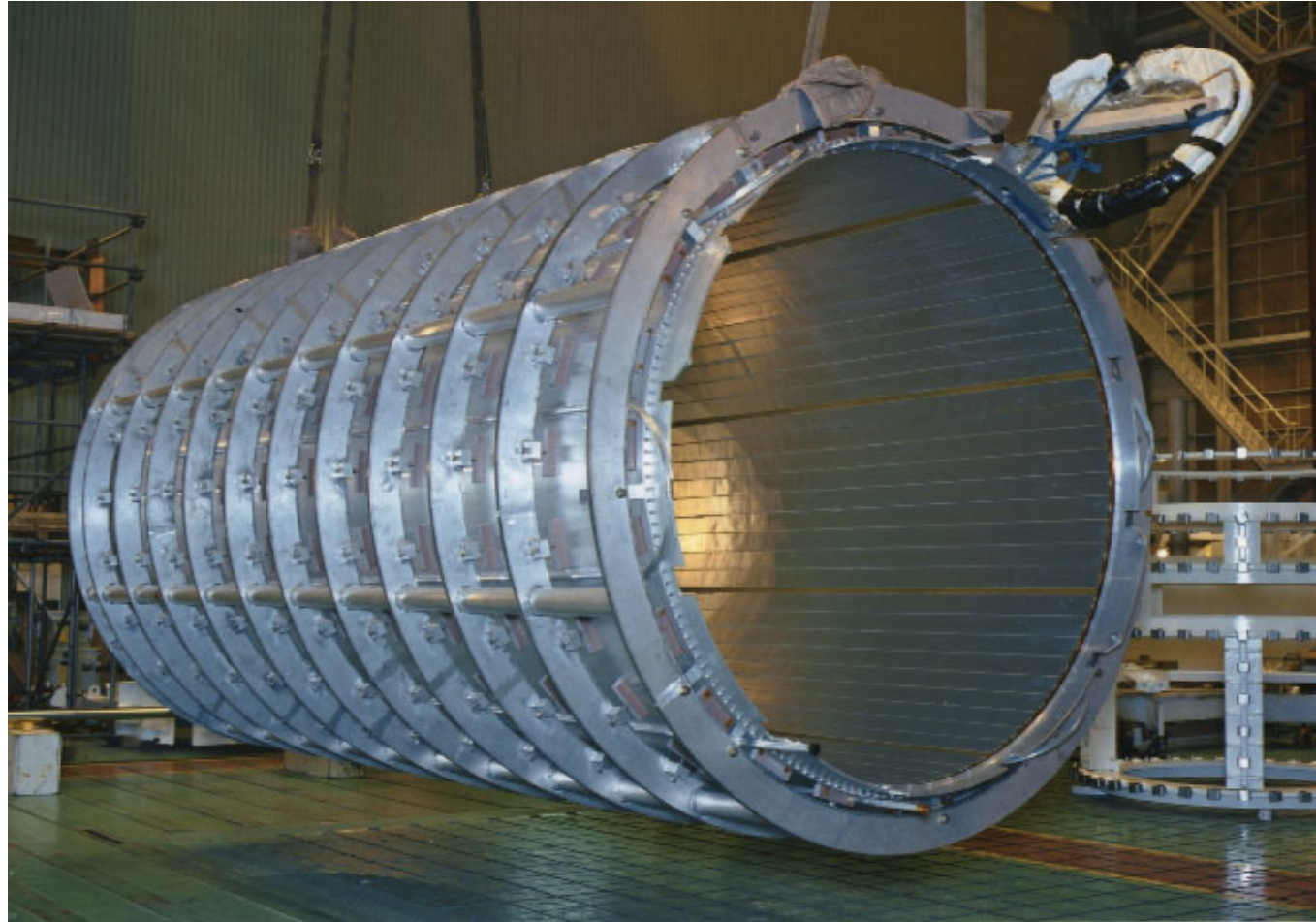

Cross section of aluminum stabilized superconductor

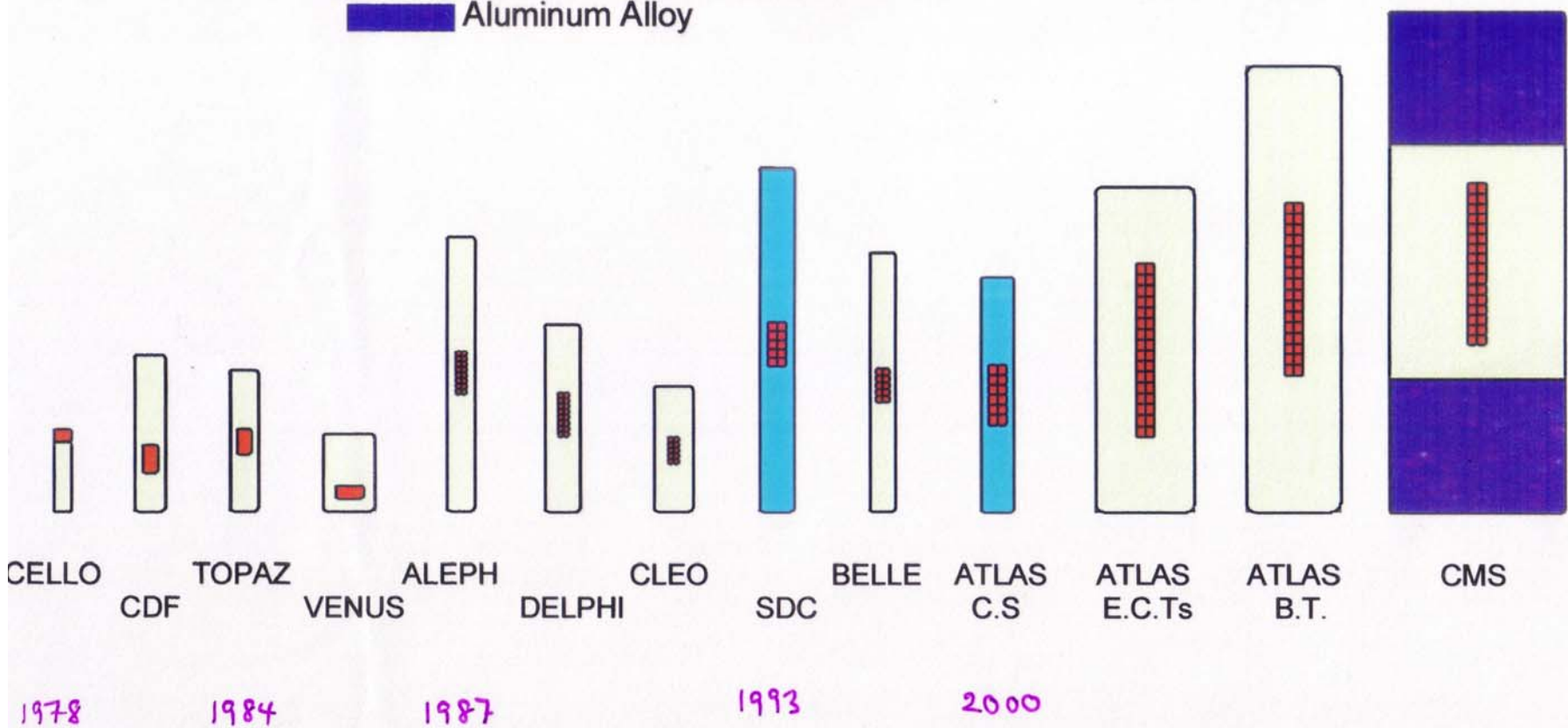
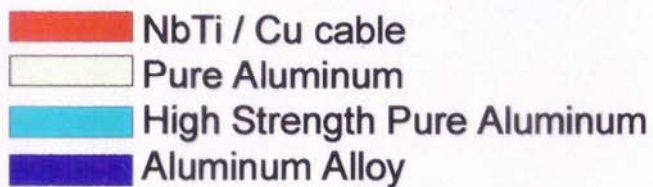

Coil Winding

Pre-winding

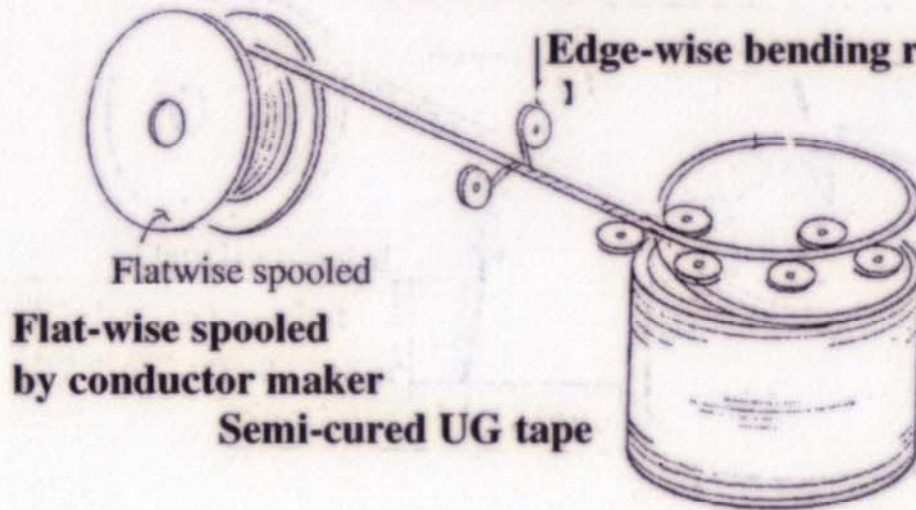

Pre-formed by using a series of bending rollers to have the same radius as the coil (after insulation)

Winding the coil inside the support cylinder

Pre-wound coil

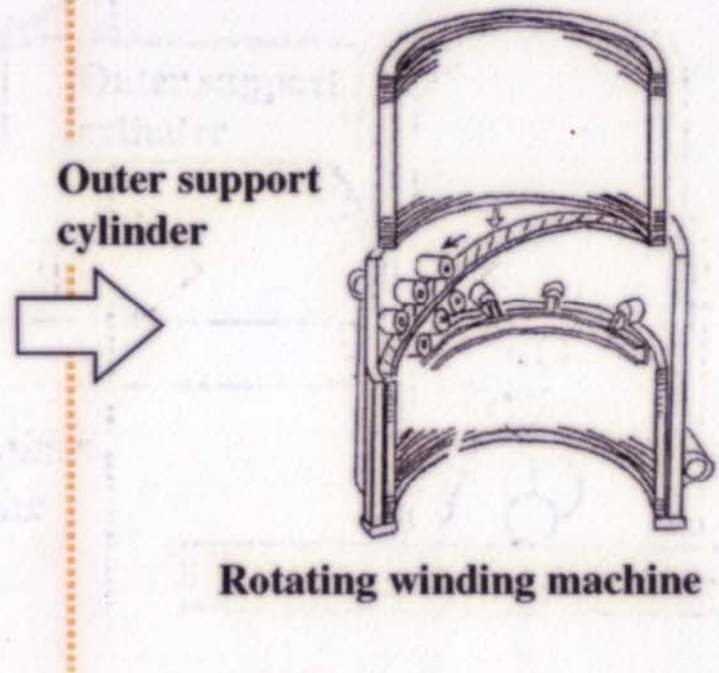

Coil Design

Challenge for coil thickness to be $\sim 1/3$
and totally $\sim 1/2$ including cryostat

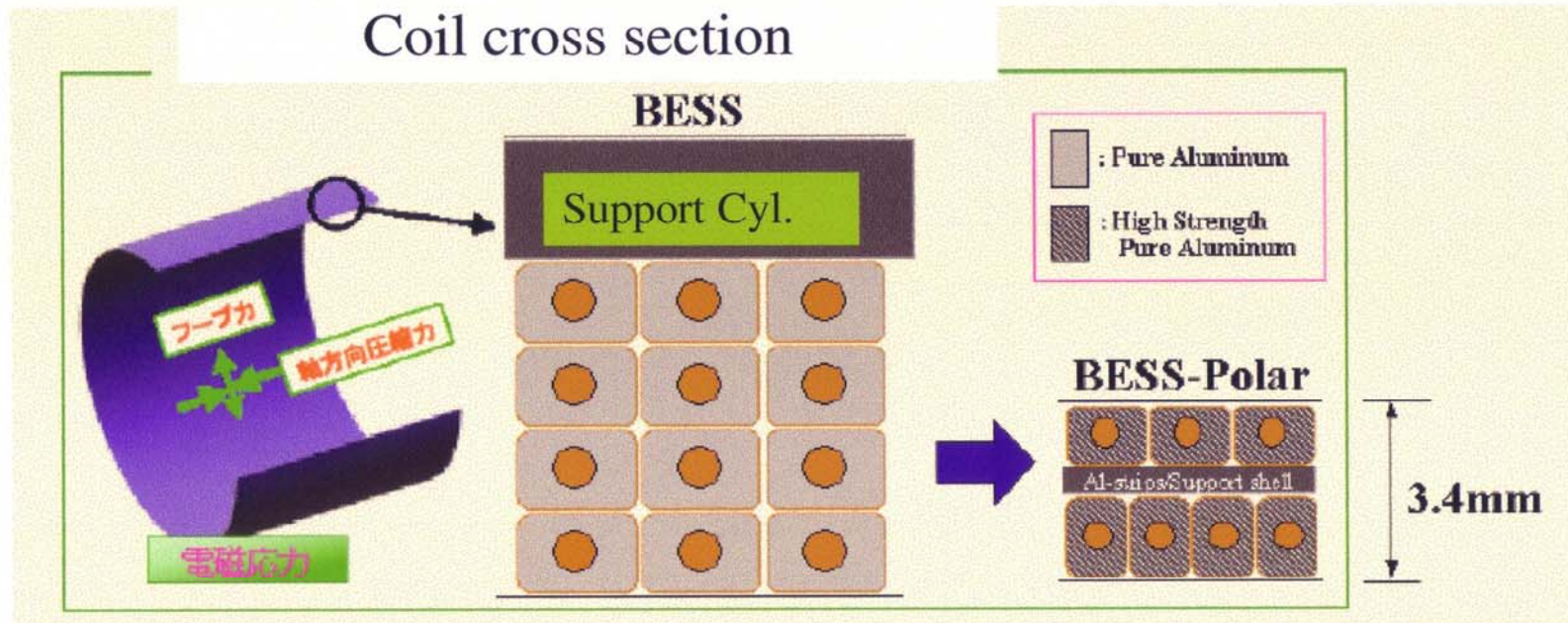

Full Dia. Model #1 (in 1/7 length)

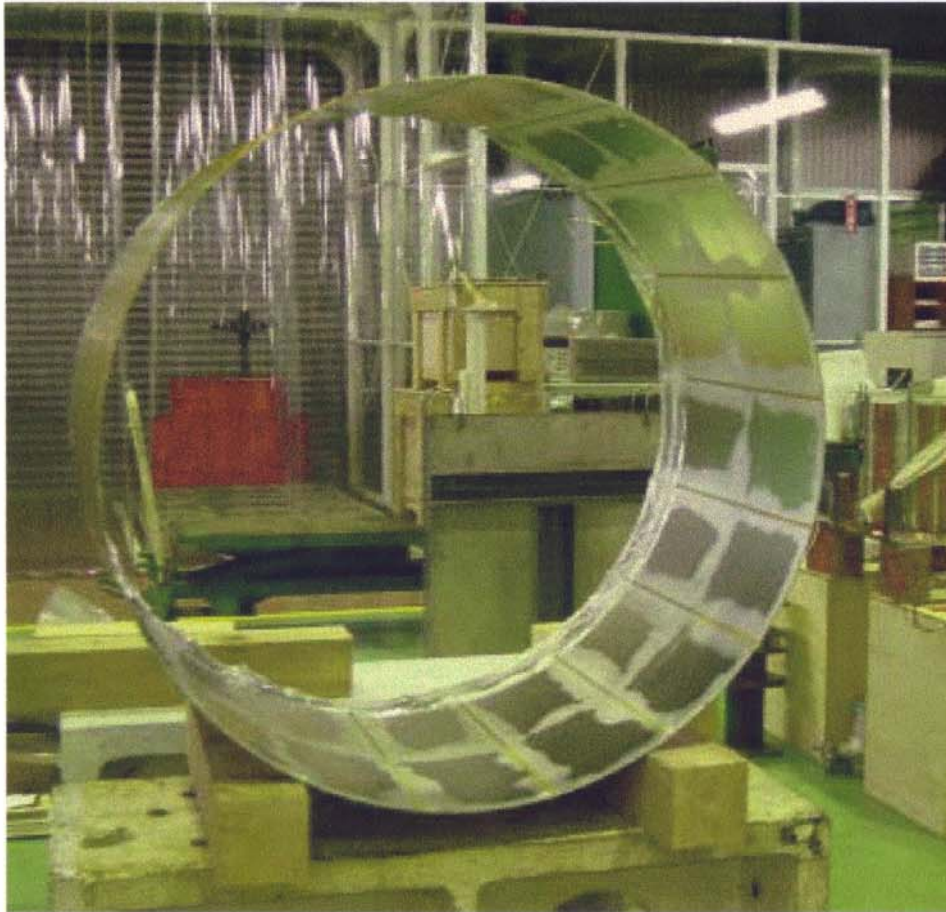

Thickness: 3.3 mm

**Material: $\sim 1 \text{ g/cm}^2$
($\sim 1\text{-cm}$ thick Scintillator!)**

BESS-Polar magnet – ultra-thin solenoid

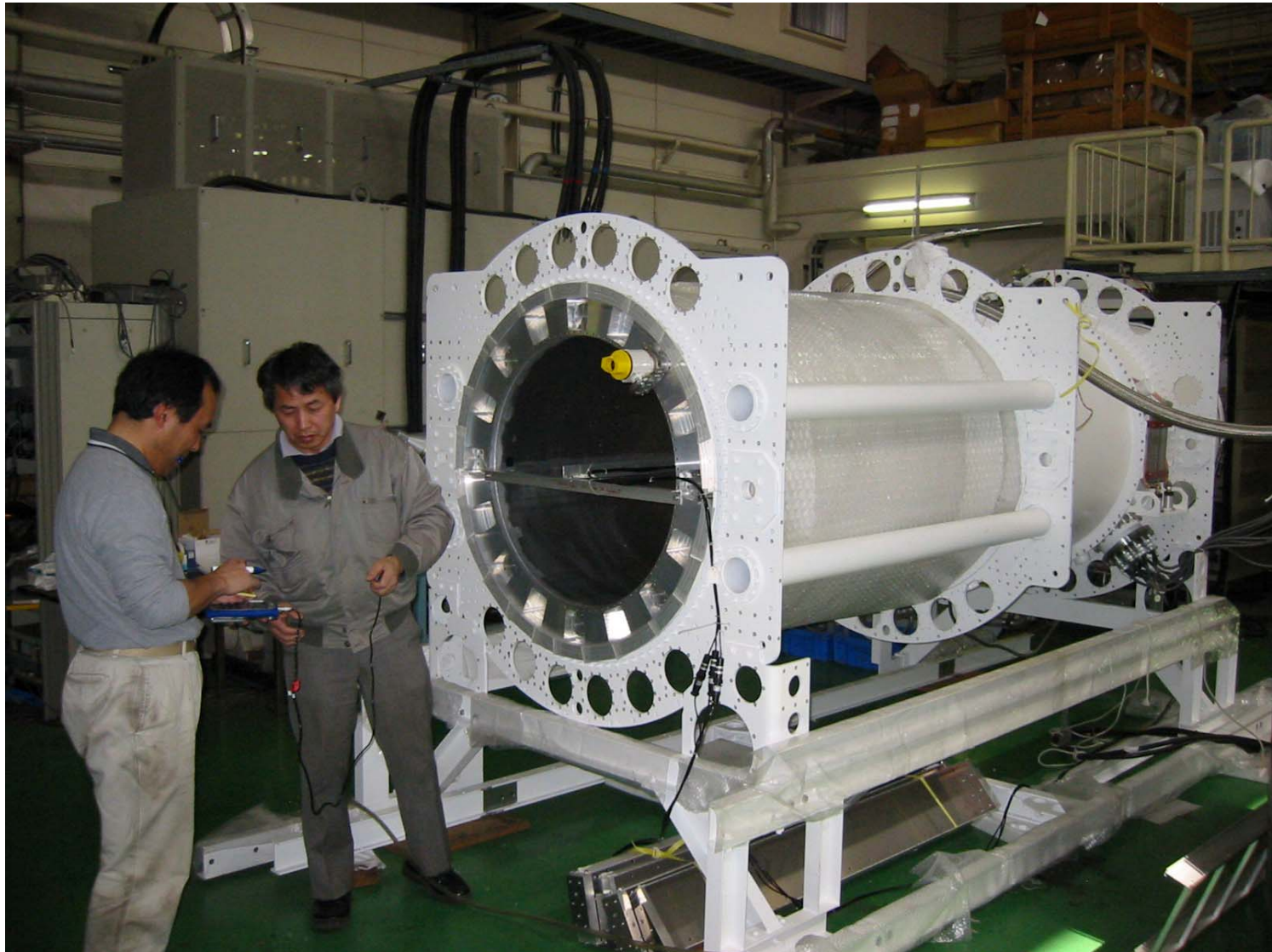

Superconducting Magnets
Summer 2006 Tom Taylor

The Solenoid for the CMS experiment

The **4 T** solenoid for the CMS (Compact(!) Muon Solenoid) experiment will be the most powerful coil ever built!

$\varnothing 7$ m, $L = 13$ m, $E = 2.5$ GJ

It features a **4-layer coil**, wound from a specially developed conductor that has been reinforced to take the large hoop stresses.

The five coil modules are each as large as can be transported by road.

The magnet has been assembled at CERN and tests will start next week.

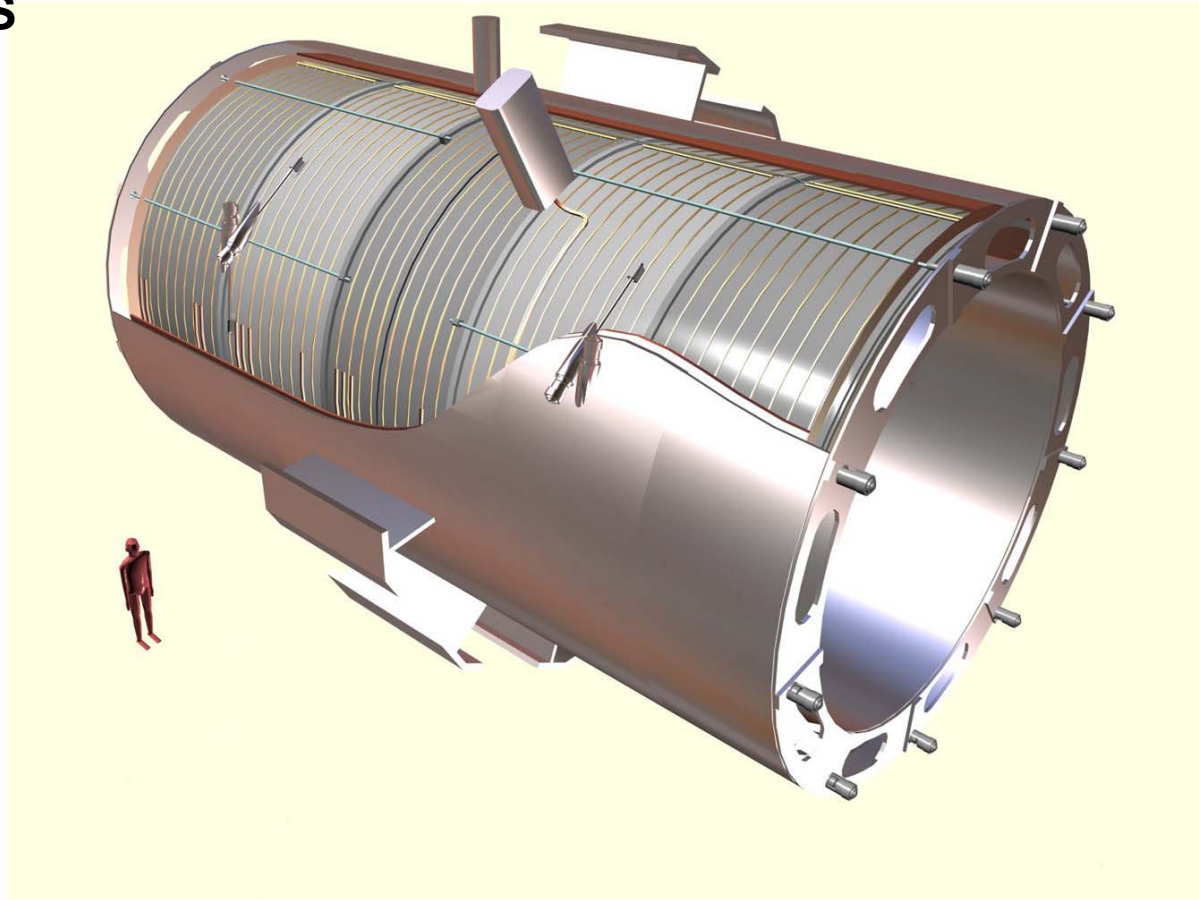

The CMS conductor

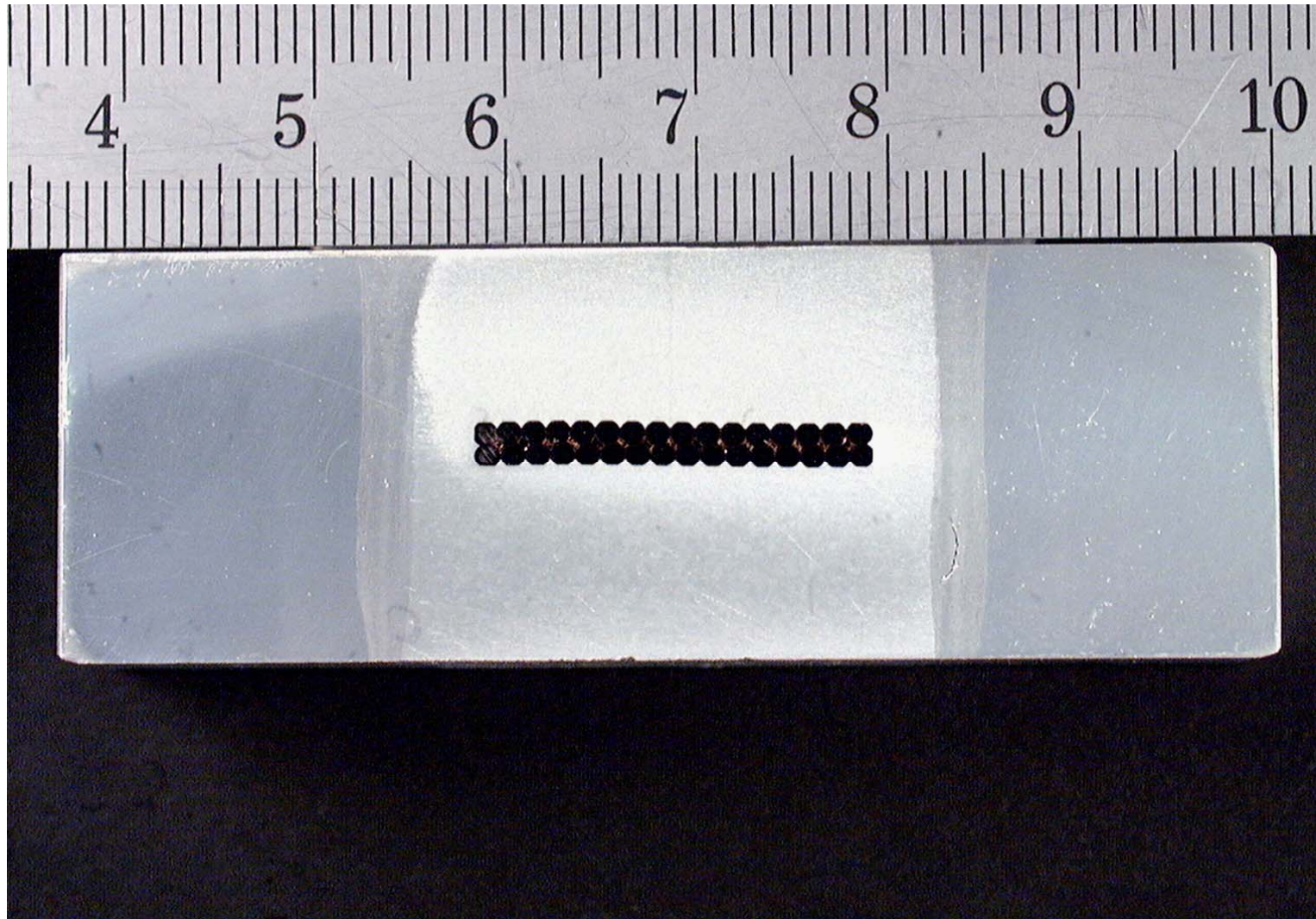



Cross-section of the CMS coil

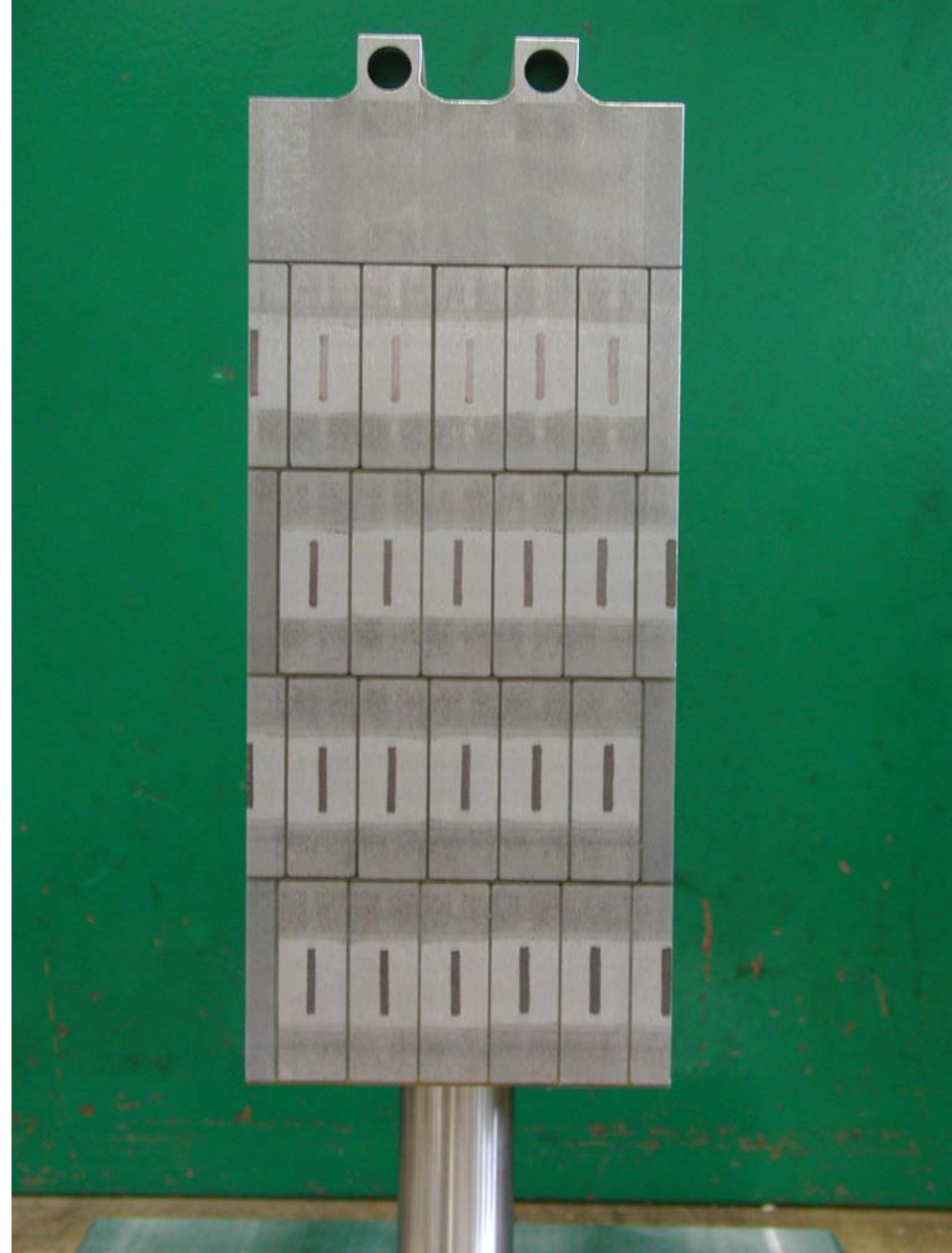

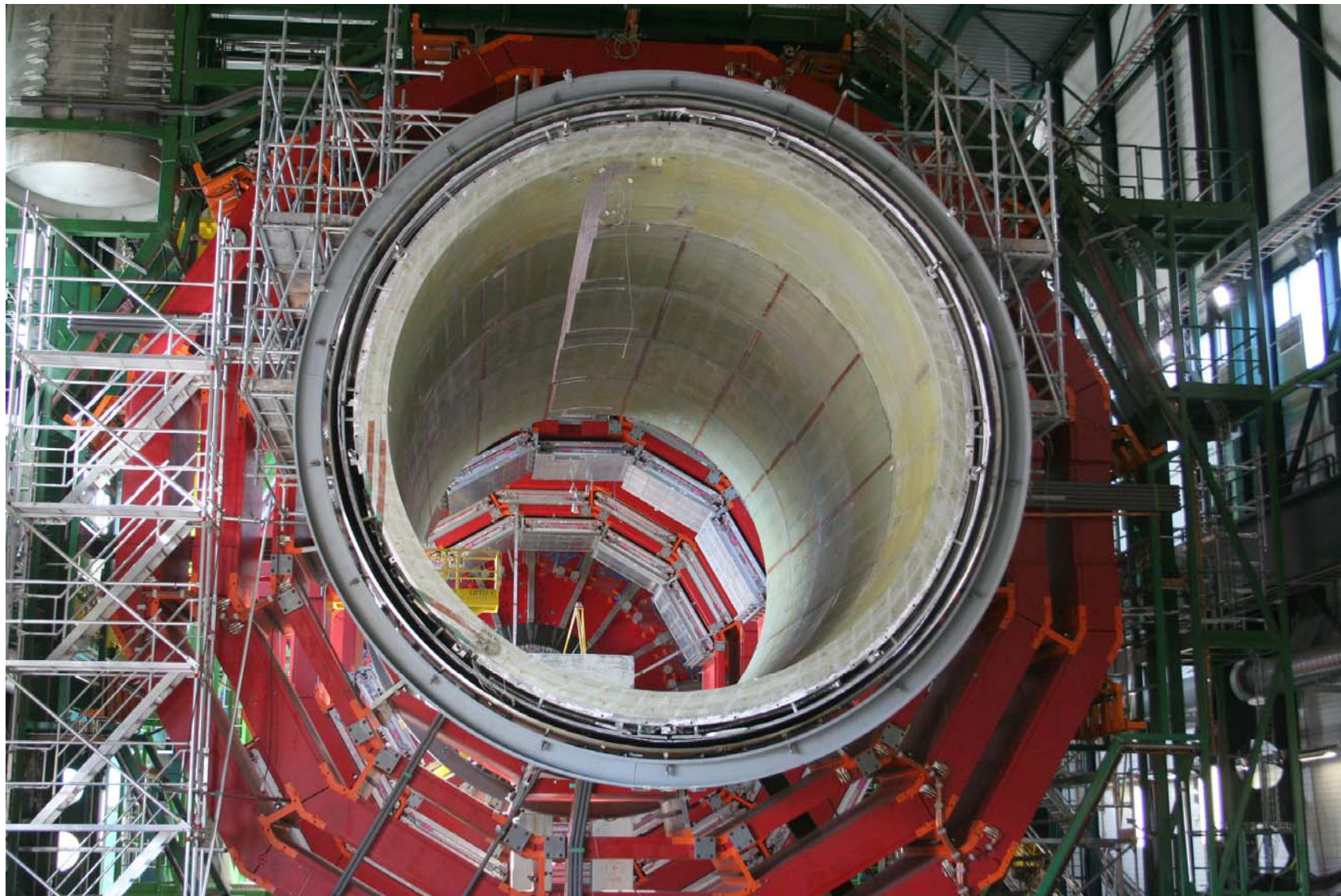

Superconducting Magnets
Summer 2006 Tom Taylor

**CMS magnet
assembled vertically
prior to swiveling**



Superconducting Toroids for detectors

- Superconducting, air-cored, toroids have always fascinated physicists...
- Why? **Field is always perpendicular to particle trajectory**. *Clean concept*
- **Closed field, no iron yoke** for flux return; => zero magnetic moment
- **Zero-field along the beam**

BUT

- $B \sim R^{-1}$: $B_{av}/B_{peak} \cong 0.25$
(for solenoids $\cong 0.75$)
- Forces are **not self-sustaining**
(in a solenoid, force => hoop stress)
- Inner coil runs interfere with tracks

*Less than ideal for superconductivity...
(and for physics too?)*

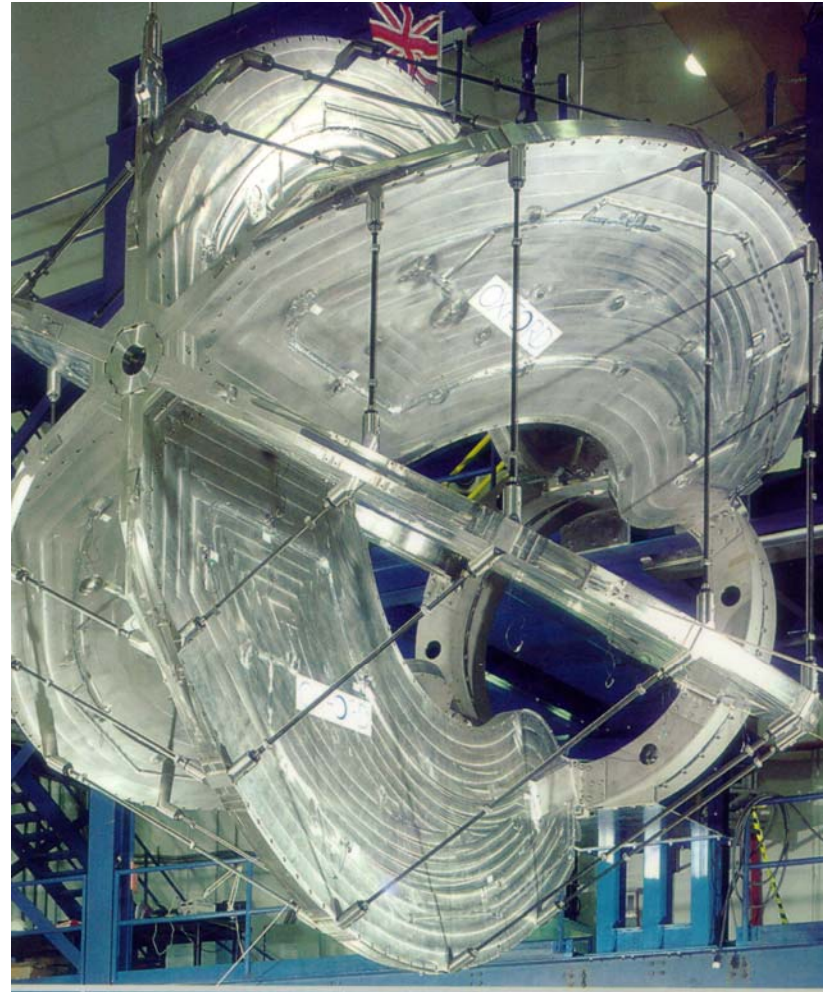

Air core Torus for an experiment at CEBAF
(Courtesy of Oxford Superconductivity)

The Challenge that is ATLAS

- ATLAS is the largest complex SC magnet system in construction
4 large magnets
- Barrel Toroid (BT)
 \varnothing_{out} **21 m** and $L =$ **26 m**
 $B_{\text{peak}} \sim 4 \text{ T}$, $E = 1.5 \text{ GJ}$
- End-Cap Toroids (ECT)
(2) enclosed coil sets
- Central Solenoid (CS)
Thin, $\varnothing_{\text{coil}}$ **2.5 m**, 2 T
- CEA-Saclay, CERN, KEK, INFN-LASA, NIKHEF, RAL and CERN are all involved in the work (and cost!)

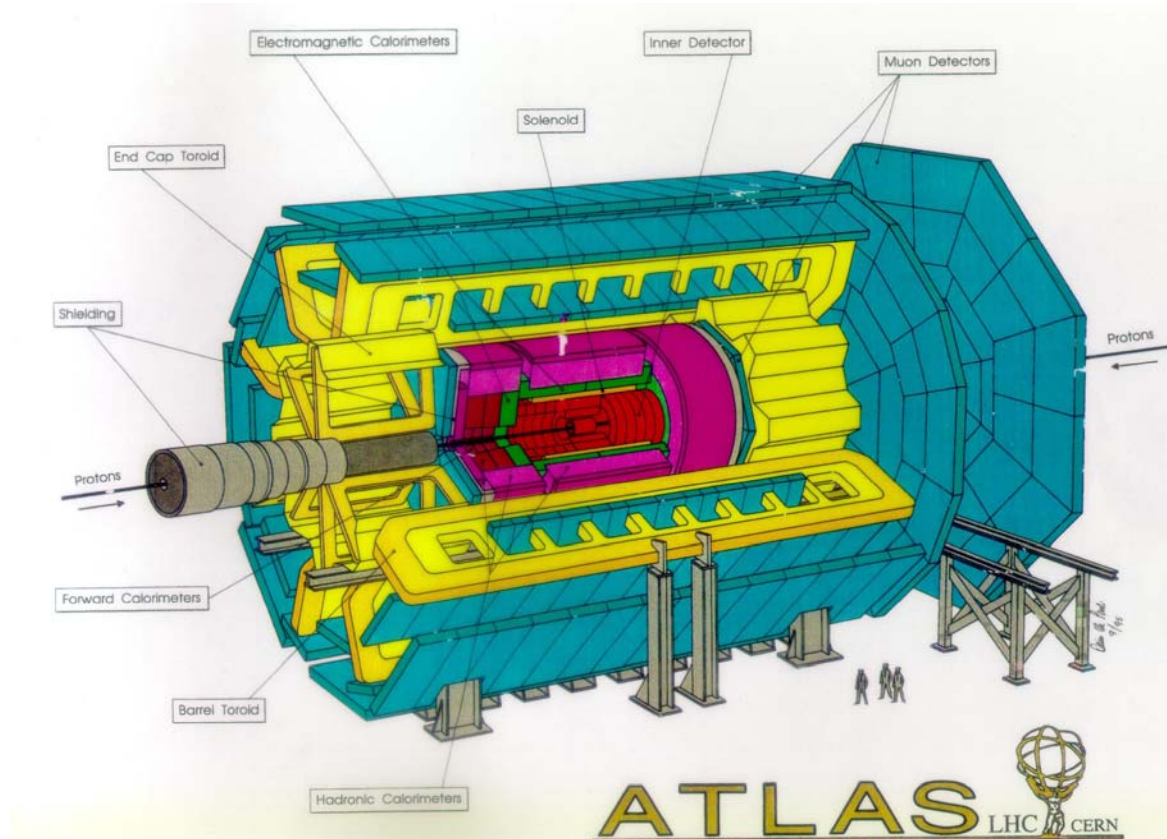

ATLAS Superconducting Magnet System

Barrel Toroid + End Cap Toroids + Central Solenoid

- System of **4 magnets** provides magnetic field for the inner detector (solenoid) and muon detectors (toroids)
- 20 m diameter x 25 m long
- **8200 m³ volume**
- **170 t superconductor**
- **700 t cold mass**
- **1320 t total mass**
- **90 km superconductor**
- **20.5 kA at 4.1 T**
- **1.55 GJ stored energy**
- conduction cooled at **4.8 K**
- **8 years construction 98-06**



Detector characteristics	
Width:	44m
Diameter:	22m
Weight:	7000t

CERN AC - ATLAS V1997

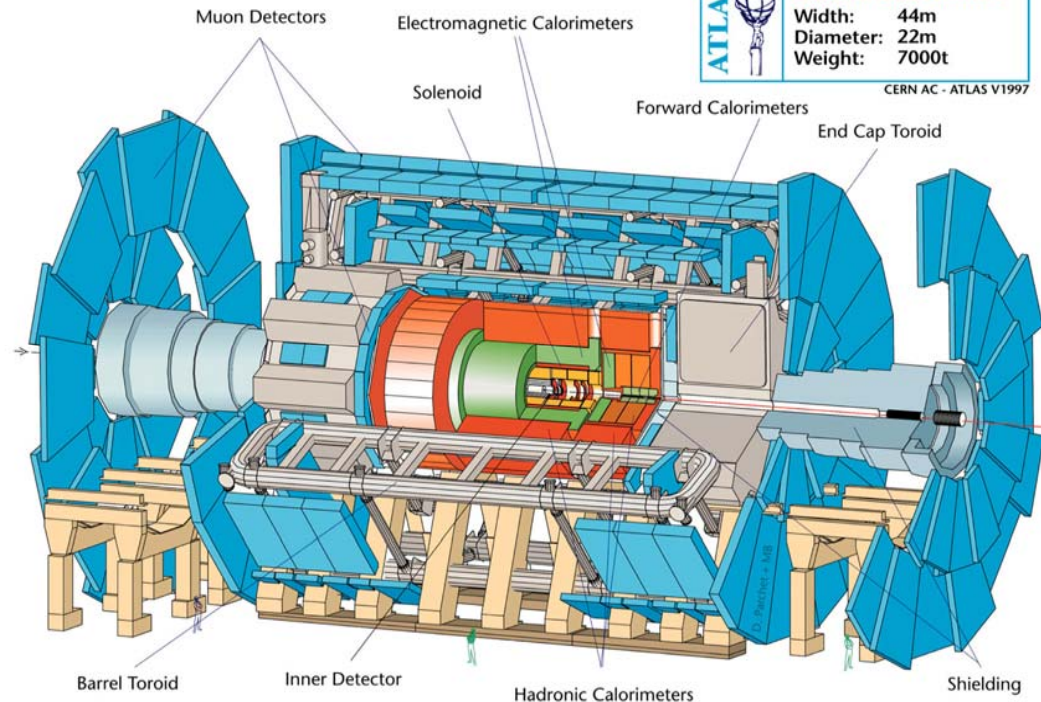

– **Actually it is the largest superconducting magnet in the world !**

Barrel Toroid

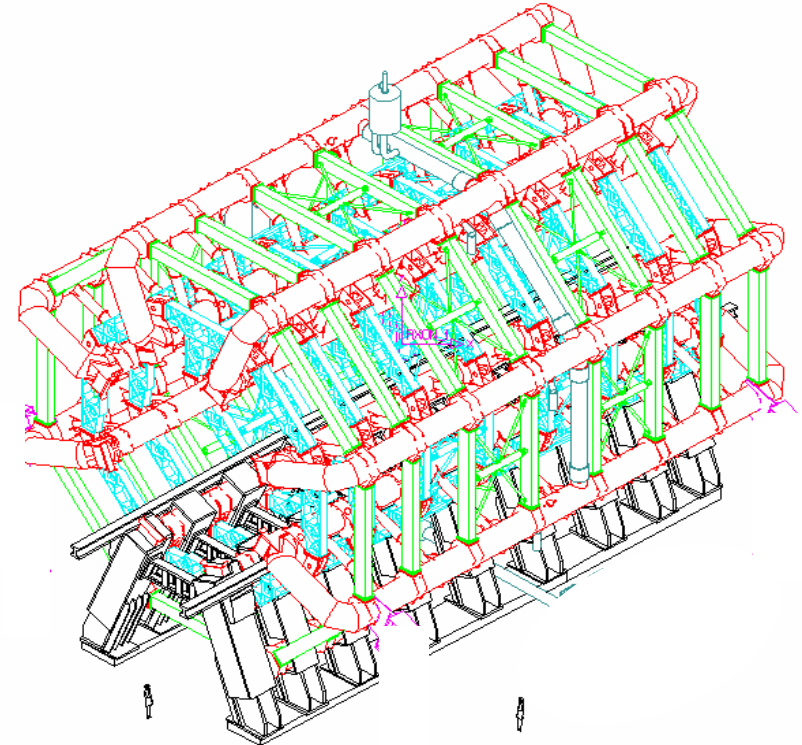

- **Integration of the last coil completed in June**
- **All coil past the tests and were accepted for installation**
- **Last coil transported to point 1 by end of July**
- **Last coil installed on 26 Aug (see report of Tuesday morning by Michel Raymond)**
- **Next steps : complete installation and connect all services necessary to operate the toroid:
vacuum, cryogenics, current, controls & safety systems**

The Barrel Toroid being assembled

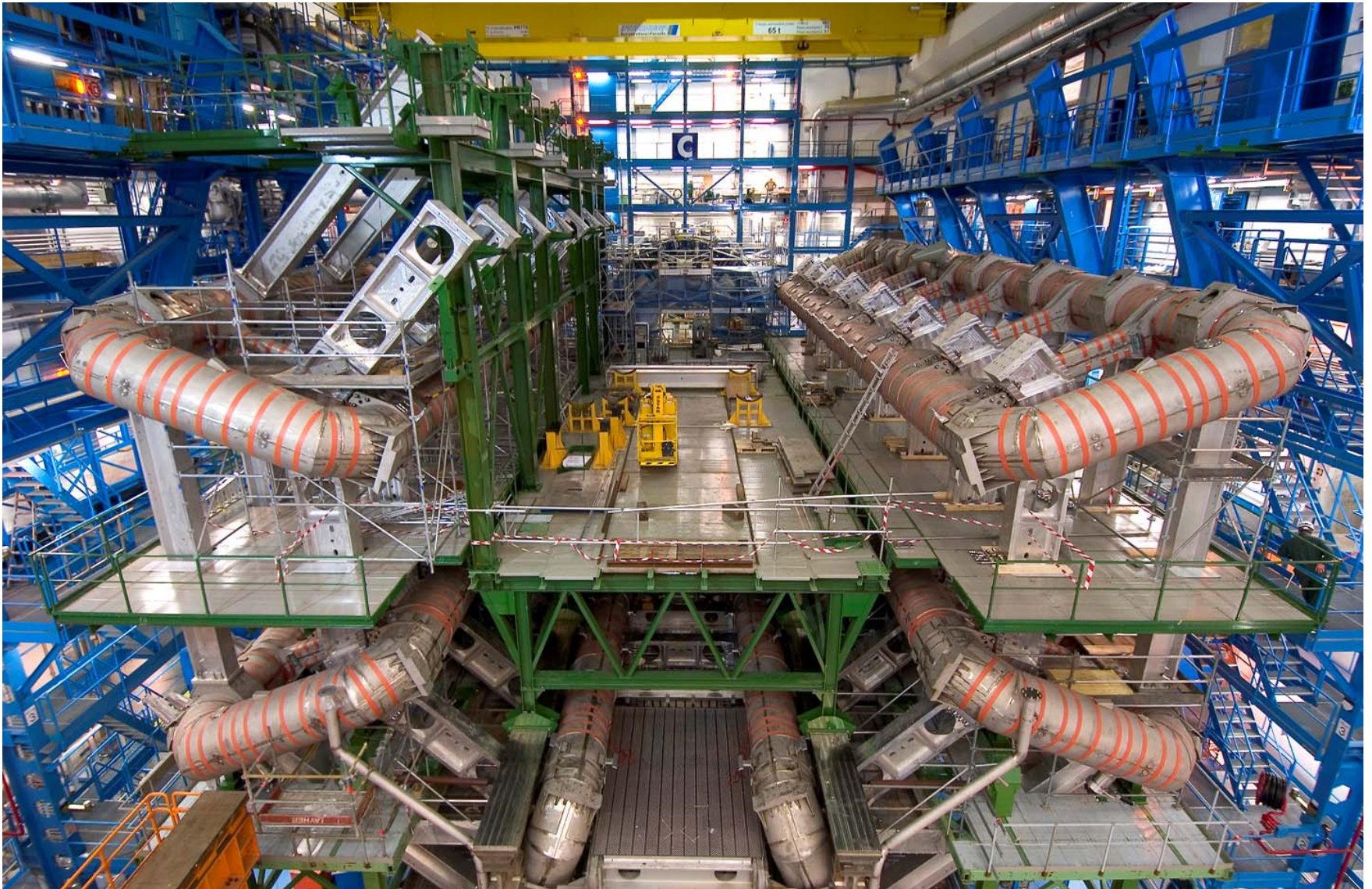

Superconducting Magnets
Summer 2006 Tom Taylor

Barrel Toroid shape

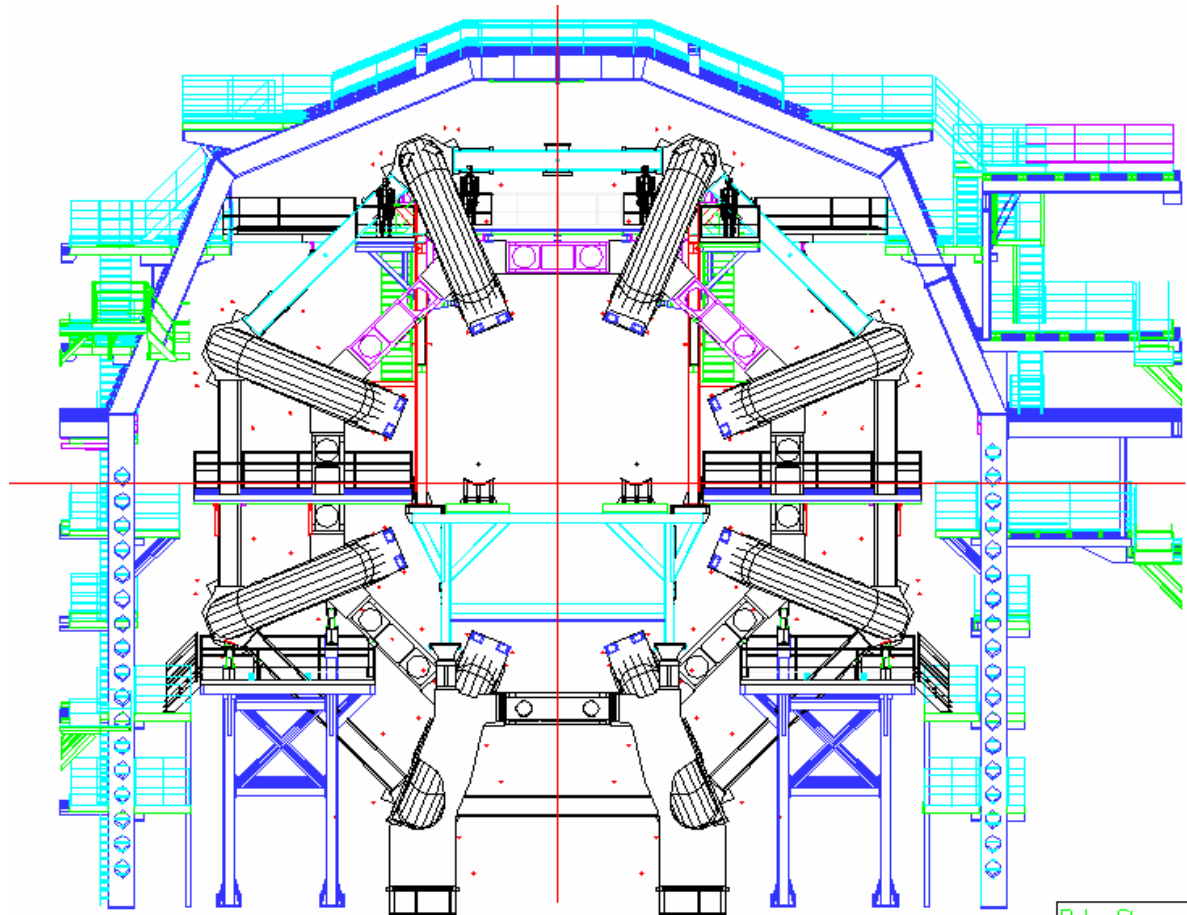

- **BT release of supports completed**, sag=18mm (830 tons)
- With 350 tons extra muon chambers and services **24-26mm**
- 30mm pre-shaped, thus +5mm, **Perfect and as calculated!**

Proximity Services

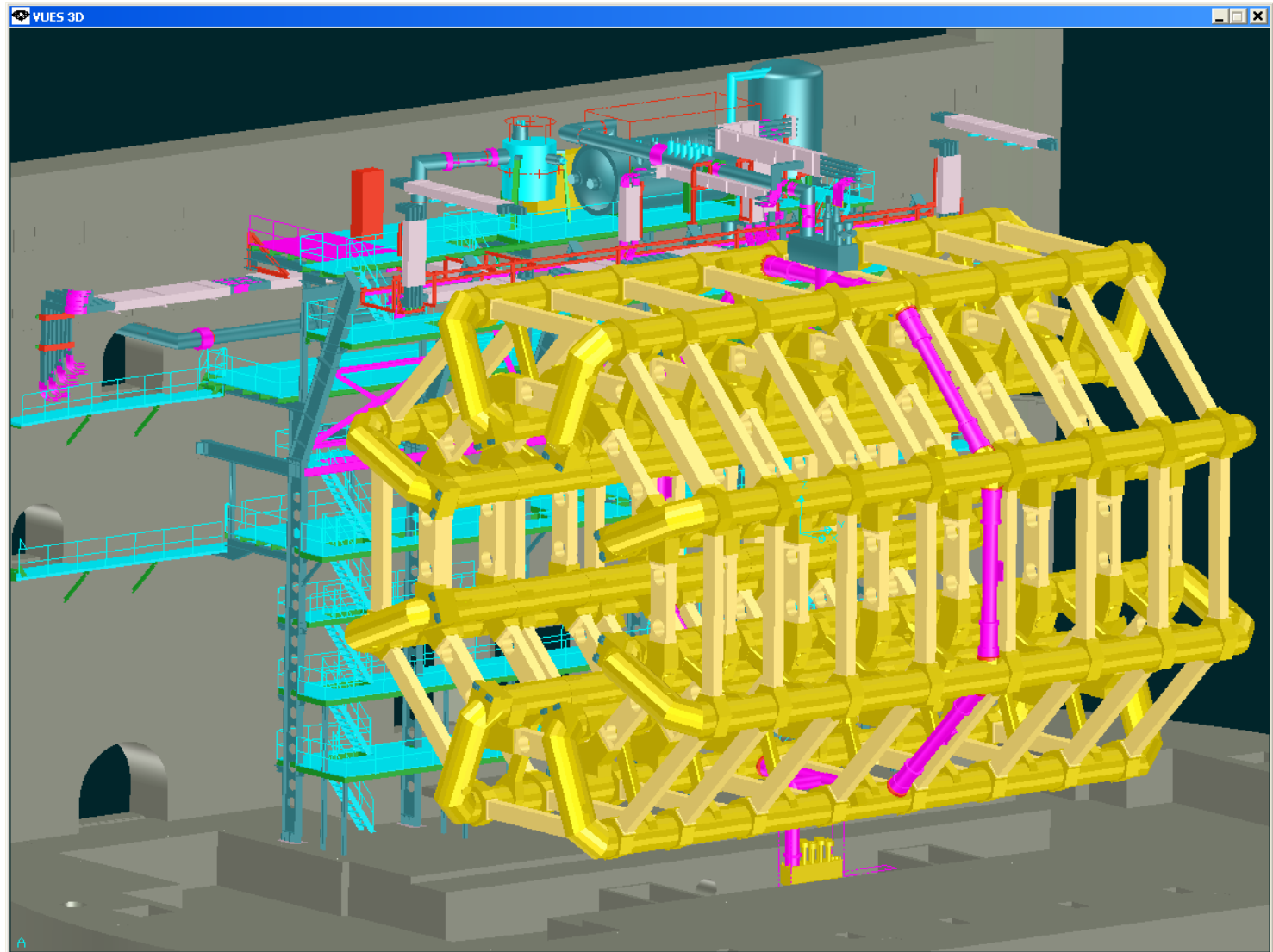

End Cap Toroids

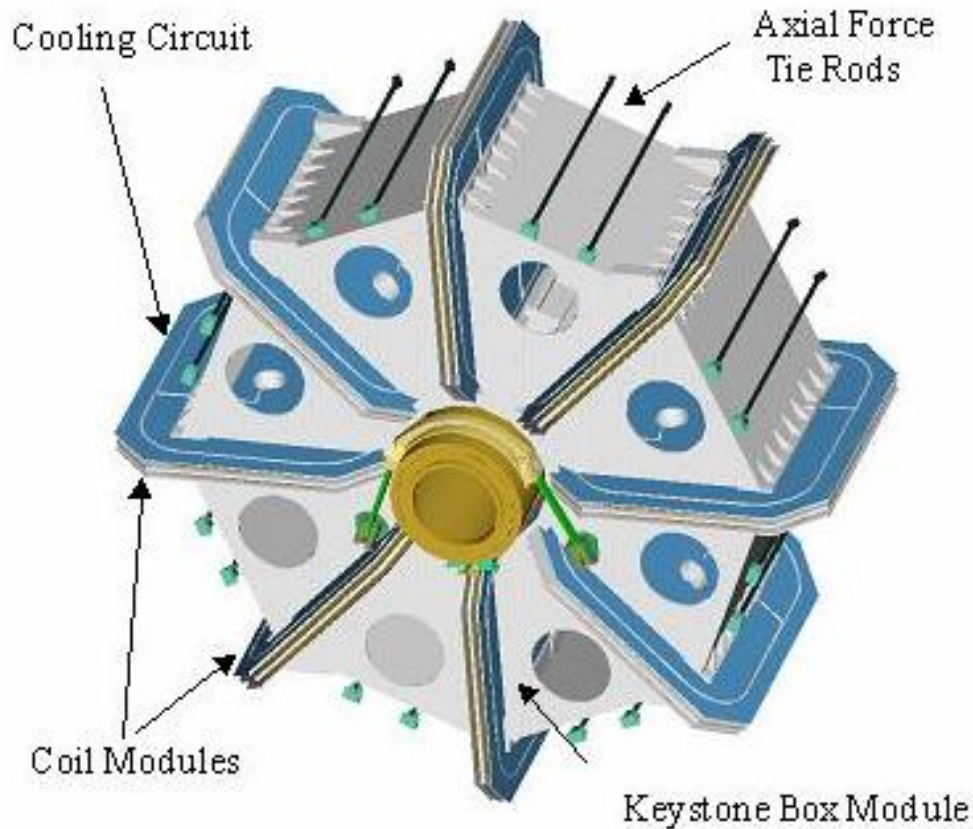

ECT Cold mass



ECT Vacuum Vessel



The MECO Apparatus

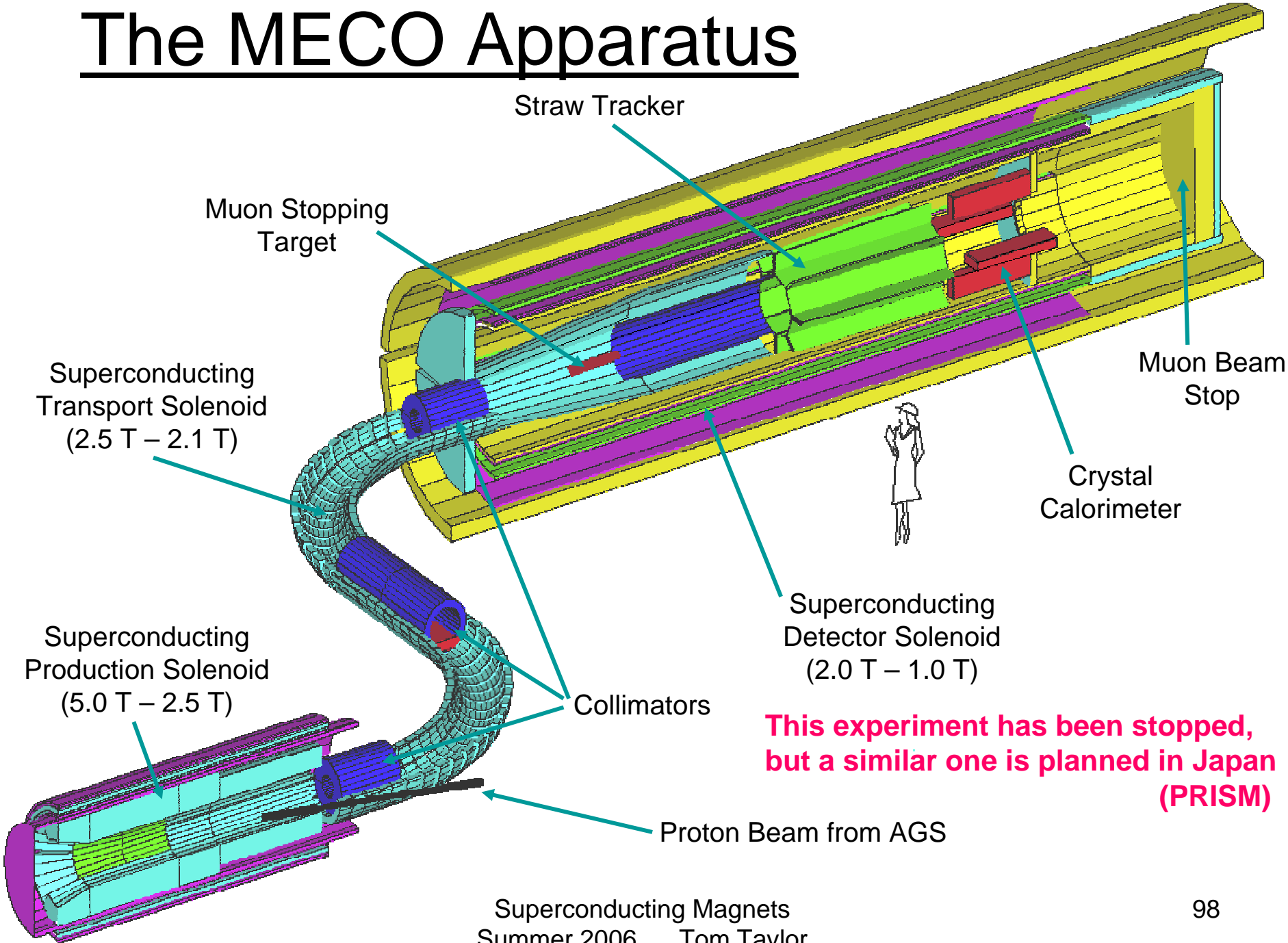

This experiment has been stopped, but a similar one is planned in Japan (PRISM)

So what next ?

- **New initiatives will need higher fields
- or radically different (cheaper) magnets**
- **We have probably gone as far as we can with Nb-Ti. We need to use other conductors – but they are all brittle – this is a big challenge**
- **Work is being done, but funding is scarce ...**

Low Temperature Superconductors (LTS)

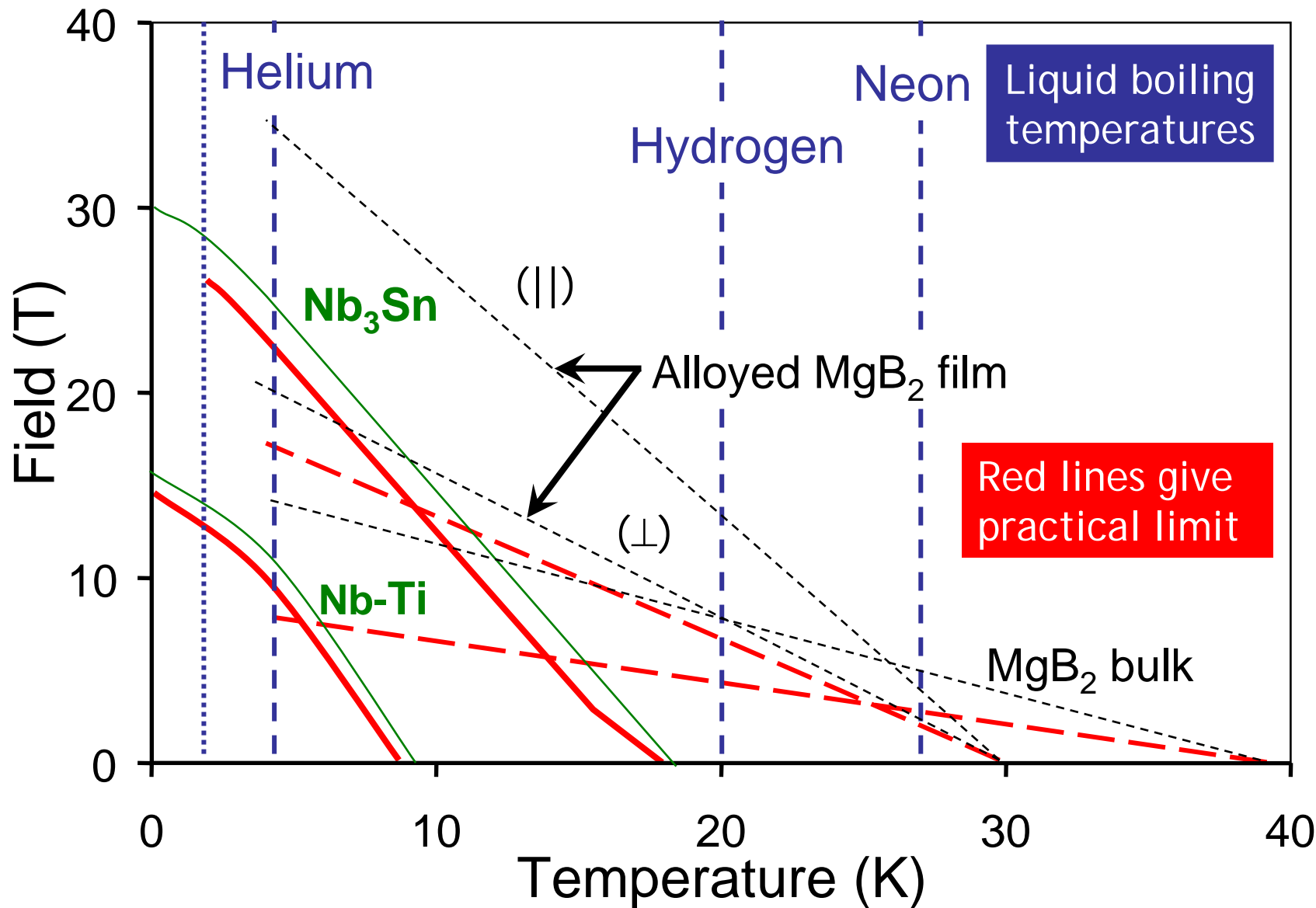

What's after LHC ?

Luminosity upgrade

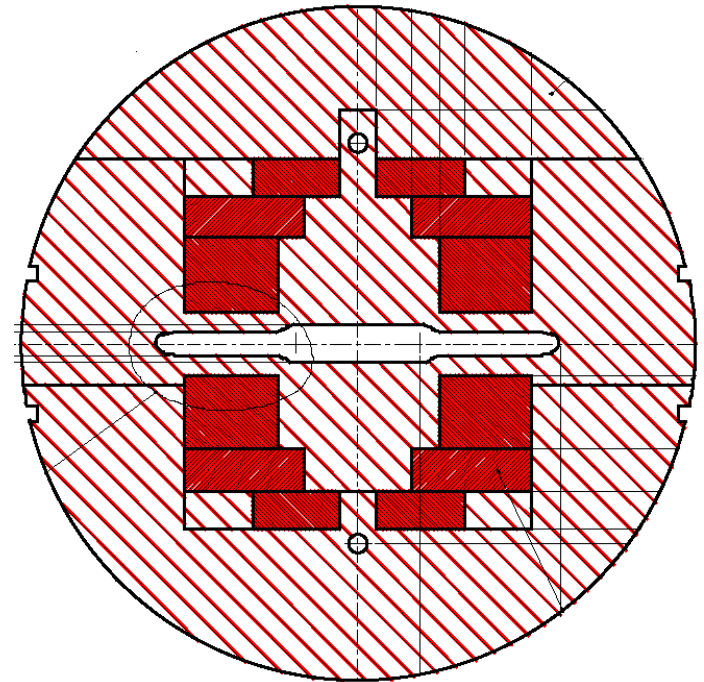
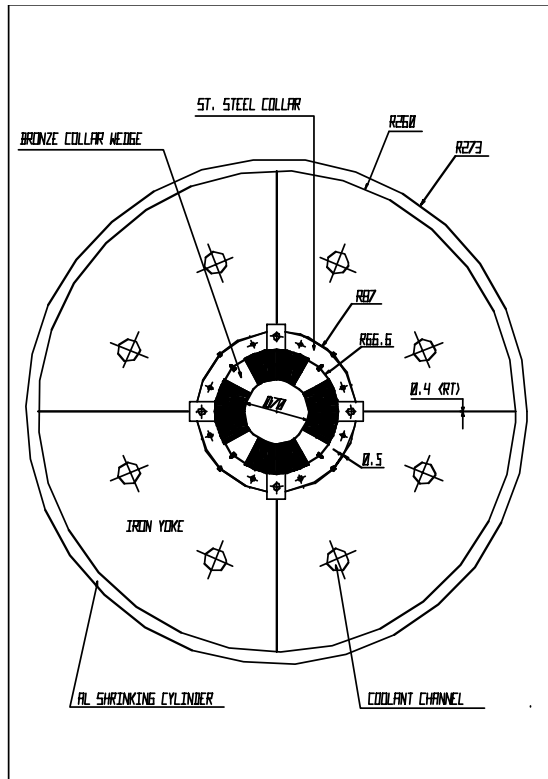

LTS and High Temperature SC (HTS)

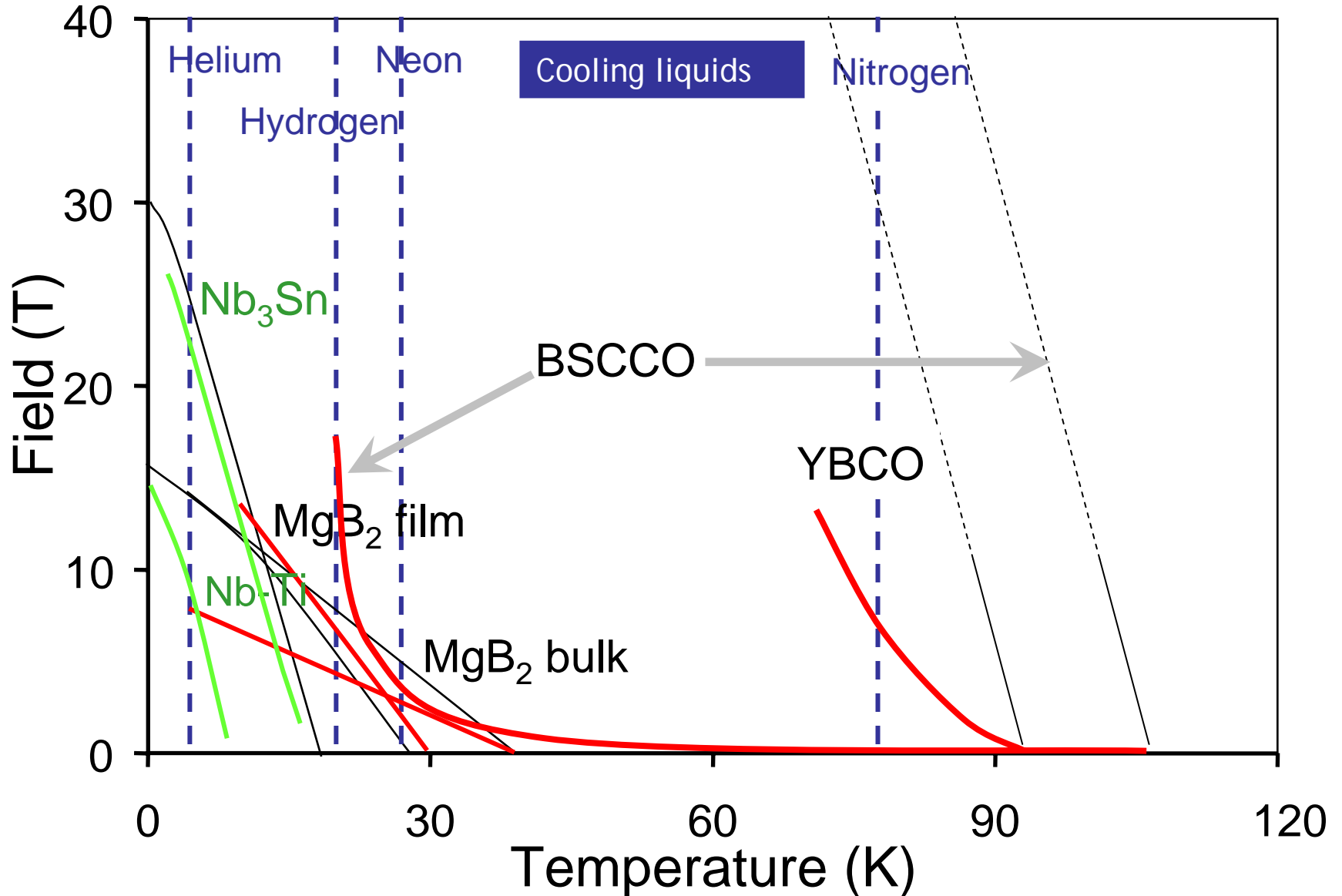

HTS in the LHC machine

Powering of the LHC magnets

About 3 MA of rated current for 1800 circuits

3286 current leads

Quantity	Current rating (A)
64	13000
298	6000
820	600
2104	60-120

HTS

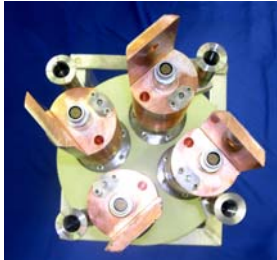

And then ? After 2015 ? Why not an energy upgrade for LHC !

With a new type of magnet

?



Or a future in outer space?

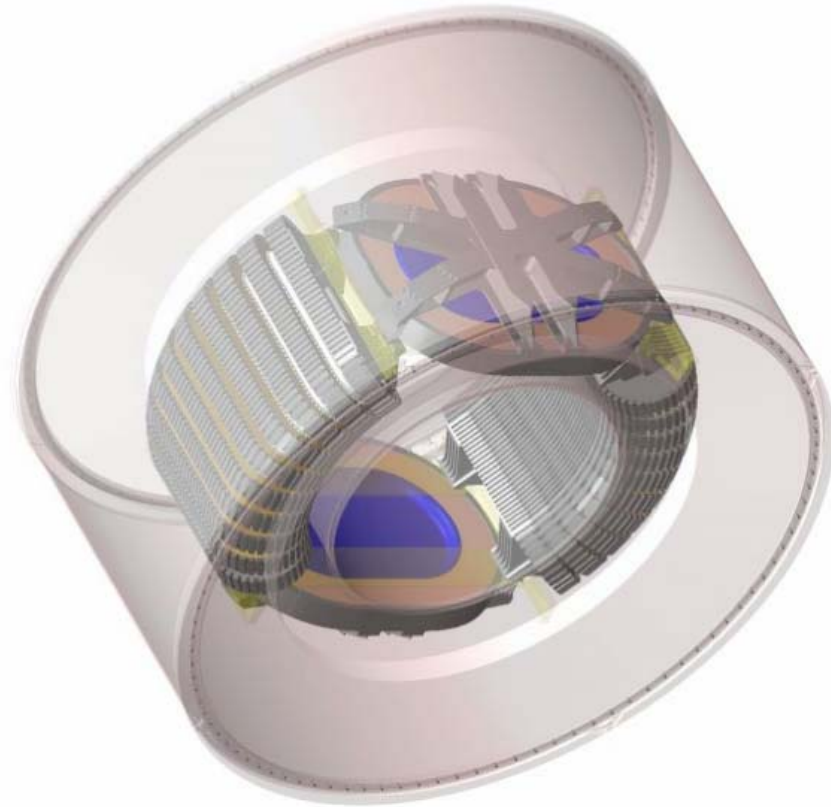
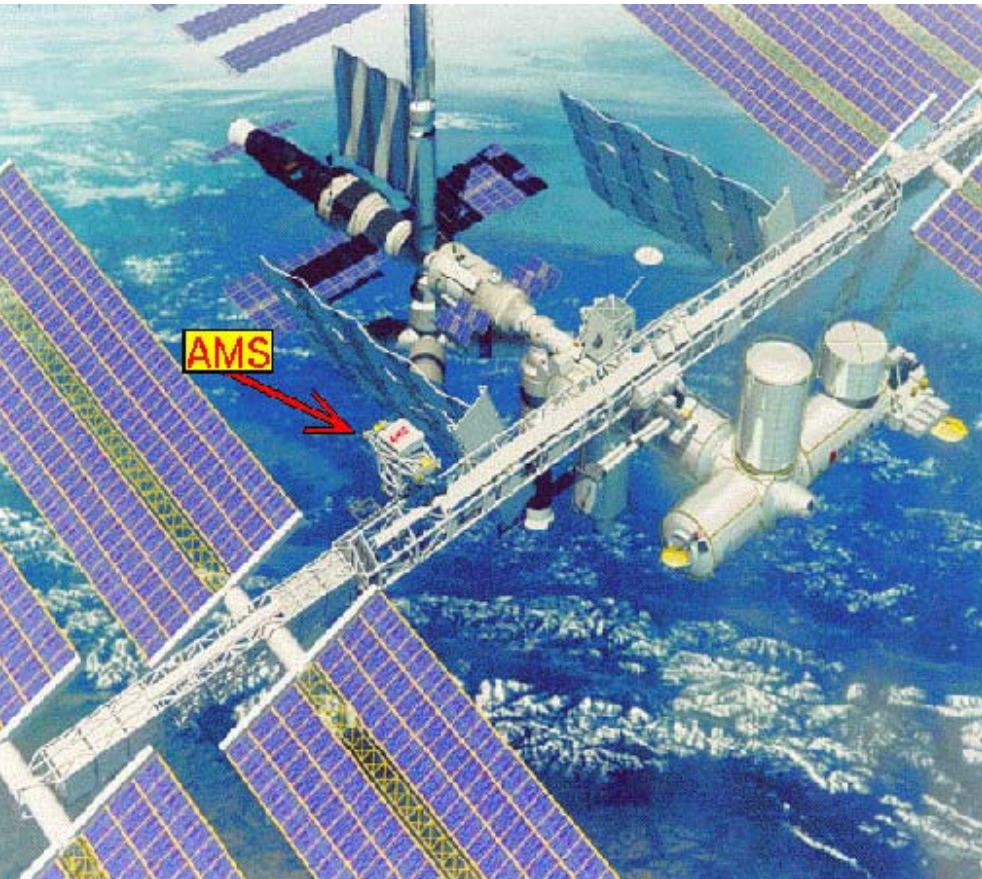

Technology: can
be beautiful if
well done !

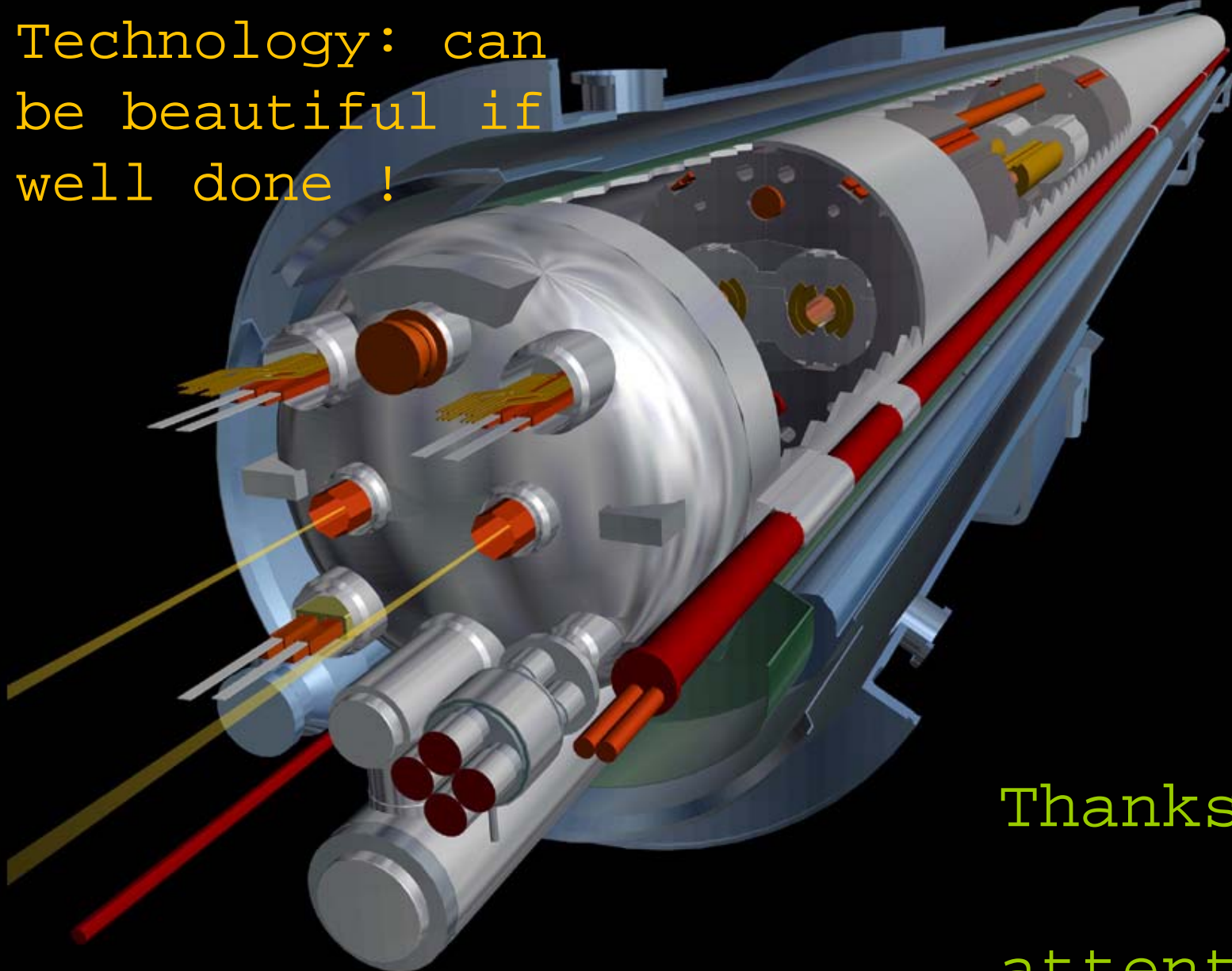

Thanks for
the
attention!